

100Gb/s QSFP Optical Transceiver Module

SQF1002L4LNGG01P

(100GBASE-LR4, 1300nm 4-lane LAN WDM, DFB-LD, PIN-PD)

Features

- ◆ 4-lane x 25Gb/s LAN WDM Optical Interface
 - High quality and reliability optical sub-assemblies
 - 1300nm range Cooled DFB-LD Transmitter with optical MUX
 - High Sensitivity PIN-TIA with optical DEMUX
 - 1300nm band with 800GHz spacing LAN WDM grid up to 10km over a SMF
- ◆ IEEE802.3 Compliant
 - IEEE802.3 Clause 88 100GBASE-LR4
 - CAUI-4(4x25G) Electrical Interface
 - 2 Wire Serial Interface for module management
- ◆ QSFP28 MSA Compliant
 - Easy supply management for hot pluggability
 - QSFP28 MSA Form Factor
 - 38pin Electrical Connector
 - Dual LC Receptacle
 - Pull Tab and Bail Latch(Optional) is available
- ◆ Low Power Consumption
 - 3.3V single power supply
 - Power consumption less than 4.0W
- ◆ RoHS Compliant



Applications

- interconnects between switches connection
- Routers and transport equipment connection
- Proprietary High-speed interconnects

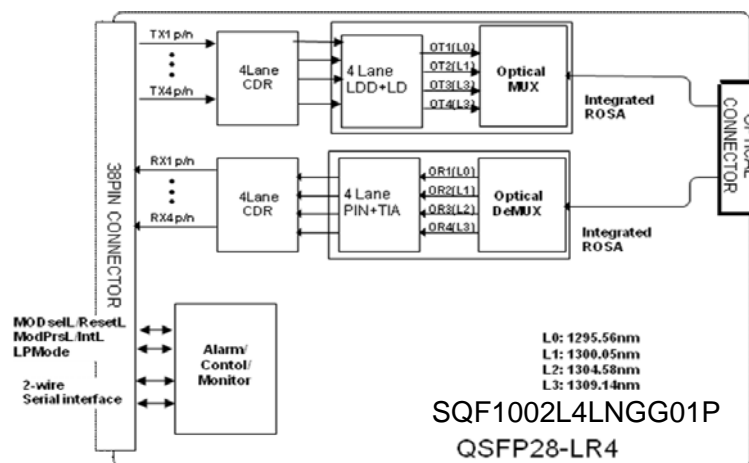

Figure 1.1.: Block Diagram