

■ Features

- High Output Power: P1dB=36.0dBm (Typ.)
- High Gain: G1dB=10.5dB (Typ.)
- High Power Added Efficiency: PAE=35% (Typ.)
- Broad Band: Frequency=7.1 to 7.9GHz
- Internally Matched
- Plastic Package for SMT applications

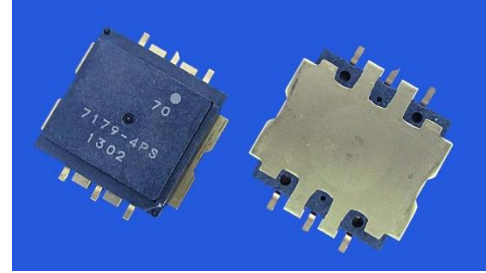

■ Description

The ELM7179-4PS is a power GaAs FET that is internally matched for standard communication bands to provide optimum power and gain.

ABSOLUTE MAXIMUM RATING (Case Temperature $T_c=25$ deg.C)

Item	Symbol	Rating	Unit
Drain-Source Voltage	V_{DS}	15	V
Gate-Source Voltage	V_{GS}	-5	V
Total Power Dissipation	P_T	27.3	W
Storage Temperature	T_{stg}	-40 to +125	deg.C
Channel Temperature	T_{ch}	175	deg.C

RECOMMENDED OPERATING CONDITION

Item	Symbol	Condition	Limit	Unit
Drain-Source Voltage	V_{DS}		<10	V
Forward Gate Current	I_{GF}	Rg=100ohm	<+16	mA
Reverse Gate Current	I_{GR}	Rg=100ohm	> -2.2	mA
Channel Temperature	T_{ch}		155	deg.C

ELECTRICAL CHARACTERISTICS (Case Temperature $T_c=25$ deg.C)

Item	Symbol	Condition	Limit			Unit
			Min.	Typ.	Max.	
Saturated Drain Current	I_{DSS}	$V_{DS}=5V, V_{GS}=0V$	-	1700	2600	mA
Trans Conductance	g_m	$V_{DS}=5V, I_{DS}=1100mA$	-	1700	-	mS
Pinch-off Voltage	V_P	$V_{DS}=5V, I_{DS}=85mA$	-0.5	-1.5	-3.0	V
Gate-Source Breakdown Voltage	V_{GSO}	$I_{GS}=-85uA$	-5.0	-	-	V
Output Power at 1dB G.C.P.	P_{1dB}	$V_{DS}=10V$ $I_{DS}(DC)=1100mA(typ.)$ $f=7.1$ to 7.9 GHz	35.0	36.0	-	dBm
Power Gain at 1dB G.C.P.	G_{1dB}		9.5	10.5	-	dB
Drain Current	I_{DSR}		-	1100	1300	mA
Power Added Efficiency	PAE		-	35.0	-	%
Gain Flatness	ΔG		-	-	1.2	dB
3rd Order Inter Modulation Distortion	IM_3	$f=7.9GHz$ $\Delta f=10MHz, 2-tone$ Test $P_{out}=25.5dBm$ (S.C.L.)	-40.0	-43.0	-	dBc
Thermal Resistance	R_{th}	Channel to Case	-	4.5	5.5	deg.C/W
Channel Temperature Rise	ΔT_{ch}	$(V_{DS} \times I_{DSR} - P_{out} + P_{in}) \times R_{th}$	-	-	71.5	deg.C

G.C.P. : Gain Compression Point, S.C.L. : Single Carrier Level

CASE STYLE	I2C
RoHS Compliance	YES
ESD	Class 3A
MSL	2
	4000V to < 8000V
	One year after opening the packing

Note : Based on ANSI/ESDA/JEDEC JS-001-2012(C=100pF, R=1.5kohm)

Ordering Information

Model Type	MOQ	MOU	Packing Style
ELM7179-4PS	15pcs	15pcs	50pcs-max./Tray , 1Tray-max./Packing
ELM7179-4PST	500pcs	500pcs	24mm width Tape (500pcs/Reel)

* MOQ stands for Minimum Order Quantity.

* MOU stands for Minimum Order Unit size.

Note

- This device will not be delivered with test data but tested pass/fail 100% against DC and RF specifications.
- NO liquid cleaning process is suitable for this device. (including de-ionized water or solvent)

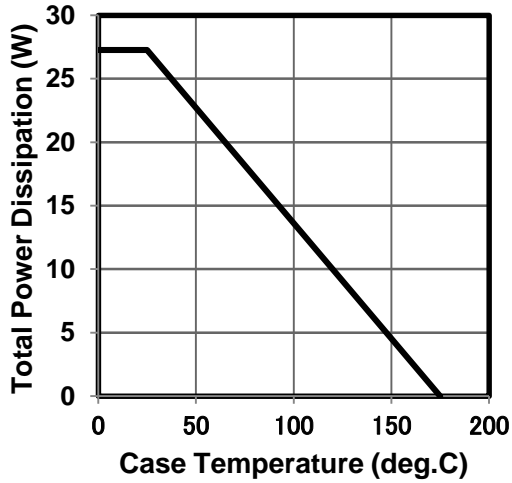
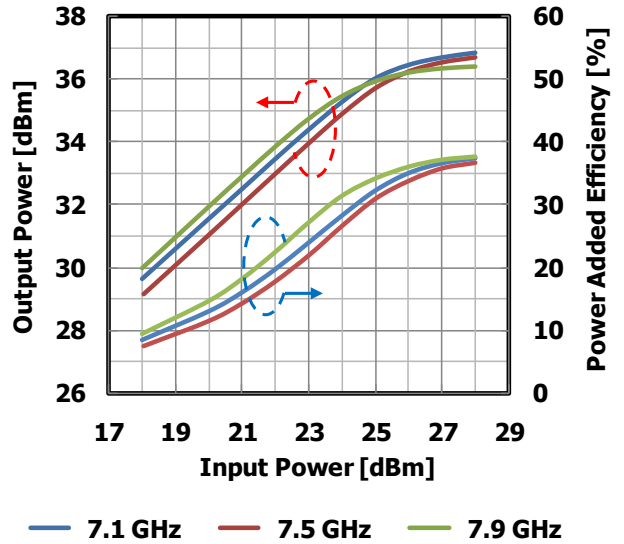
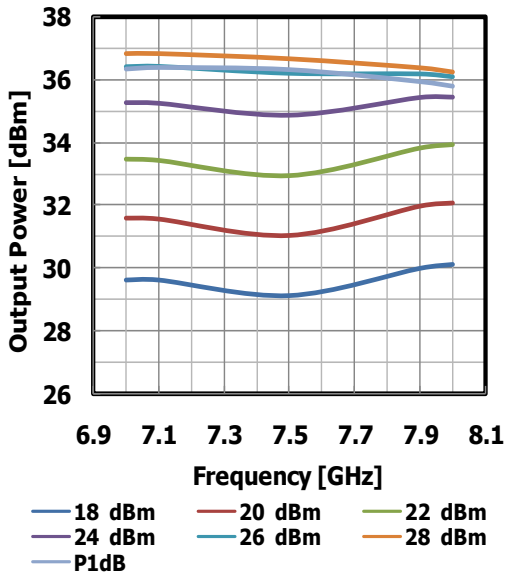
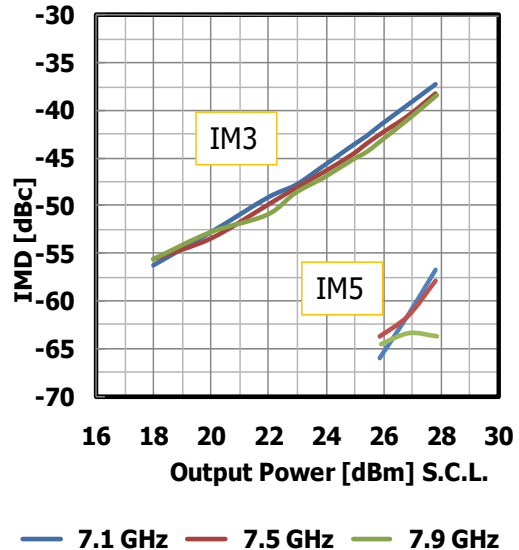
RF Characteristics
Power Derating Curve

Input Power vs. Output Power and Power Added Efficiency
 $V_{DS}=10V, I_{DS(DC)}=1100mA$

Output Power vs. Frequency
 $V_{DS}=10V, I_{DS(DC)}=1100mA$

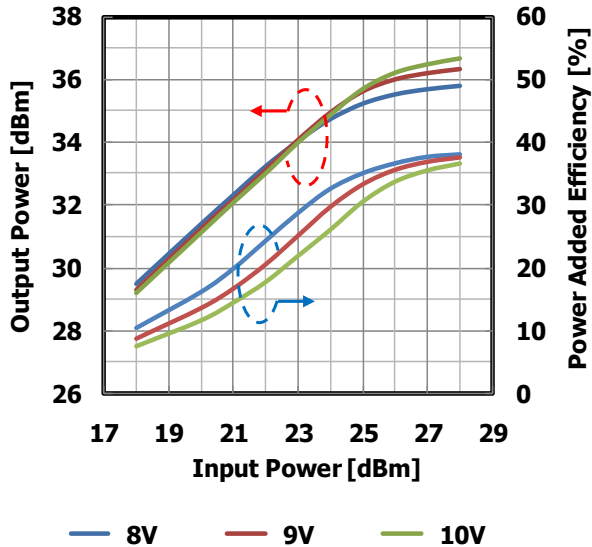
IMD vs. Output Power
 $V_{DS}=10V, I_{DS(DC)}=1100mA$

● RF Characteristics

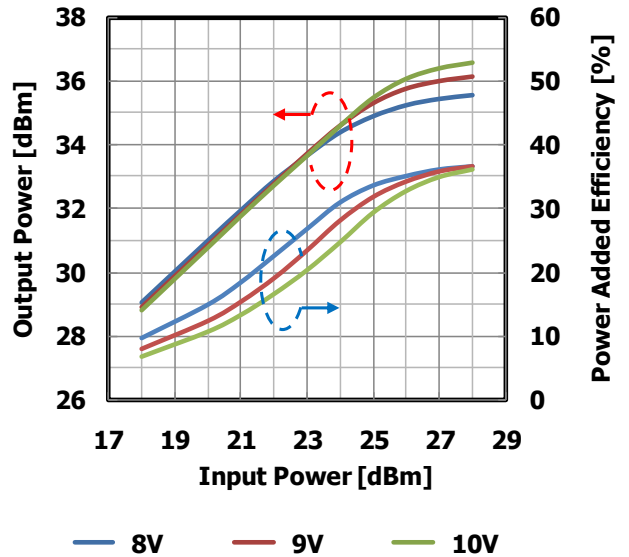
Input Power vs. Output Power, Power Added Efficiency by Drain Voltage
IDS(DC)=1100mA @7.1GHz



Input Power vs. Output Power, Power Added Efficiency by Drain Voltage
IDS(DC)=1100mA @7.5GHz



Input Power vs. Output Power, Power Added Efficiency by Drain Voltage
IDS(DC)=1100mA @7.9GHz

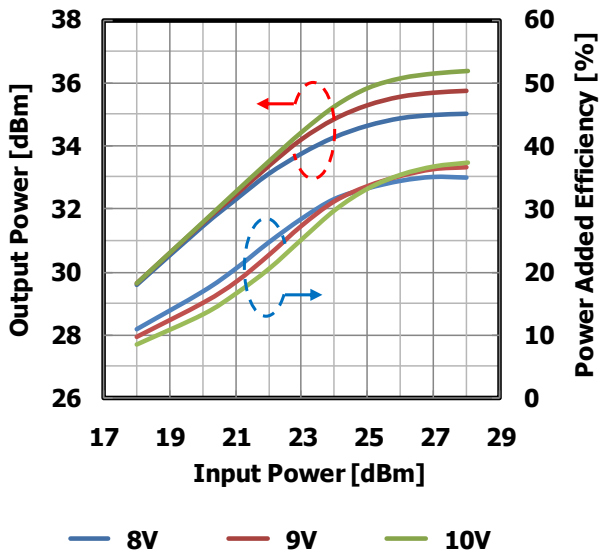

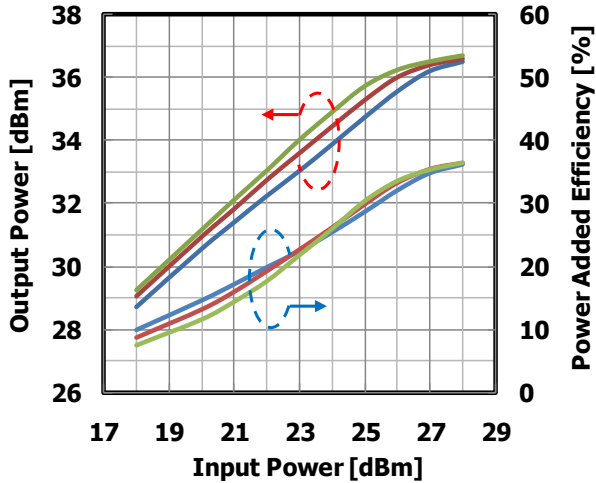
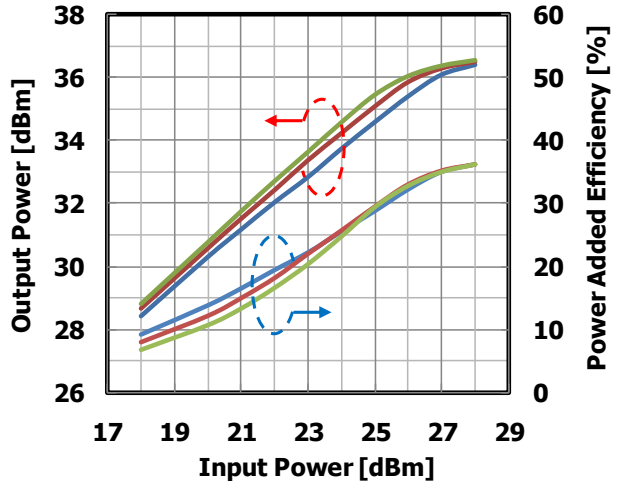
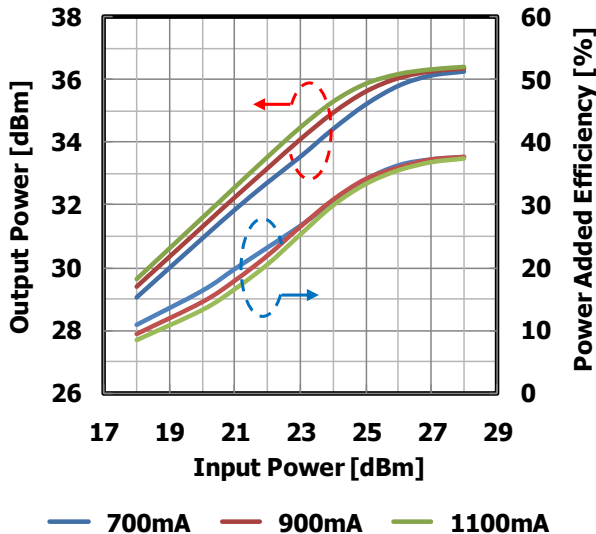
● RF Characteristics
**Input Power vs. Output Power, Power Added Efficiency by Quiescent Drain Current
VDS=10V @7.1GHz**

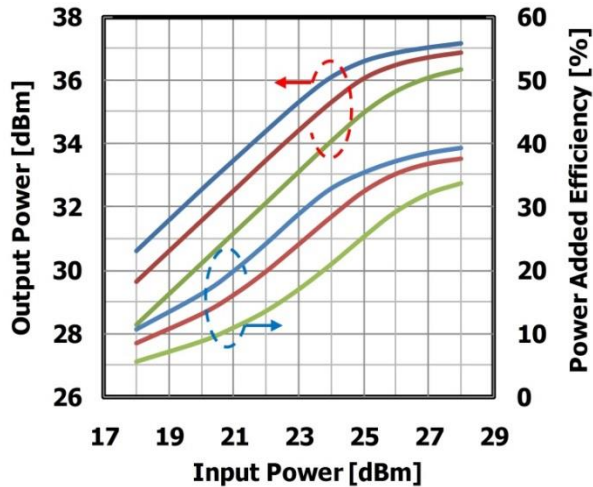
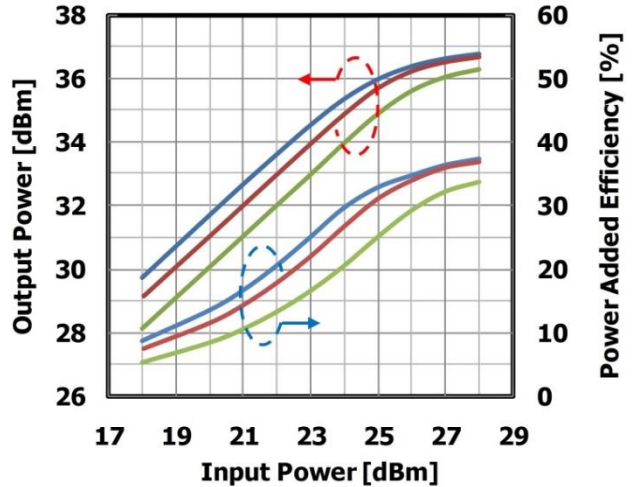
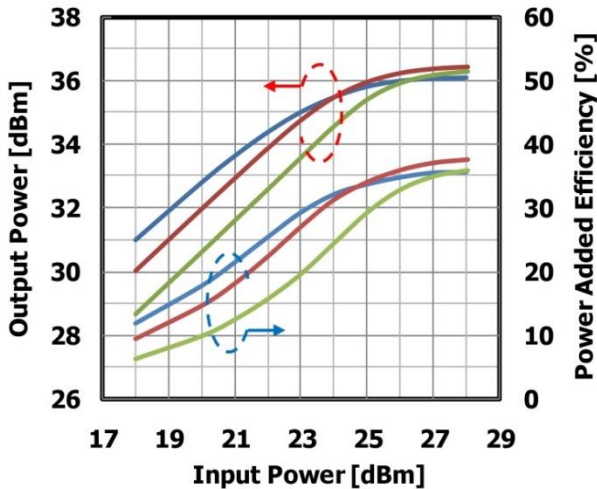
**Input Power vs. Output Power, Power Added Efficiency by Quiescent Drain Current
VDS=10V @7.5GHz**

**Input Power vs. Output Power, Power Added Efficiency by Quiescent Drain Current
VDS=10V @7.9GHz**

● RF Characteristics
Input Power vs. Output Power, Power Added Efficiency by Temperature
VDS=10V @7.1GHz

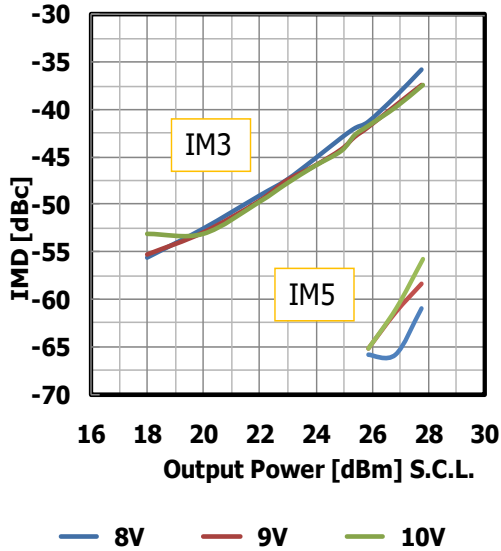
Input Power vs. Output Power, Power Added Efficiency by Temperature
VDS=10V @7.5GHz

Input Power vs. Output Power, Power Added Efficiency by Temperature
VDS=10V @7.9GHz

● RF Characteristics

**IMD Performance vs. Output Power
by Drain Voltage**
 IDS(DC)=1100mA @7.1GHz

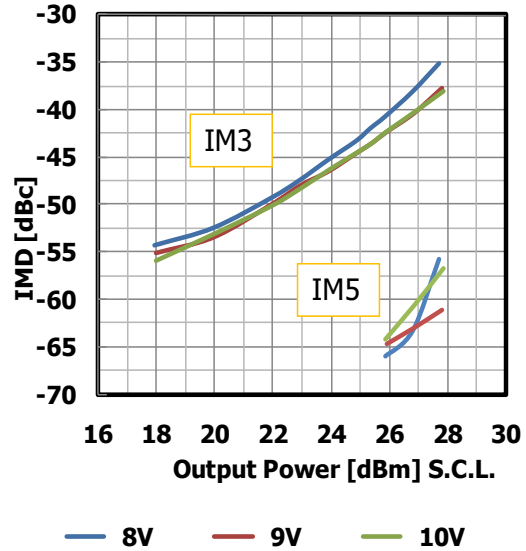

**IMD Performance vs. Output Power
by Drain Voltage**
 IDS(DC)=1100mA @7.5GHz



**IMD Performance vs. Output Power
by Drain Voltage**
 IDS(DC)=1100mA @7.9GHz

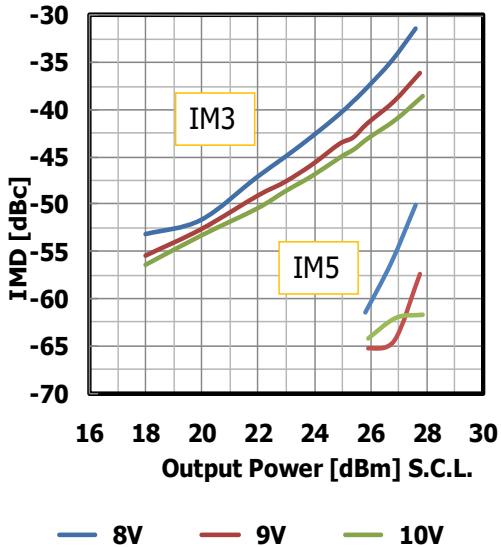

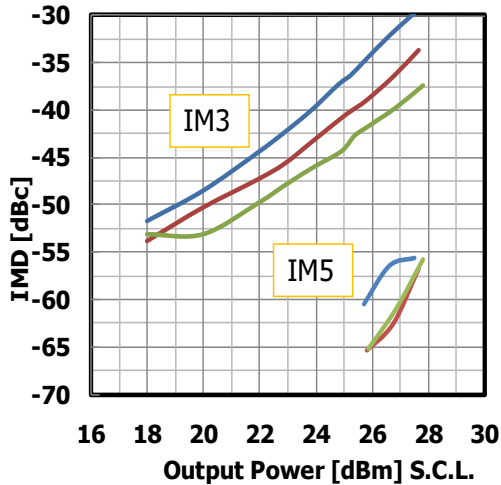
● RF Characteristics
**IMD Performance vs. Output Power
by Quiescent Drain Current
VDS=10V @7.1GHz**

— 700mA — 900mA — 1100mA

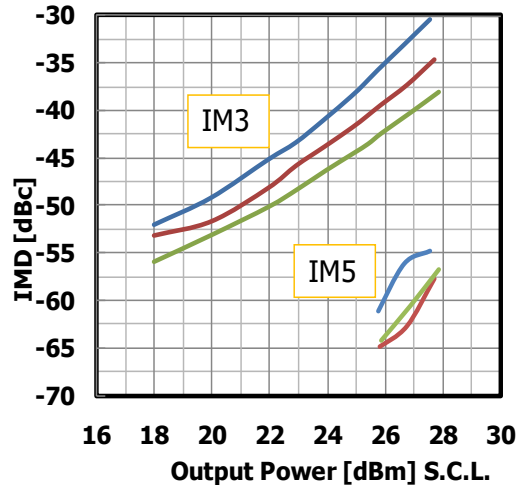
**IMD Performance vs. Output Power
by Quiescent Drain Current
VDS=10V @7.5GHz**

— 700mA — 900mA — 1100mA

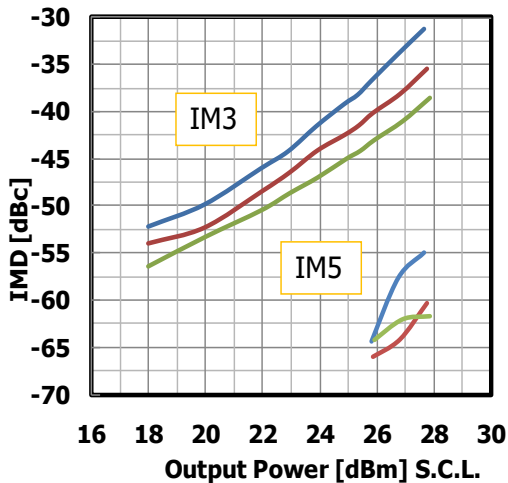
**IMD Performance vs. Output Power
by Quiescent Drain Current
VDS=10V @7.9GHz**

— 700mA — 900mA — 1100mA

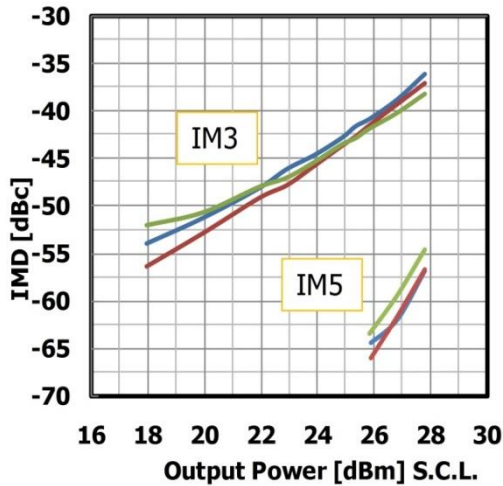
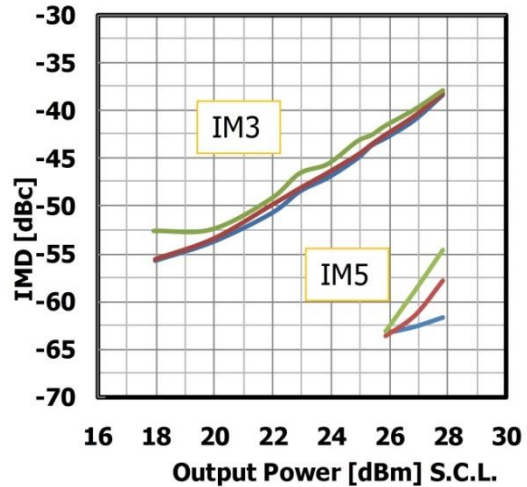
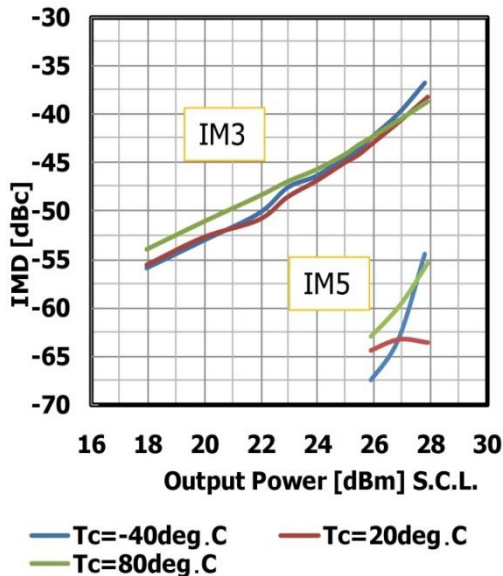
● RF Characteristics
**IMD Performance vs. Output Power
by Temperature**
VDS=10V @7.1GHz

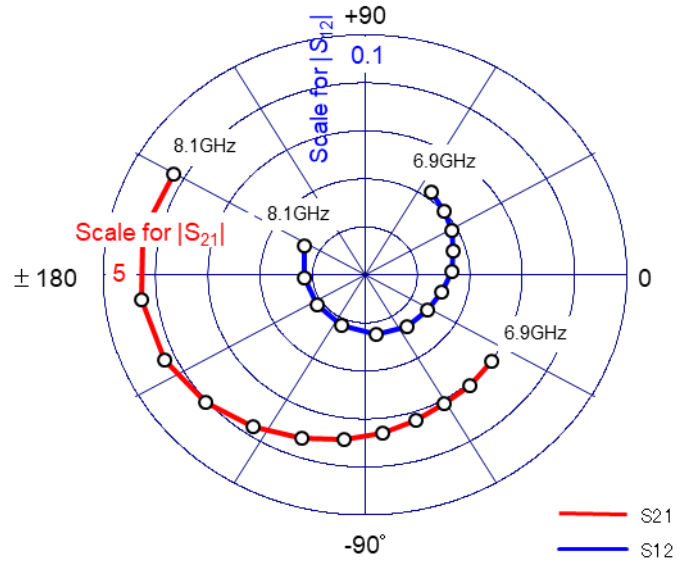
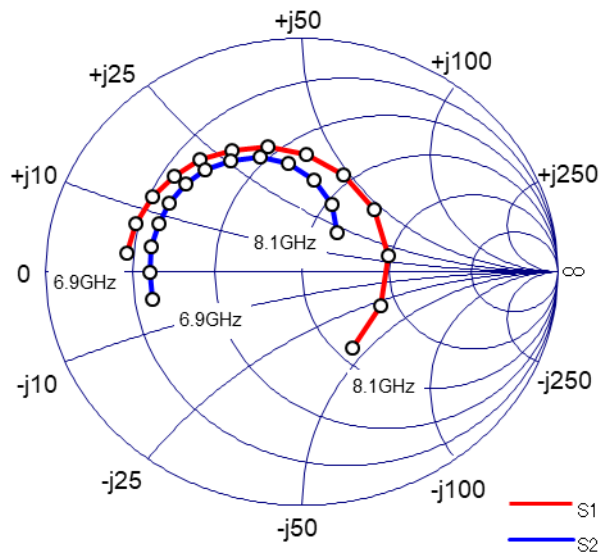
**IMD Performance vs. Output Power
by Temperature**
VDS=10V @7.5GHz

**IMD Performance vs. Output Power
by Temperature**
VDS=10V @7.9GHz

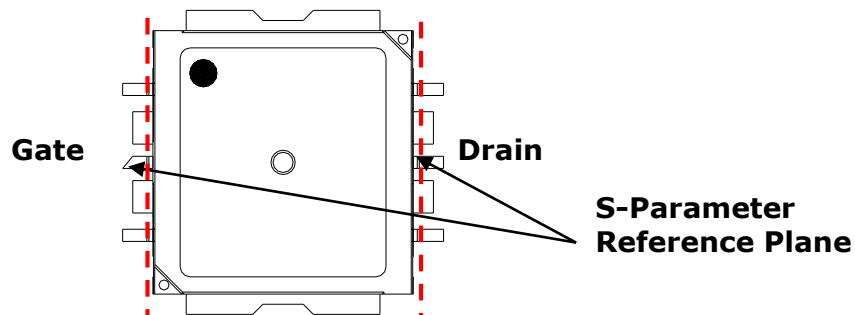

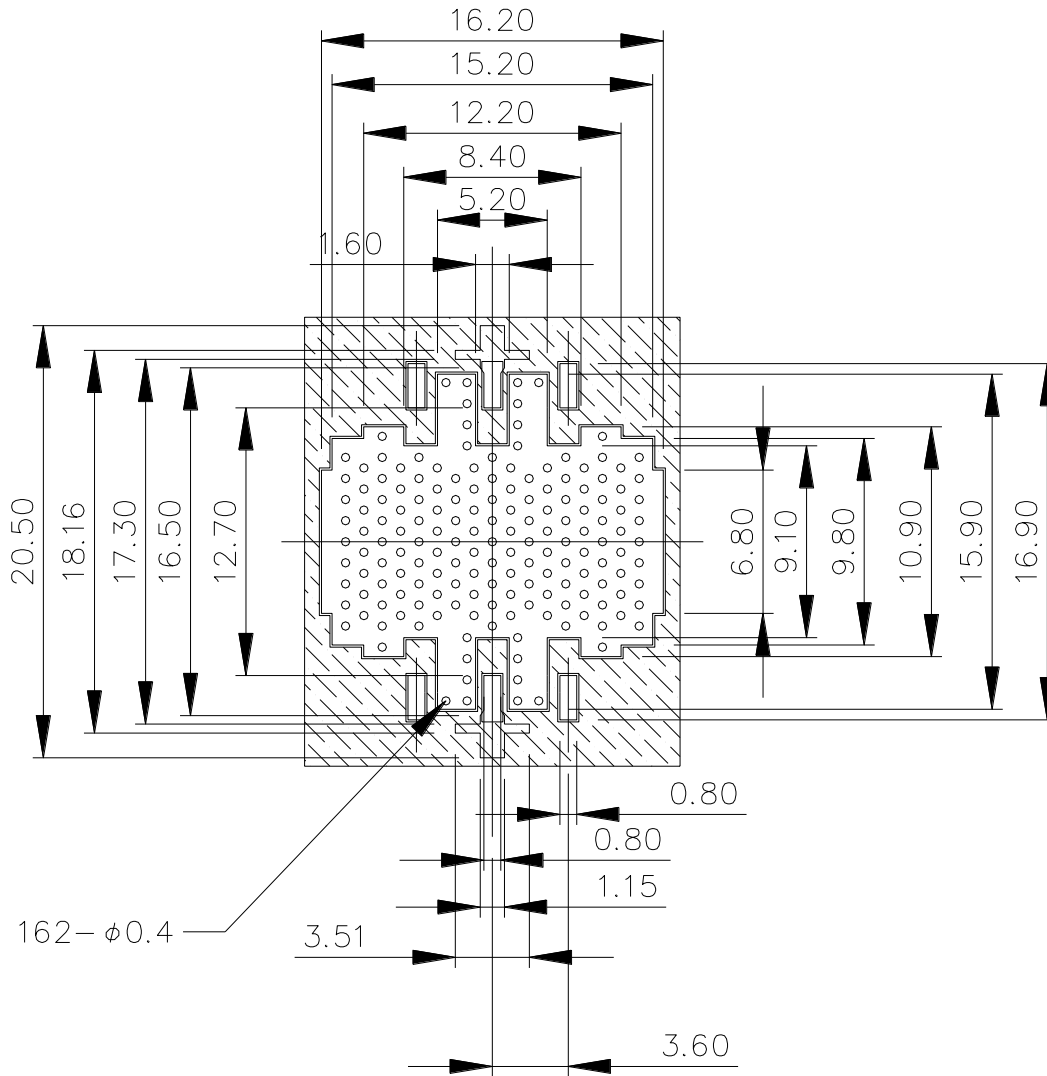
● S-Parameter

Frequency (MHz)	S11		S21		S12		S22	
	MAG	ANG	MAG	ANG	MAG	ANG	MAG	ANG
6900	0.689	173.1	3.012	-36.9	0.043	54.0	0.593	-168.4
7000	0.678	162.1	3.041	-49.1	0.040	41.5	0.592	179.9
7100	0.662	151.1	3.081	-60.8	0.038	29.3	0.597	169.4
7200	0.644	140.3	3.176	-72.3	0.035	16.3	0.597	159.5
7300	0.621	129.4	3.316	-84.2	0.033	2.5	0.596	150.1
7400	0.589	117.5	3.448	-96.5	0.030	-13.4	0.589	140.3
7500	0.552	104.0	3.614	-109.7	0.028	-31.1	0.575	130.7
7600	0.506	87.9	3.820	-123.9	0.027	-53.2	0.553	120.0
7700	0.450	68.4	4.038	-139.0	0.025	-80.7	0.519	108.4
7800	0.389	43.5	4.204	-155.2	0.023	-112.7	0.466	96.6
7900	0.344	11.5	4.311	-173.0	0.022	-145.5	0.398	83.2
8000	0.341	-24.7	4.336	168.5	0.023	-177.0	0.314	67.5
8100	0.380	-58.8	4.212	149.9	0.026	152.6	0.217	50.4



● PCB Pads and Solder-Resist Pattern

Notes :

1. Laminate : Rogers Corporation R04003, Thickness $t=0.508\text{mm}$, Cu Foil $18\mu\text{m}$.
 Finish to copper foil : Ni $0.1\mu\text{m}$ min. / Au $0.1\mu\text{m}$ (Both side).
2.  : Resist

- **JEDEC Tray Dimension
(Part No:ELM7179-4PS)**

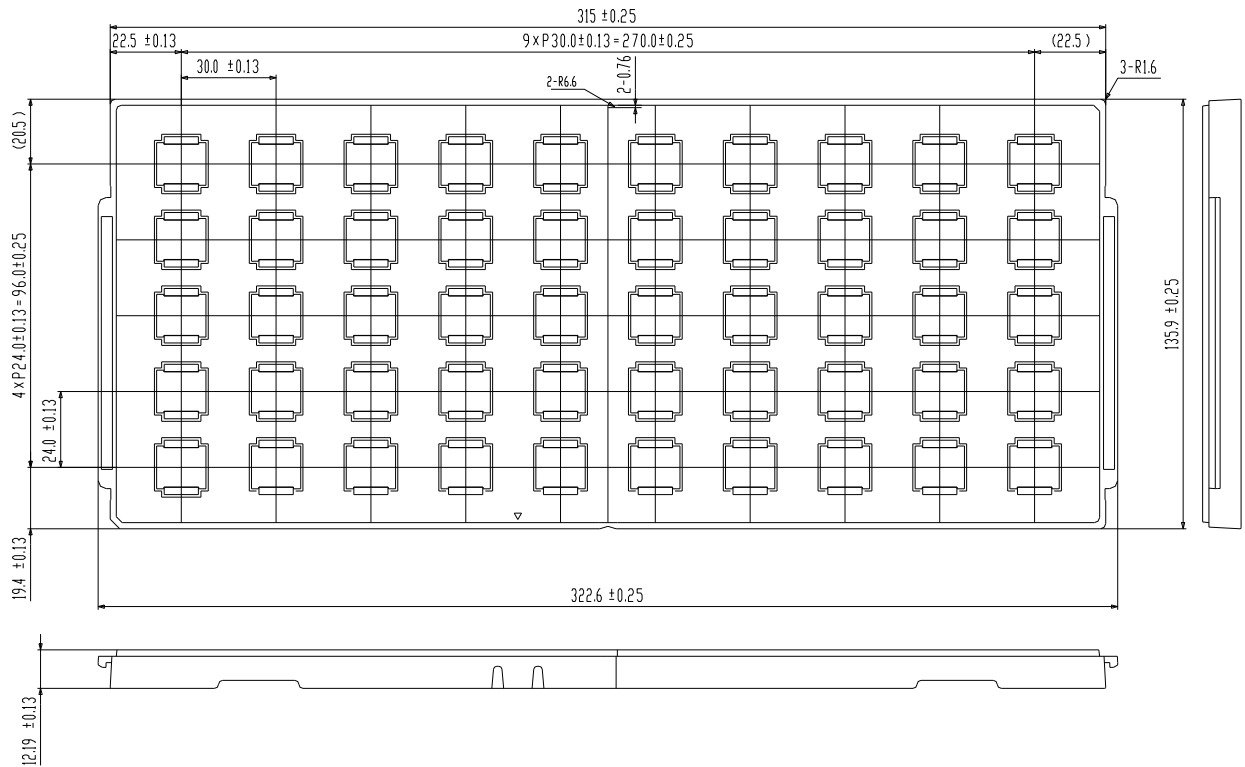

● **Tape/Reel Configuration**
(Part No:ELM7179-4PST)

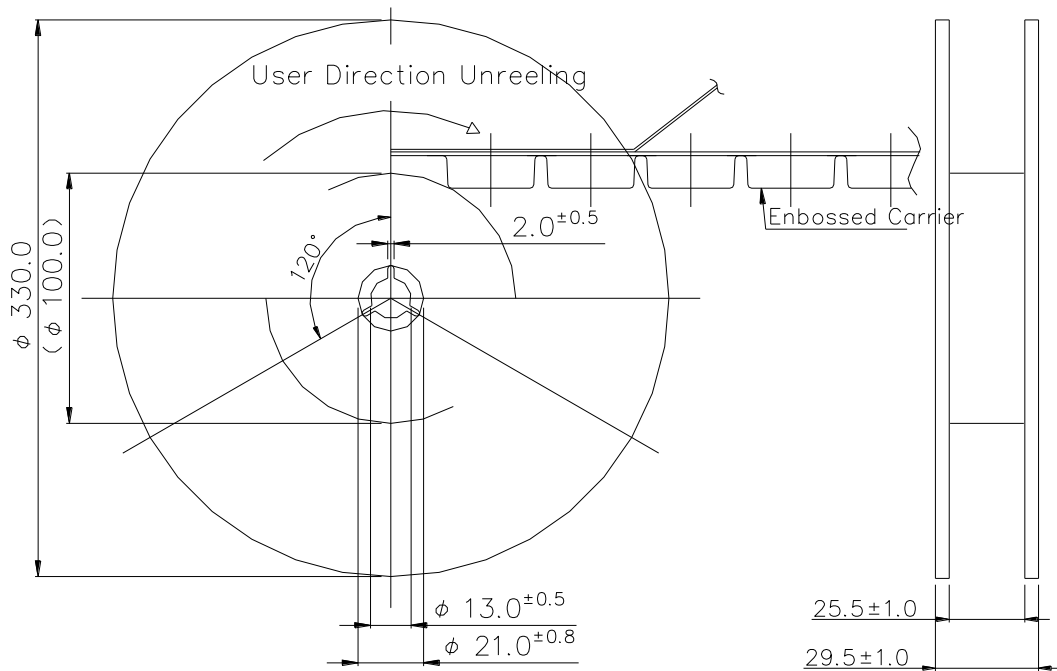
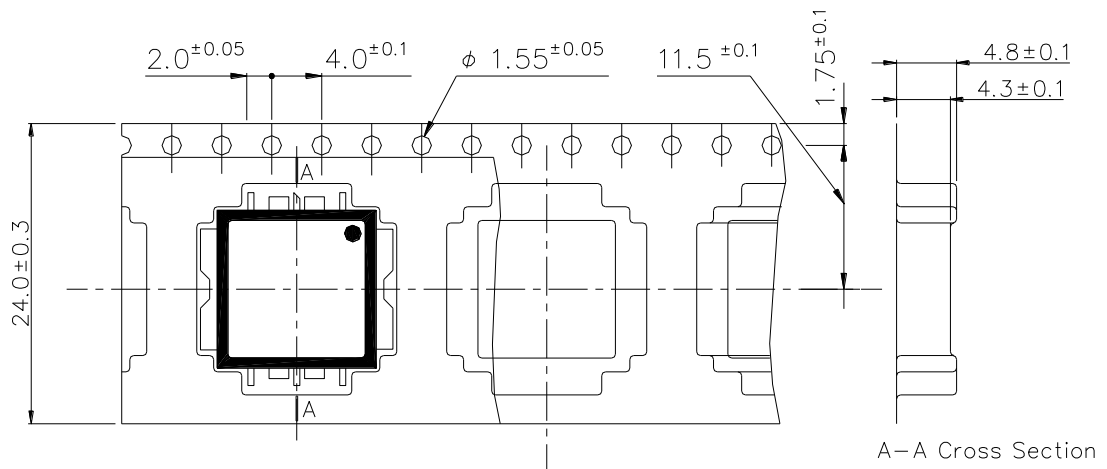

Quantity: 500pcs/tape
Tape Material: Conductive PS

(unit in mm)

● Mounting Instructions for Package for Lead-free solder

Mounting Condition

For soldering, Lead-free solder (Sn-3.0Ag-0.5Cu)*1 or equivalent shall be used.

1. The example solder is a tin-rich alloy with 3.0% silver and 0.5% copper, often called Sn 96 for its approximate Tin content.
2. A rosin type flux with chlorine content of 0.2% or less shall be used. The rosin flux with low halogen content is recommended. When soldering, use the following time/ temperature profile with any of the methods listed for acceptable solder joints.
3. Make sure the devices have been properly prepared with flux prior soldering.

* Reflow soldering method (Infrared reflow / Heat circulation reflow / Hot plate reflow);

Limit solder to 3 reflow cycles because resin is used in the modules manufacturing process.

Excessive reflow will effect the resin resulting in a potential failure or latent defect.

The recommended reflow temperature profile is shown below. The temperature of the reflow profile must be measured at the device lead.

● Reflow temperature profile and condition:

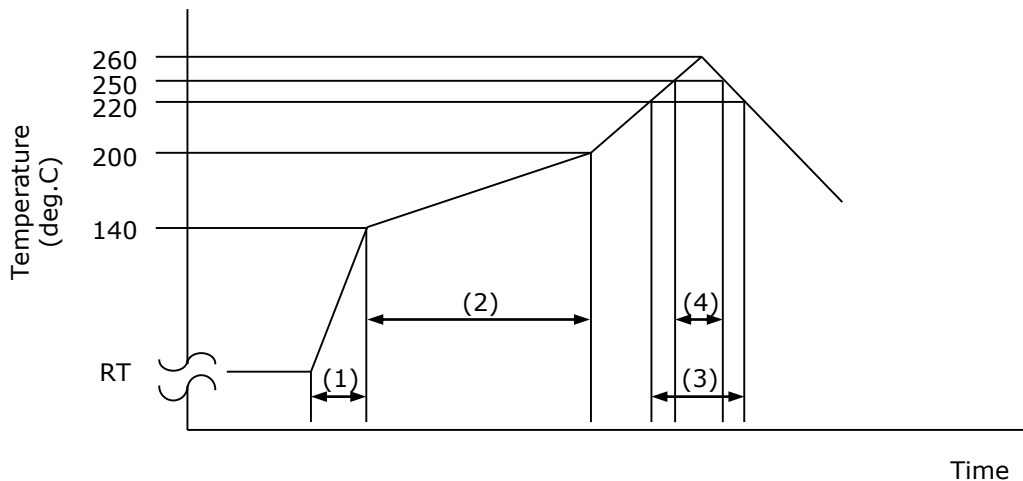

- (1). Temperature rise: 3 deg.C/seconds.
 - (2). Preheating: 150 to 200 deg.C, 60 to 180seconds.
 - (3). Main heating: 220 deg.C, 60 seconds max.
 - (4). Main heating: 260 deg.C max., more than 250 deg.C, 20 to 40 seconds max.
- * Measurement point: Device Heat-sink (Source Pin).

1. The above-recommended conditions were confirmed using the manufacturer's equipment and materials. However, when soldering these products, the soldering condition should be verified by customer using their own particular equipment and materials.

● Cleaning

Avoid washing of the device after soldering by reflow method due to the risk of liquid absorption by the resin used in this part.

● Humidity Lifetime and fit rate for ELMxxxx-4PST

The following graph shows the effect of moisture on lifetime (moisture resistance) for the ELMxxxx-4PST. Each graph indicates the MTTF and failure rate prediction (Confidential Level = 90 %) which calculated from the results of highly accelerated temperature and humidity stress test (HAST).

Representative of device type : ELM7179-4PST

Subject of device type : ELMxxxx-4PST

Field environmental conditions for operation

If the **ELMxxxx-4PST** is installed in a non-hermetic environment, please refer to the following recommendations and notes for design with, and assembly and use of our products.

- Note 1. When drain current cuts off, it should be cut off by drain bias, and not cut off by gate bias only. The humidity lifetime becomes shorter in case of the gate-only cut off operation due to electric field strength interacting with humidity.
- Note 2. **ELMxxxx-4PST** should be used under the environment conditions of no dew condensation. These plots do not apply in the case of liquid absorbed into the resin, whether applied to the part in assembly or as condensate in the application.

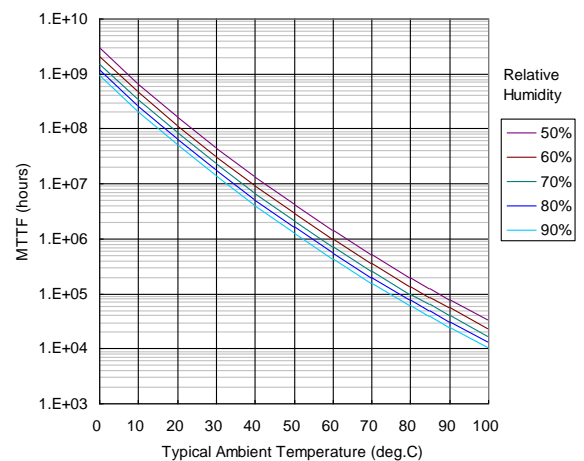
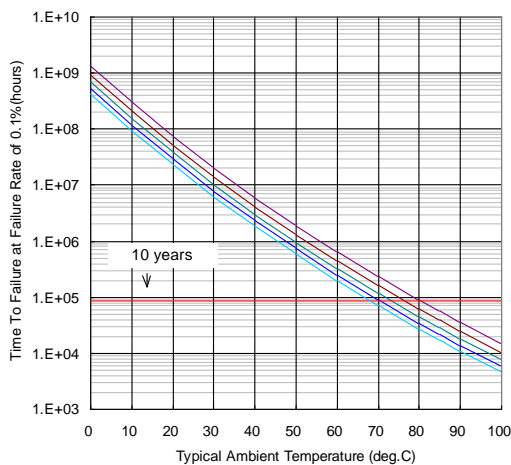

For Safety, Observe the Following Procedures Environmental Management

- Do not put this product into the mouth.
- Do not alter the form of this product into a gas, powder, or liquid through burning, crushing, or chemical processing as these by-products are dangerous to the human body if inhaled, ingested, or swallowed.
- Respect all applicable laws of the country when discarding this product.
This product must be disposed in accordance with methods specified by applicable hazardous waste procedures.

Any information, such as descriptions of a function and examples of application circuits, in this document are presented solely as a reference for the purpose to show examples of operations and uses of Sumitomo Electric semiconductor device(s); Sumitomo Electric does not warrant the proper operation of the device(s) with respect to its use based on such information. When the user develops equipment incorporating the device(s) based on such information, they must assume full responsibility arising out of using such information. Sumitomo Electric assumes no liability for any damages whatsoever arising out of the use of the information.

Any information in this document, including descriptions of function and schematic diagrams, shall not be construed as a license for the use or exercise of any intellectual property right, such as patent right or copyright, or any other right of Sumitomo Electric or any third party nor does Sumitomo Electric warrant non-infringement of any third-party's intellectual property right or other right by using such information. Sumitomo Electric assumes no liability for any infringement of the intellectual property rights or other rights of third parties which would result from the use of information contained herein.

The products described in this document are designed, developed and manufactured as contemplated for general use, including, without limitation, ordinary industrial use, general office use, personal use, and household use, but are not designed, developed and manufactured as contemplated (1) for use accompanying fatal risks or dangers that, unless extremely high safety is secured, could have a serious effect to the public, and could lead directly to death, personal injury, severe physical damage or other loss (i.e., nuclear reaction control in nuclear facility, aircraft flight control, air traffic control, mass transport control, medical life support system, missile launch control in weapon system), or (2) for use requiring extremely high reliability (i.e., submersible repeater and artificial satellite). Please note that Sumitomo Electric will not be liable to the user and/or any third party for any claims or damages arising from the aforementioned uses of the products.

Any semiconductor devices have an inherent chance of failure. You must protect against injury, damage or loss from such failures by incorporating safety design measures into your facility and equipment such as redundancy, fire protection, and prevention of excessive current levels and other abnormal operating conditions.

If any products described in this document represent goods or technologies subject to certain restrictions on export under the Foreign Exchange and Foreign Trade Law of Japan, the prior authorization of the Japanese government will be required for export of those products from Japan.

<http://www.sedi.co.jp/>

ATTENTION

Information in this document is subject to change without notice.