

具有 ECO-Mode™ 的 4.5V 至 18V 输入，6.5A 同步降压 SWIFT™ 转换器

 查询样品: [TPS54626](#)

特性

- **D-CAP2™** 模式支持快速瞬态响应
- 低输出纹波，支持陶瓷输出电容器
- 宽 **VIN** 输入电压范围：**4.5V 至 18V**
- 输出电压范围：**0.76V 至 5.5V**
- 高效率集成型场效应晶体管 (**FET**) 针对更低占空比应用进行了优化 — **36mΩ** (高侧) 与 **28 mΩ** (低侧)
- 关断时的高效率，流耗不足 **10μA**
- 高初始带隙基准精度
- 可调软启动
- 预偏置软启动
- **650kHz** 开关频率 (**f_{sw}**)
- 逐周期限流
- 电源正常输出
- 自动跳跃 **Eco-mode™** 为了在轻负载下实现高效率

应用范围

- 低电压系统的广泛应用
 - 数字电视电源
 - 高清 **Blu-ray Disc™** 播放器
 - 网络家庭终端设备
 - 数字机顶盒 (**STB**)

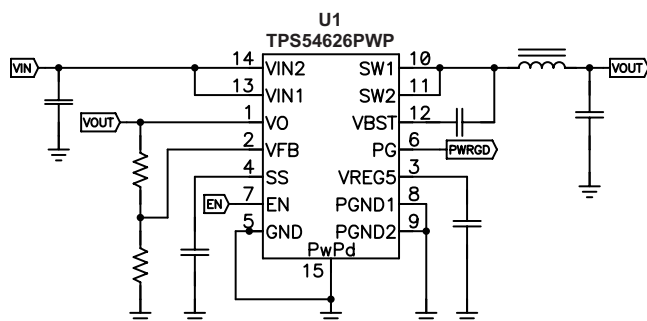

说明

TPS54626 是一款自适应接通时间 D-CAP2™ 模式同步降压转换器。TPS54626 可帮助系统设计人员用成本有效、低组件数量、低待机电流解决方案来完成不同终端设备的电源总线调节器集。TPS54626 的主控制环路采用 D-CAP2™ 模式控制，此模式无需外部补偿组件便可实现极快的瞬态响应。自适应接通时间支持高负载条件下脉宽调制 (PWM) 模式与轻负载下减频运行之间的无缝操作，以实现高效率。TPS54626 的专有电路还可使该器件能够适应诸如高分子聚合物电容器 (SP-CAP) 等低等效串联电阻 (ESR) 输出电容器以及超低 ESR 陶瓷电容器。该器件在 4.5V 至 18V 的 VIN 输入电源电压范围内运行。输出电压可在 0.76V 与 5.5V 之间设定。该器件还特有一个可调软启动时间和一个电源正常功能。TPS54626 采用 14 引脚散热薄型小外形尺寸 (HTSSOP) 封装，设计工作温度介于 -40°至 85° 之间。

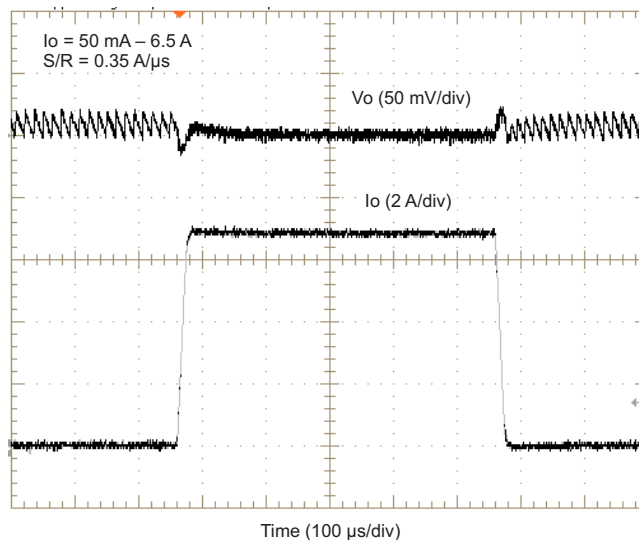

L004_SLVSC34



Please be aware that an important notice concerning availability, standard warranty, and use in critical applications of Texas Instruments semiconductor products and disclaimers thereto appears at the end of this data sheet.

D-CAP2, Eco-mode are trademarks of Texas Instruments.
Blu-ray Disc is a trademark of Blu-ray Disc Association.

PRODUCTION DATA information is current as of publication date. Products conform to specifications per the terms of the Texas Instruments standard warranty. Production processing does not necessarily include testing of all parameters.

Copyright © 2013, Texas Instruments Incorporated
English Data Sheet: [SLVSC34](#)



This integrated circuit can be damaged by ESD. Texas Instruments recommends that all integrated circuits be handled with appropriate precautions. Failure to observe proper handling and installation procedures can cause damage.

ESD damage can range from subtle performance degradation to complete device failure. Precision integrated circuits may be more susceptible to damage because very small parametric changes could cause the device not to meet its published specifications.

ORDERING INFORMATION⁽¹⁾

T _A	PACKAGE ⁽²⁾ ⁽³⁾	ORDERABLE PART NUMBER	PIN	TRANSPORT MEDIA
-45°C to 85°C	PWP	TPS54626PWP	14	Tube
		TPS54626PWPR		Tape and Reel

- (1) For the most current package and ordering information, see the Package Option Addendum at the end of this document, or see the TI web site at www.ti.com.
 (2) Package drawings, thermal data, and symbolization are available at www.ti.com/packaging.
 (3) All package options have Cu NIPDAU lead/ball finish.

ABSOLUTE MAXIMUM RATINGS

over operating free-air temperature range (unless otherwise noted) ⁽¹⁾

			VALUE		UNIT
			MIN	MAX	
V _I	Input voltage range	VIN1, VIN2, EN	-0.3	20	V
		VBST	-0.3	26	V
		VBST (10 ns transient)	-0.3	28	V
		VBST (vs Sw1, SW2)	-0.3	6.5	V
		VFB, VO, SS, PG	-0.3	6.5	V
		SW1, SW2	-2	20	V
		SW1, SW2 (10 ns transient)	-3	22	V
V _O	Output voltage range	VREG5	-0.3	6.5	V
		PGND1, PGND2	-0.3	0.3	V
V _{diff}	Voltage from GND to POWERPAD		-0.2	0.2	V
ESD rating	Electrostatic discharge	Human Body Model (HBM)		2	kV
		Charged Device Model (CDM)		500	V
T _J	Operating junction temperature		-40	150	°C
T _{stg}	Storage temperature		-55	150	°C

- (1) Stresses beyond those listed under *absolute maximum ratings* may cause permanent damage to the device. These are stress ratings only, and functional operation of the device at these or any other conditions beyond those indicated under *recommended operating conditions* is not implied. Exposure to absolute-maximum-rated conditions for extended periods may affect device reliability.

THERMAL INFORMATION

THERMAL METRIC ⁽¹⁾		TPS54626	UNITS
		PWP (14 PINS)	
θ _{JA}	Junction-to-ambient thermal resistance	40.5	°C/W
θ _{JCtop}	Junction-to-case (top) thermal resistance	28.7	
θ _{JB}	Junction-to-board thermal resistance	24.2	
ψ _{JT}	Junction-to-top characterization parameter	0.8	
ψ _{JB}	Junction-to-board characterization parameter	23.9	
θ _{JCbot}	Junction-to-case (bottom) thermal resistance	2.4	

- (1) For more information about traditional and new thermal metrics, see the *IC Package Thermal Metrics* application report, [SPRA953](http://www.ti.com/lit/zip/SR9953).

RECOMMENDED OPERATING CONDITIONS

over operating free-air temperature range (unless otherwise noted)

			MIN	MAX	UNIT
V_{IN}	Supply input voltage range		4.5	18	V
V_I	Input voltage range	VBST	-0.1	24	V
		VBST (10 ns transient)	-0.1	27	
		VBST (vs SW)	-0.1	6.0	
		SS, PG	-0.1	5.7	
		EN	-0.1	18	
		VO, VFB	-0.1	5.5	
		SW1, SW2	-1.8	18	
		SW1, SW2 (10 ns transient)	-3	21	
		PGND1, PGND2	-0.1	0.1	
V_O	Output voltage range	VREG5	-0.1	5.7	V
I_O	Output Current range	I_{VREG5}	0	5	mA
R_{PG}	Power Good resistor		25	150	k Ω
T_A	Operating free-air temperature		-40	85	$^{\circ}$ C
T_J	Operating junction temperature		-40	150	$^{\circ}$ C

ELECTRICAL CHARACTERISTICS

over operating free-air temperature range, $V_{IN} = 12V$ (unless otherwise noted)

PARAMETER		TEST CONDITIONS	MIN	TYP	MAX	UNIT
SUPPLY CURRENT						
I_{VIN}	Operating - non-switching supply current	V_{IN} current, $T_A = 25^{\circ}$ C, EN = 5 V, $V_{VFB} = 0.8$ V		950	1400	μ A
I_{VINSDN}	Shutdown supply current	V_{IN} current, $T_A = 25^{\circ}$ C, EN = 0 V		3.6	10	μ A
LOGIC THRESHOLD						
V_{ENH}	EN high-level input voltage	En	1.6			V
V_{ENL}	EN low-level input voltage	EN			0.6	V
R_{EN}	EN pin resistance to GND	$V_{EN} = 12$ V	200	400	800	k Ω
VFB VOLTAGE AND DISCHARGE RESISTANCE						
V_{FBTH}	VFB threshold voltage	VFB voltage light load mode, $T_A = 25^{\circ}$ C, $V_O = 1.05$ V, $I_O = 10$ mA		772		mV
		$T_A = 25^{\circ}$ C, $V_O = 1.05$ V, continuous mode	757	765	773	
		$T_A = 0^{\circ}$ C to 85° C, $V_O = 1.05$ V, continuous mode ⁽¹⁾	753		777	
		$T_A = -40^{\circ}$ C to 85° C, $V_O = 1.05$ V, continuous mode ⁽¹⁾	751		779	
I_{VFB}	VFB input current	$V_{VFB} = 0.8$ V, $T_A = 25^{\circ}$ C		0	± 0.15	μ A
R_{Dischg}	V_O discharge resistance	$V_{EN} = 0$ V, $V_O = 0.5$ V, $T_A = 25^{\circ}$ C		100	150	Ω
VREG5 OUTPUT						
V_{VREG5}	VREG5 output voltage	$T_A = 25^{\circ}$ C, 6 V < V_{IN} < 18 V, $0 < I_{VREG5} < 5$ mA	5.2	5.5	5.7	V
I_{VREG5}	Output current	$V_{IN} = 6$ V, $V_{VREG5} = 4$ V, $T_A = 25^{\circ}$ C	20			mA
MOSFET						
R_{dsonh}	High side switch resistance	$T_A = 25^{\circ}$ C, VBST-SW1,2 = 5.5V		36		m Ω
R_{dsonl}	Low side switch resistance	$T_A = 25^{\circ}$ C		28		m Ω

(1) Not production tested.

ELECTRICAL CHARACTERISTICS (continued)over operating free-air temperature range, $V_{IN} = 12V$ (unless otherwise noted)

PARAMETER		TEST CONDITIONS	MIN	TYP	MAX	UNIT
CURRENT LIMIT						
I_{ocL}	Current limit	$L = 1.5 \mu H^{(2)}$	7.2	8.2	9.5	A
THERMAL SHUTDOWN						
T_{SDN}	Thermal shutdown threshold	Shutdown temperature ⁽²⁾	165			°C
		Hysteresis ⁽²⁾	35			
ON-TIME TIMER CONTROL						
T_{ON}	On time	$V_{IN} = 12 V, V_O = 1.05 V$	150			ns
$T_{OFF(MIN)}$	Minimum off time	$T_A = 25^\circ C, V_{FB} = 0.7 V$	260	310	ns	
SOFT START						
I_{SSC}	SS charge current	$V_{SS} = 1.0 V$	4.2	6.0	7.8	μA
I_{SSD}	SS discharge current	$V_{SS} = 0.5 V$	1.5	3.3	mA	
POWER GOOD						
V_{THPG}	PG threshold	V_{VFB} rising (good)	85%	90%	95%	
		V_{VFB} falling (fault)	85%			
I_{PG}	PG sink current	$V_{PG} = 0.5 V$	2.5	5	mA	
OUTPUT UNDERVOLTAGE AND OVERVOLTAGE PROTECTION						
V_{OVP}	Output OVP trip threshold	OVP detect	120%	125%	130%	
T_{OVPDEL}	Output OVP prop delay		10			μs
V_{UVP}	Output UVP trip threshold	UVP detect	60%	65%	70%	
		Hysteresis	10%			
T_{UVPDEL}	Output UVP delay		0.25			ms
T_{UVPEN}	Output UVP enable delay	Relative to soft-start time	X 1.7			
UVLO						
V_{UVLO}	UVLO threshold	Wake up VREG5 voltage	3.45	3.75	4.05	V
		Hysteresis VREG5 voltage	0.13	0.32	0.48	

(2) Not production tested.

DEVICE INFORMATION

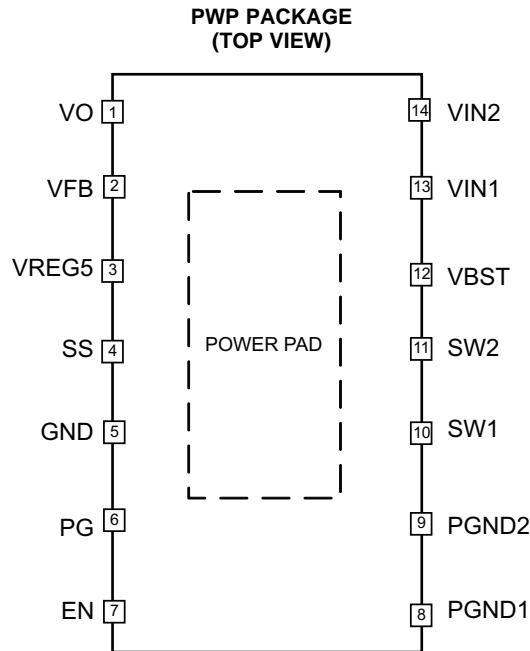

PIN FUNCTIONS

PIN		DESCRIPTION
NAME	NUMBER	
VO	1	Connect to output of converter. This pin is used for output discharge function.
VFB	2	Converter feedback input. Connect with feedback resistor divider.
VREG5	3	5.5V power supply output. A Capacitor (typical 1µF) should be connected to GND. VREG5 is not active when EN is low.
SS	4	Soft start control. An external capacitor should be connected to GND.
GND	5	Signal ground pin.
PG	6	Open drain power good output
EN	7	Enable control input. EN is active high and must be pulled up to enable the device.
PGND1, PGND2	8, 9	Ground returns for low-side MOSFET. Also serve as inputs of current comparators. Connect PGND and GND strongly together near the IC.
SW1, SW2	10,11	Switch node connection between high-side NFET and low-side NFET. Also serve as inputs to current comparator.
VBST	12	Supply input for high-side NFET gate driver (boost terminal). Connect capacitor from this pin to respective SW1,SW2 terminals. An internal PN diode is connected between VREG5 and VBST pin.
VIN1,VIN2	13,14	Power Input and connected to high side NFET drain.
		Supply Input for 5V internal linear regulator for the control circuitry
PowerPAD™	Back side	Thermal pad of the package. Must be soldered to achieve appropriate dissipation. Should be connected to PGND

FUNCTIONAL BLOCK DIAGRAM (HTSSOP)

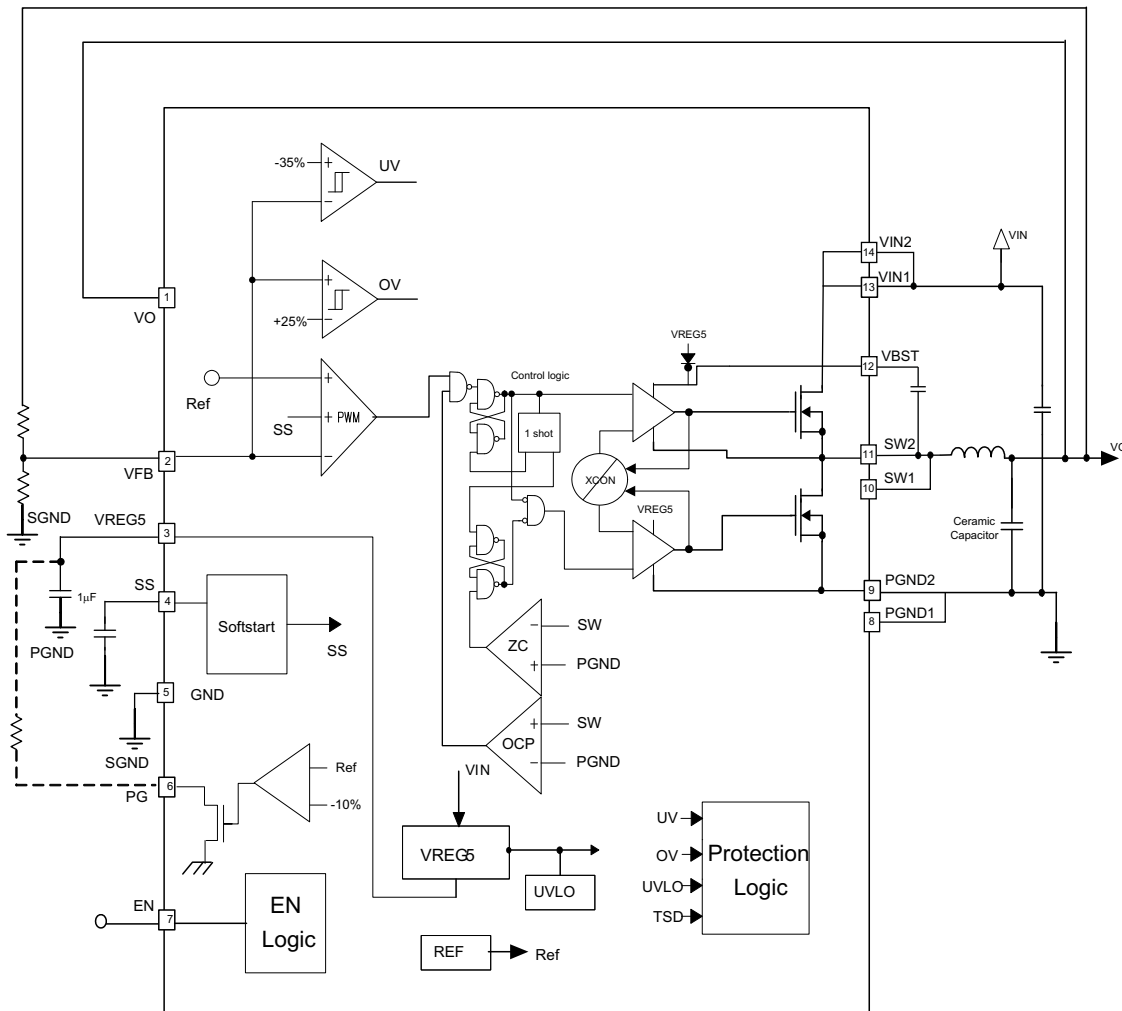

OVERVIEW

The TPS54626 is a 6.5-A synchronous step-down (buck) converter with two integrated N-channel MOSFETs and auto-skip Eco-mode™ to improve light load efficiency. It operates using D-CAP2™ mode control. The fast transient response of D-CAP2™ control reduces the output capacitance required to meet a specific level of performance. Proprietary internal circuitry allows the use of low ESR output capacitors including ceramic and special polymer types.

DETAILED DESCRIPTION

PWM Operation

The main control loop of the TPS54626 is an adaptive on-time pulse width modulation (PWM) controller that supports a proprietary D-CAP2™ mode control. D-CAP2™ mode control combines constant on-time control with an internal compensation circuit for pseudo-fixed frequency and low external component count configuration with both low ESR and ceramic output capacitors. It is stable with virtually no ripple at the output.

At the beginning of each cycle, the high-side MOSFET is turned on. The MOSFET is turned off after the internal one-shot timer expires. The one-shot timer is set by the converter input voltage, V_{IN} , and the output voltage, V_O , to maintain a pseudo-fixed frequency over the input voltage range, hence it is called adaptive on-time control. The one-shot timer is reset and the high-side MOSFET is turned on again when the feedback voltage falls below the reference voltage. An internal ramp is added to reference voltage to simulate output ripple, eliminating the need for ESR induced output ripple from D-CAP2™ mode control.

PWM Frequency and Adaptive On-Time Control

TPS54626 uses an adaptive on-time control scheme and does not have a dedicated on board oscillator. The TPS54626 runs with a pseudo-constant frequency of 650 kHz by using the input voltage and output voltage to set the on-time one-shot timer. The on-time is inversely proportional to the input voltage and proportional to the output voltage. Therefore, when duty ratio is V_{OUT}/V_{IN} , the frequency is constant.

Auto-Skip Eco-Mode™ Control

The TPS54626 is designed with Auto-Skip mode to increase light load efficiency. As the output current decreases from heavy load condition, the inductor current is also reduced and eventually comes to point that its rippled valley touches zero level, which is the boundary between continuous conduction and discontinuous conduction modes. The rectifying MOSFET is turned off when its zero inductor current is detected. As the load current further decreases the converter run into discontinuous conduction mode. The on-time is kept almost the same as is was in the continuous conduction mode so that it takes longer time to discharge the output capacitor with smaller load current to the level of the reference voltage. The transition point to the light load operation $I_{OUT(LL)}$ current can be calculated in [Equation 1](#).

$$I_{OUT(LL)} = \frac{1}{2 \times L \times f_{SW}} \times \frac{(V_{IN} - V_{OUT}) \times V_{OUT}}{V_{IN}} \quad (1)$$

Soft Start and Pre-Biased Soft Start

The soft start function is adjustable. When the EN pin becomes high, 6 μA current begins charging the capacitor which is connected from the SS pin to GND. Smooth control of the output voltage is maintained during start up. The equation for the slow start time is shown in [Equation 2](#). VFB voltage is 0.765 V and SS pin source current is 6 μA .

$$t_{SS(ms)} = \frac{C_{SS}(nF) \times V_{REF} \times 1.1}{I_{SS}(\mu A)} = \frac{C_{SS}(nF) \times 0.765 \times 1.1}{6} \quad (2)$$

TPS54626 contains a unique circuit to prevent current from being pulled from the output during startup if the output is pre-biased. When the soft-start commands a voltage higher than the pre-bias level (internal soft-start becomes greater than feedback voltage V_{FB}), the controller slowly activates synchronous rectification by starting the first low side FET gate driver pulses with a narrow on-time. It then increments that on-time on a cycle-by-cycle basis until it coincides with the time dictated by $(1-D)$, where D is the duty cycle of the converter. This scheme prevents the initial sinking of the pre-bias output, and ensure that the out voltage (V_O) starts and ramps up smoothly into regulation and the control loop is given time to transition from pre-biased start-up to normal mode operation.

Power Good

The TPS54626 has power good open drain output. The power-good function is activated after soft start has finished. The power good function becomes active after 1.7 times soft-start time. When the output voltage becomes within -10% of the target value, internal comparators detect power good state and the power good signal becomes high. Rpg resistor value, which is connected between PG and VREG5, is required from 25k Ω to 150k Ω . If the feedback voltage goes under 15% of the target value, the power good signal becomes low.

Output Discharge Control

TPS54626 discharges the output when EN is low, or the controller is turned off by the protection functions (OVP, UVP, UVLO and thermal shutdown). The device discharges the output using an internal 100- Ω MOSFET which is connected from V_O to PGND. The internal low-side MOSFET is not turned on during the output discharge operation to avoid the possibility of causing negative voltage at the output.

Current Protection

The output over-current protection (OCP) is implemented using a cycle-by-cycle valley detect control circuit. The switch current is monitored by measuring the low-side FET switch voltage between the SW pin and GND. This voltage is proportional to the switch current. To improve accuracy, the voltage sensing is temperature compensated.

During the on time of the high-side FET switch, the switch current increases at a linear rate determined by V_{in} , V_{out} , the on-time and the output inductor value. During the on time of the low-side FET switch, this current decreases linearly. The average value of the switch current is the load current I_{out} . If the measured voltage is above the voltage proportional to the current limit, then the device constantly monitors the low side FET switch voltage, which is proportional to the switch current, during the low-side on-time.

The converter maintains the low-side switch on until the measured voltage is below the voltage corresponding to the current limit at which time the switching cycle is terminated and new switching cycle begins. IN subsequent switching cycles, the on-time is set to fixed value and the current is monitored in the same manner.

There are some important considerations for this type of over-current protection. The load current one half of the peak-to-peak inductor current is higher than the over-current threshold. Also, when the current is being limited, the output voltage tends to fall as the demanded load current may be higher than the current available from the converter. This may cause the output under-voltage protection circuit to be activated. This protection itself is non-latching.

Over/Under Voltage Protection

TPS54626 detects over and under voltage conditions by monitoring the feedback voltage (VFB). This function is enabled after approximately 1.7 x times the softstart time.

When the feedback voltage becomes higher than 125% of the target voltage, the OVP comparator output goes high and the circuit latches and both the high-side MOSFET driver and the low-side MOSFET driver turn off.

When the feedback voltage becomes lower than 65% of the target voltage, the UVP comparator output goes high and an internal UVP delay counter begins. After 250us, the device latches off both internal top and bottom MOSFET.

UVLO Protection

Under voltage lock out protection (UVLO) monitors the voltage of the V_{REG5} pin. When the V_{REG5} voltage is lower than UVLO threshold voltage, the TPS54626 is shut off. This is protection is non-latching.

Thermal Shutdown

Thermal protection is self-activating. If the junction temperature exceeds the threshold value (typically 165°C), the TPS54626 is shut off. This protection is non-latching.

TYPICAL CHARACTERISTICS

$V_{IN} = 12\text{ V}$, $T_A = 25\text{ }^\circ\text{C}$ (unless otherwise noted)

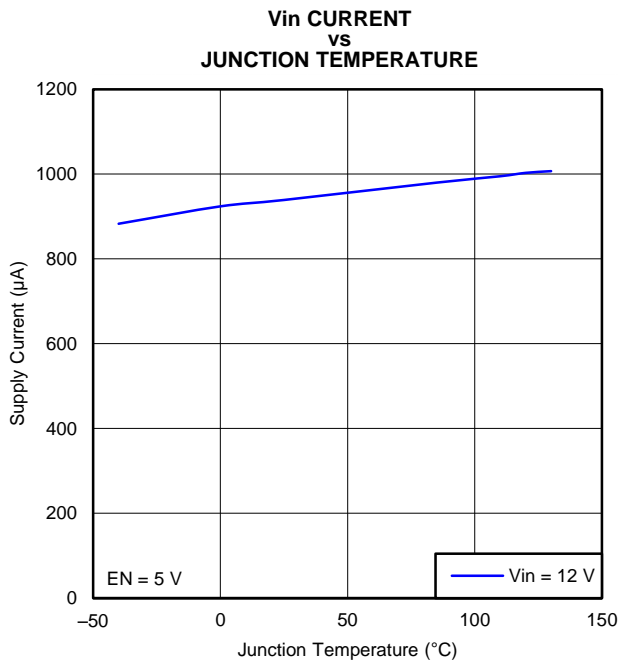

Figure 1.

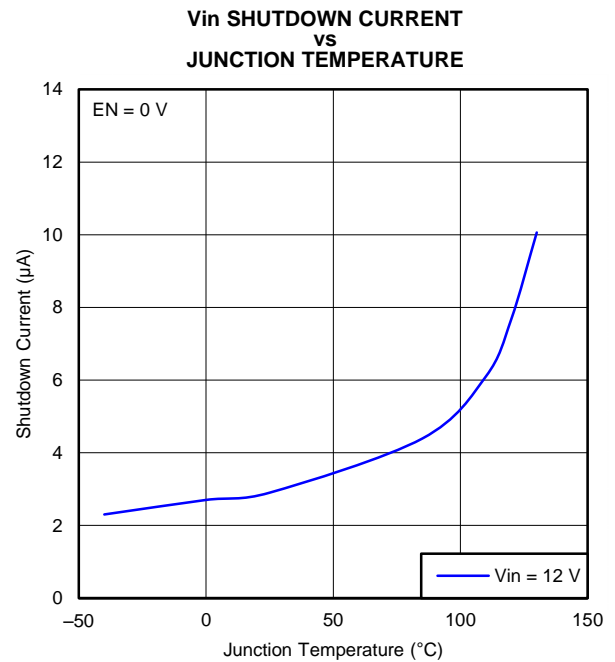

Figure 2.

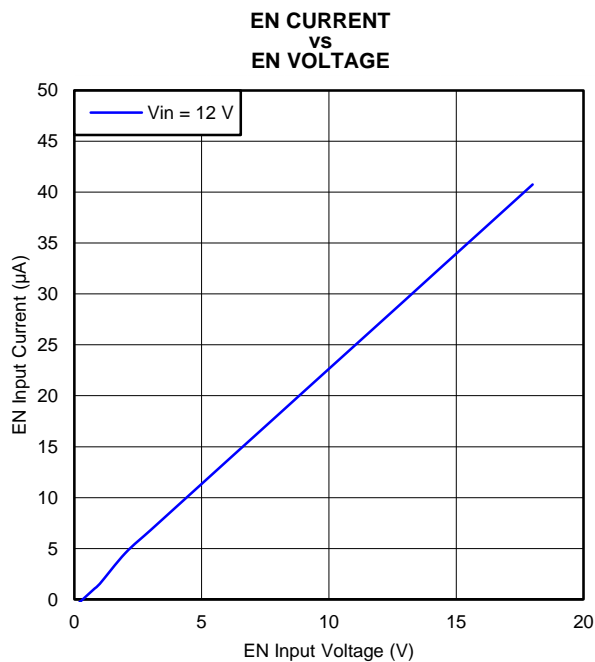

Figure 3.

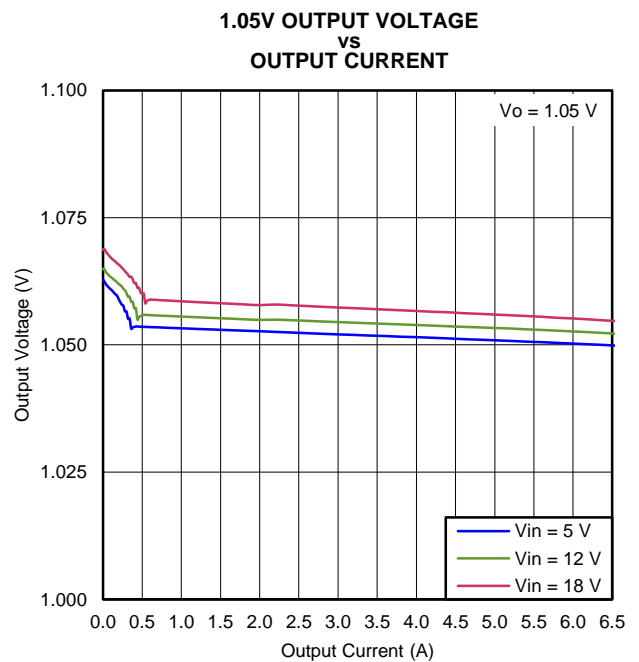

Figure 4.

TYPICAL CHARACTERISTICS (continued)

$V_{IN} = 12\text{ V}$, $T_A = 25\text{ }^\circ\text{C}$ (unless otherwise noted)

**1.05V OUTPUT VOLTAGE
vs
INPUT VOLTAGE**

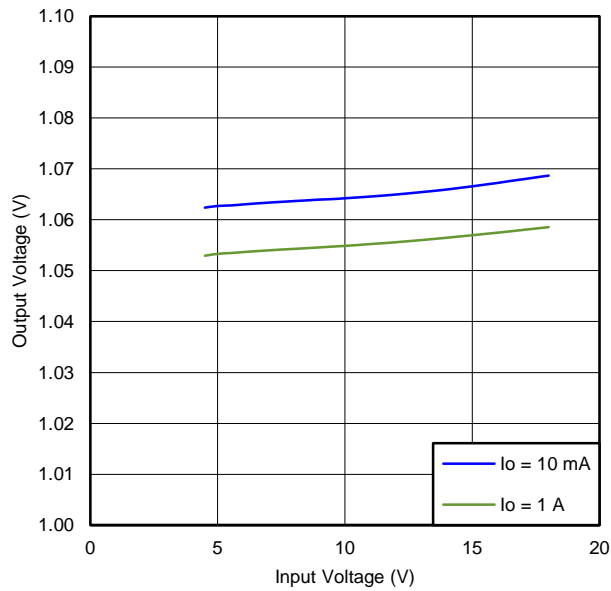

Figure 5.

1.05 V 0.05A to 6.5A LOAD TRANSIENT RESPONSE

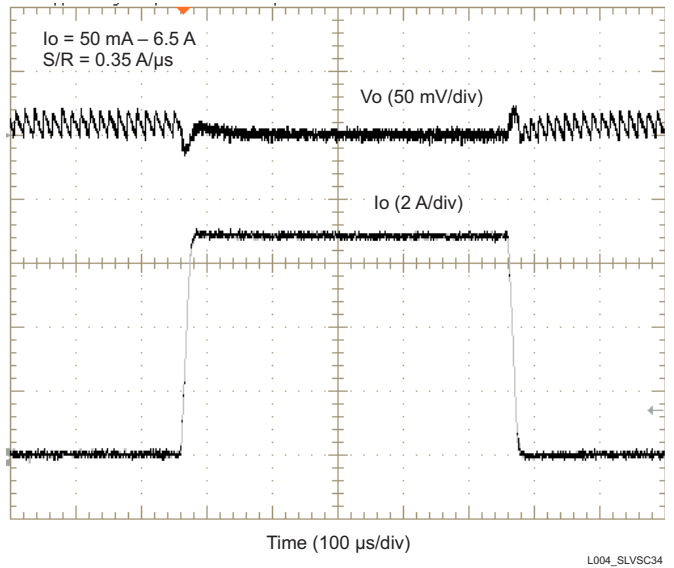

Figure 6.

STARTUP WAVEFORM

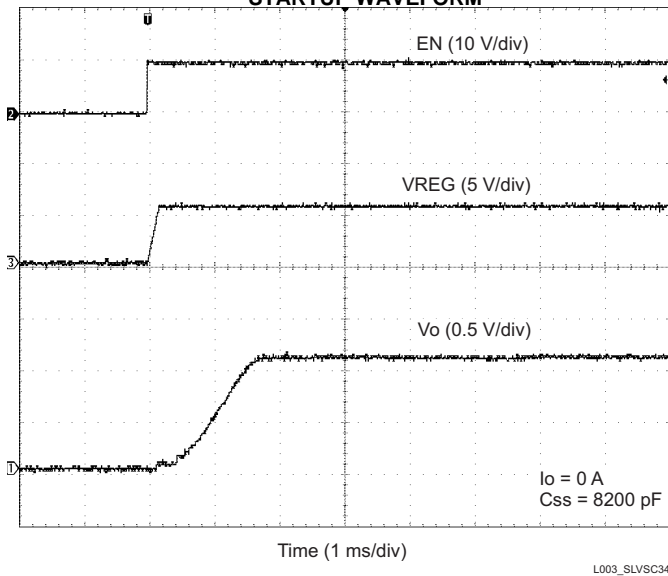

Figure 7.

EFFICIENCY vs OUTPUT CURRENT

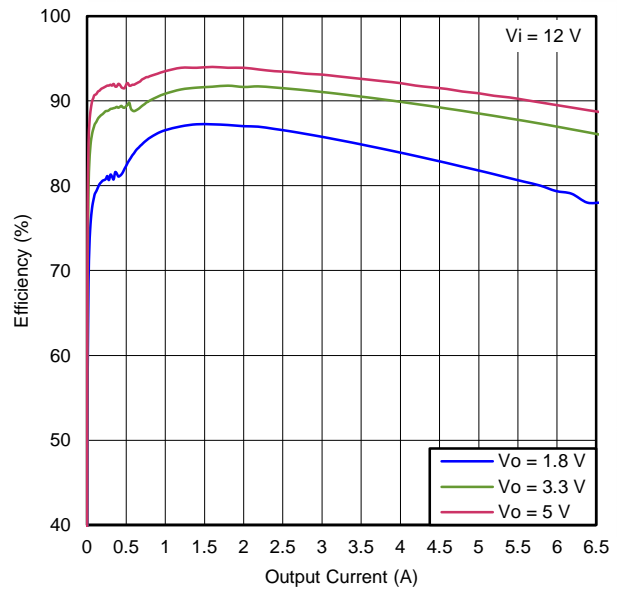

Figure 8.

TYPICAL CHARACTERISTICS (continued)

$V_{IN} = 12\text{ V}$, $T_A = 25\text{ }^\circ\text{C}$ (unless otherwise noted)

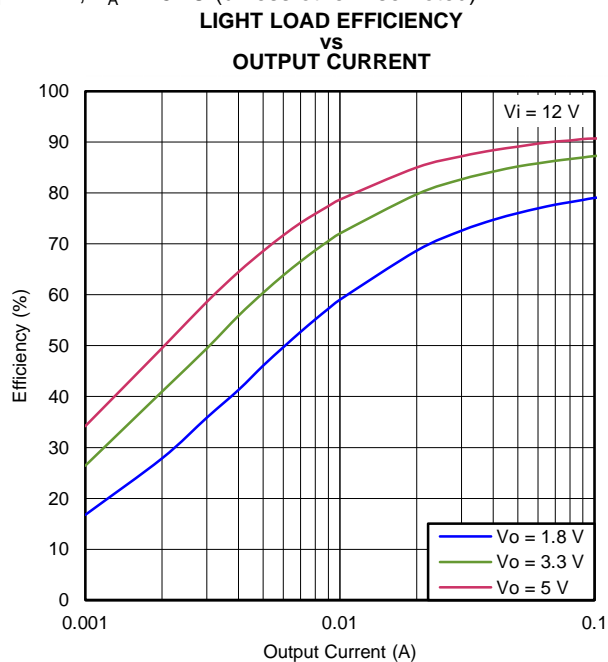

Figure 9.

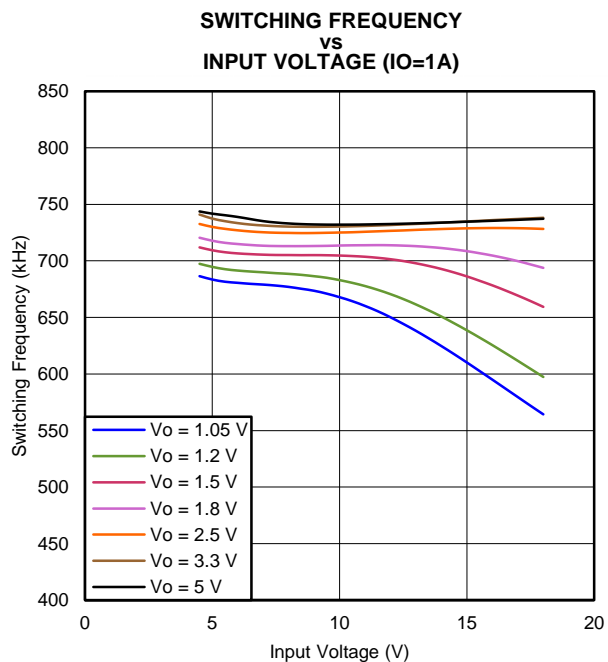

Figure 10.

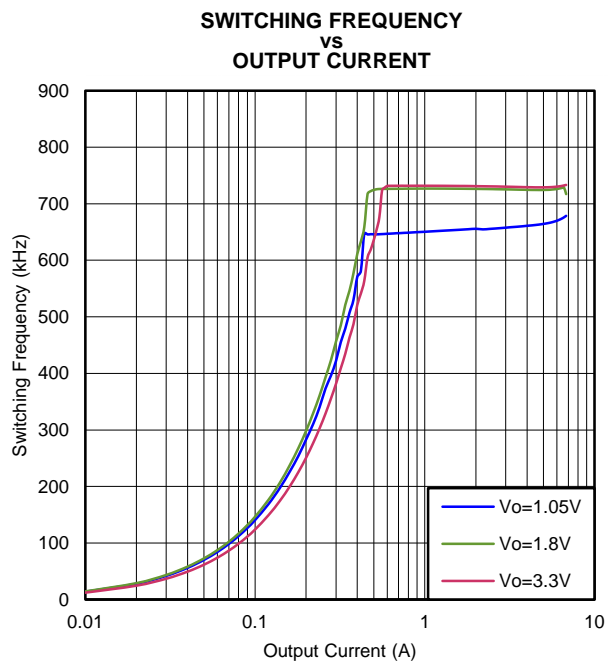

Figure 11.

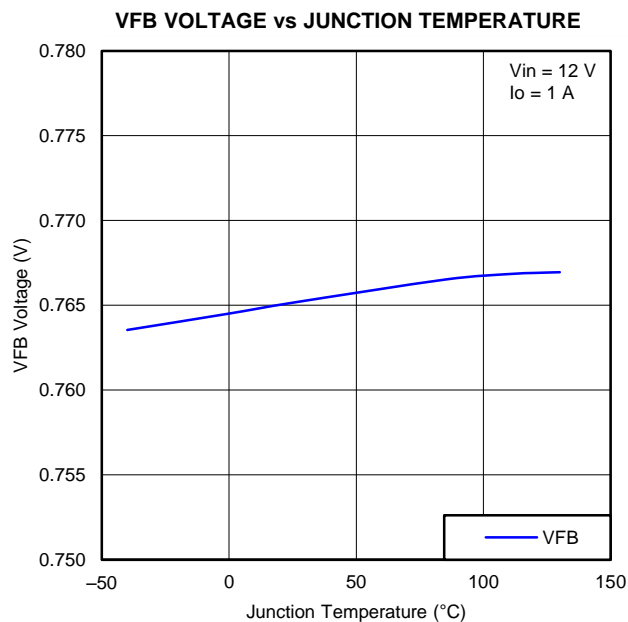

Figure 12.

TYPICAL CHARACTERISTICS (continued)

$V_{IN} = 12\text{ V}$, $T_A = 25\text{ }^\circ\text{C}$ (unless otherwise noted)

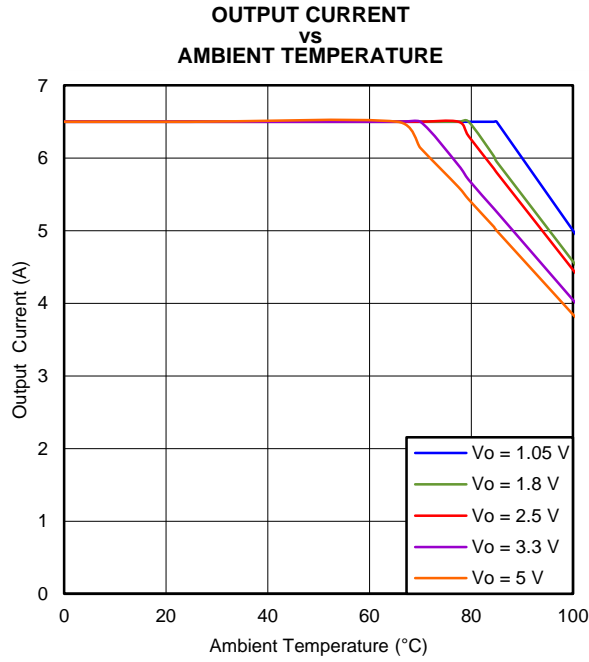

Figure 13.

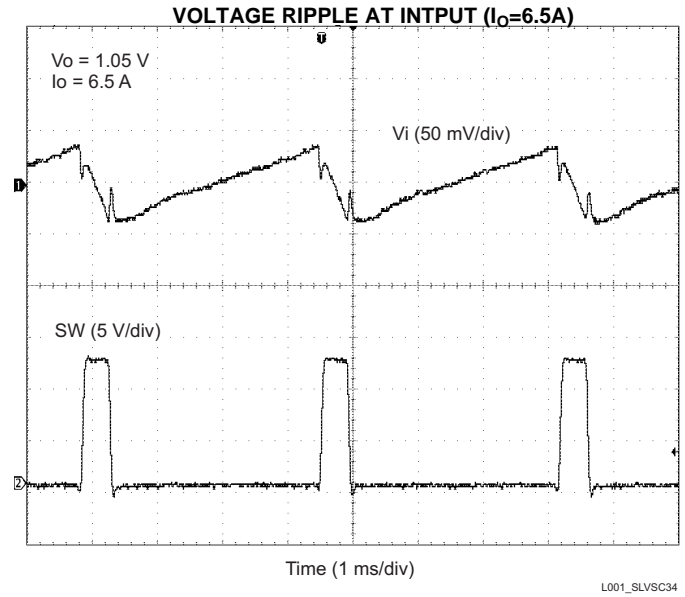

Figure 14.

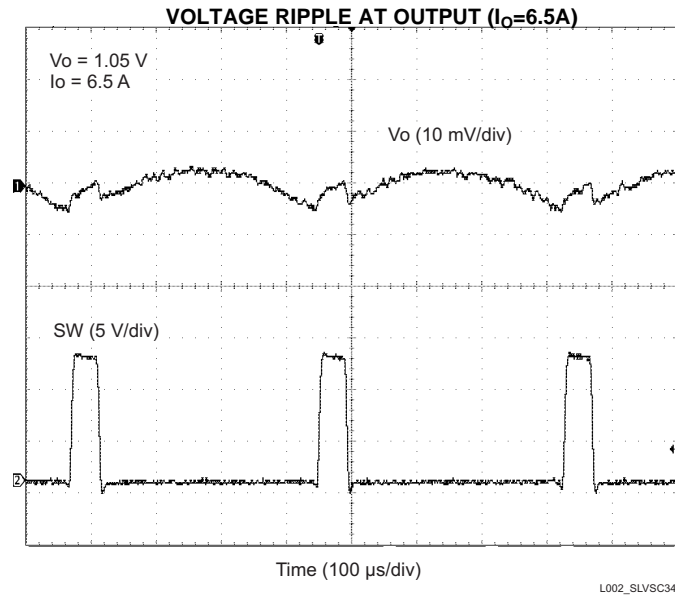

Figure 15.

Table 1. Recommended Component Values

Output Voltage (V)	R1 (kΩ)	R2 (kΩ)	C4 (pF) ⁽¹⁾	L1 (μH)	C8 + C9 (μF)
1	6.81	22.1	5 - 220	1.0 - 1.5 - 4.7	22 - 68
1.05	8.25	22.1	5 - 220	1.0 - 1.5 - 4.7	22 - 68
1.2	12.7	22.1	5 - 100	1.0 - 1.5 - 4.7	22 - 68
1.5	21.5	22.1	5 - 68	1.0 - 1.5 - 4.7	22 - 68
1.8	30.1	22.1	5 - 22	1.2 - 1.5 - 4.7	22 - 68
2.5	49.9	22.1	5 - 22	1.5 - 2.2 - 4.7	22 - 68
3.3	73.2	22.1	5 - 22	1.8 - 2.2 - 4.7	22 - 68
5	124	22.1	5 - 22	2.5 - 3.3 - 4.7	22 - 68

(1) Optional

For higher output voltages at or above 1.8 V, additional phase boost can be achieved by adding a feed forward capacitor (C4) in parallel with R1.

The inductor peak-to-peak ripple current, peak current and RMS current are calculated using Equation 5, Equation 6 and Equation 7. The inductor saturation current rating must be greater than the calculated peak current and the RMS or heating current rating must be greater than the calculated RMS current. Use 650 kHz for f_{SW} .

Use 650 kHz for f_{SW} , and also use 1.5μH for LO. Make sure the chosen inductor is rated for the peak current of Equation 6 and the RMS current of Equation 7.

$$I_{pp} - p = \frac{V_{OUT}}{V_{IN(max)}} \cdot \frac{V_{IN(max)} - V_{OUT}}{L_O \cdot f_{SW}} \quad (5)$$

$$I_{Ipeak} = I_O + \frac{I_{pp} - p}{2} \quad (6)$$

$$I_{Lo(RMS)} = \sqrt{I_O^2 + \frac{1}{12} I_{pp} - p^2} \quad (7)$$

For this design example, the calculated peak current is 7.01 A and the calculated RMS current is 6.51 A. The inductor used is a TDK SPM6530-1R5M100 with a peak current rating of 11.5 A and an RMS current rating of 11 A.

The capacitor value and ESR determines the amount of output voltage ripple. The TPS54626 is intended for use with ceramic or other low ESR capacitors. Recommended values range from 22μF to 68μF. Use Equation 8 to determine the required RMS current rating for the output capacitor

$$I_{CO(RMS)} = \frac{V_{OUT} \cdot (V_{IN} - V_{OUT})}{\sqrt{12} \cdot V_{IN} \cdot L_O \cdot f_{SW}} \quad (8)$$

For this design two TDK C3216X5R0J226M 22μF output capacitors are used. The typical ESR is 2 mΩ each. The calculated RMS current is 0.284 A and each output capacitor is rated for 4 A.

Input Capacitor Selection

The TPS54626 requires an input decoupling capacitor and a bulk capacitor is needed depending on the application. A ceramic capacitor over 10 μF is recommended for the decoupling capacitor. An additional 0.1 μF capacitor from pin 14 to ground is recommended to improve the stability of the over-current limit function. The capacitor voltage rating needs to be greater than the maximum input voltage.

Bootstrap Capacitor Selection

A 0.1-μF ceramic capacitor must be connected between the VBST to SW pin for proper operation. It is recommended to use a ceramic capacitor.

VREG5 Capacitor Selection

A 1-μF ceramic capacitor must be connected between the VREG5 to GND pin for proper operation. It is recommended to use a ceramic capacitor.

THERMAL INFORMATION

This PowerPad™ package incorporates an exposed thermal pad that is designed to be directly to an external heatsink. The thermal pad must be soldered directly to the printed board (PCB). After soldering, the PCB can be used as a heatsink. In addition, through the use of thermal vias, the thermal pad can be attached directly to the appropriate copper plane shown in the electrical schematic for the device, or alternatively, can be attached to a special heatsink structure designed into the PCB. This design optimizes the heat transfer from the integrated circuit (IC).

For additional information on the PowerPAD™ package and how to use the advantage of its heat dissipating abilities, refer to Technical Brief, *PowerPAD™ Thermally Enhanced Package*, Texas Instruments Literature No. [SLMA002](#) and Application Brief, *PowerPAD™ Made Easy*, Texas Instruments Literature No. [SLMA004](#).

The exposed thermal pad dimensions for this package are shown in the following illustration.

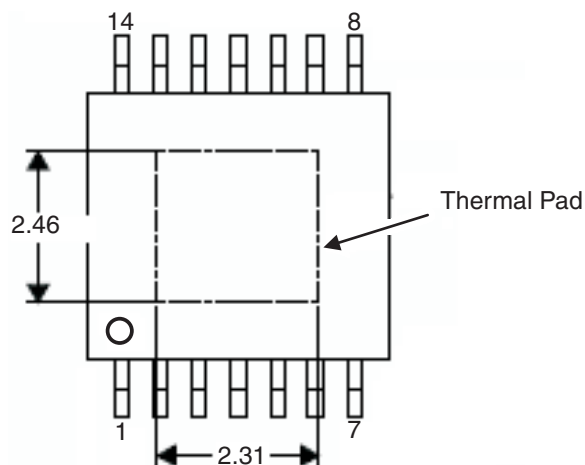

Figure 17. Thermal Pad Dimensions

LAYOUT CONSIDERATIONS

1. A top side area should be filled with ground as much as possible due to relatively higher current output device.
2. The ground area under the device thermal pad should be large as possible and directly connect to the thermal pad. Also 2nd, 3rd and 4th PCB layer should be connected to ground directly from the thermal pad.
3. Keep the input switching current loop as small as possible.
4. Keep the SW node as physically small and short as possible to minimize parasitic capacitance and inductance and to minimize radiated emissions. Kelvin connections should be brought from the output to the feedback pin of the device.
5. Keep analog and non-switching components away from switching components.
6. Make a single point connection from the signal ground to power ground.
7. Do not allow switching current to flow under the device.
8. Keep the pattern lines for VIN and PGND broad.
9. Exposed pad of device must be connected to PGND with solder.
10. VREG5 capacitor should be placed near the device, and connected PGND.
11. Output capacitor should be connected to a broad pattern of the PGND.
12. Voltage feedback loop should be as short as possible, and preferably with ground shield.
13. Lower resistor of the voltage divider which is connected to the VFB pin should be tied to SGND.
14. Providing sufficient via is preferable for VIN, SW and PGND connection.
15. PCB pattern for VIN, SW, and PGND should be as broad as possible.
16. VIN Capacitor should be placed as near as possible to the device.

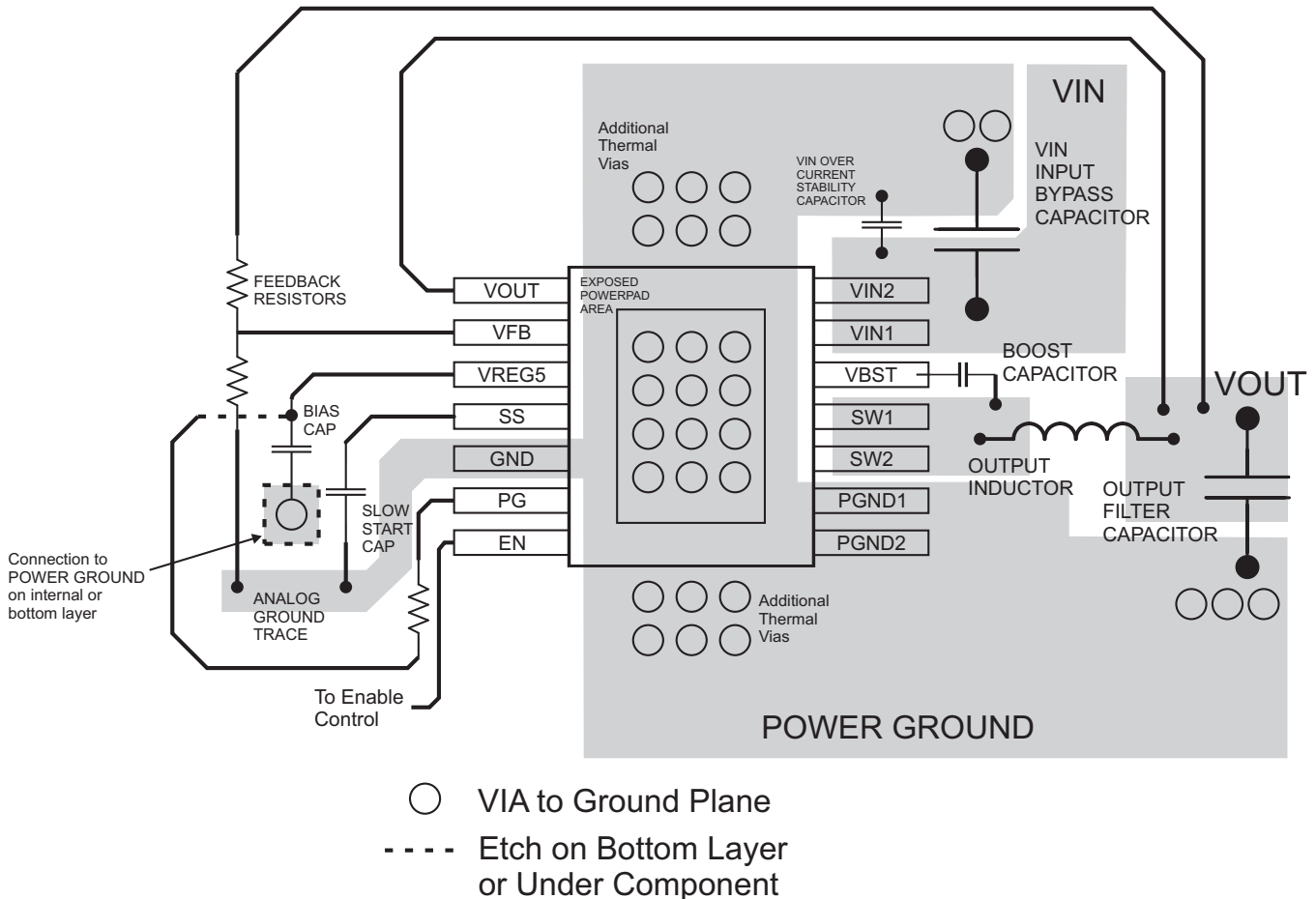

Figure 18. PCB Layout for PWP Package

PACKAGING INFORMATION

Orderable Device	Status (1)	Package Type	Package Drawing	Pins	Package Qty	Eco Plan (2)	Lead/Ball Finish	MSL Peak Temp (3)	Op Temp (°C)	Device Marking (4/5)	Samples
TPS54626PWP	ACTIVE	HTSSOP	PWP	14	90	Green (RoHS & no Sb/Br)	CU NIPDAU	Level-2-260C-1 YEAR	-40 to 85	PS54626	Samples
TPS54626PWPR	ACTIVE	HTSSOP	PWP	14	2000	Green (RoHS & no Sb/Br)	CU NIPDAU	Level-2-260C-1 YEAR	-40 to 85	PS54626	Samples

(1) The marketing status values are defined as follows:

ACTIVE: Product device recommended for new designs.

LIFEBUY: TI has announced that the device will be discontinued, and a lifetime-buy period is in effect.

NRND: Not recommended for new designs. Device is in production to support existing customers, but TI does not recommend using this part in a new design.

PREVIEW: Device has been announced but is not in production. Samples may or may not be available.

OBSELETE: TI has discontinued the production of the device.

(2) Eco Plan - The planned eco-friendly classification: Pb-Free (RoHS), Pb-Free (RoHS Exempt), or Green (RoHS & no Sb/Br) - please check <http://www.ti.com/productcontent> for the latest availability information and additional product content details.

TBD: The Pb-Free/Green conversion plan has not been defined.

Pb-Free (RoHS): TI's terms "Lead-Free" or "Pb-Free" mean semiconductor products that are compatible with the current RoHS requirements for all 6 substances, including the requirement that lead not exceed 0.1% by weight in homogeneous materials. Where designed to be soldered at high temperatures, TI Pb-Free products are suitable for use in specified lead-free processes.

Pb-Free (RoHS Exempt): This component has a RoHS exemption for either 1) lead-based flip-chip solder bumps used between the die and package, or 2) lead-based die adhesive used between the die and leadframe. The component is otherwise considered Pb-Free (RoHS compatible) as defined above.

Green (RoHS & no Sb/Br): TI defines "Green" to mean Pb-Free (RoHS compatible), and free of Bromine (Br) and Antimony (Sb) based flame retardants (Br or Sb do not exceed 0.1% by weight in homogeneous material)

(3) MSL, Peak Temp. -- The Moisture Sensitivity Level rating according to the JEDEC industry standard classifications, and peak solder temperature.

(4) There may be additional marking, which relates to the logo, the lot trace code information, or the environmental category on the device.

(5) Multiple Device Markings will be inside parentheses. Only one Device Marking contained in parentheses and separated by a "~" will appear on a device. If a line is indented then it is a continuation of the previous line and the two combined represent the entire Device Marking for that device.

Important Information and Disclaimer:The information provided on this page represents TI's knowledge and belief as of the date that it is provided. TI bases its knowledge and belief on information provided by third parties, and makes no representation or warranty as to the accuracy of such information. Efforts are underway to better integrate information from third parties. TI has taken and continues to take reasonable steps to provide representative and accurate information but may not have conducted destructive testing or chemical analysis on incoming materials and chemicals. TI and TI suppliers consider certain information to be proprietary, and thus CAS numbers and other limited information may not be available for release.

In no event shall TI's liability arising out of such information exceed the total purchase price of the TI part(s) at issue in this document sold by TI to Customer on an annual basis.

PWP (R-PDSO-G14)

PowerPAD™ PLASTIC SMALL OUTLINE

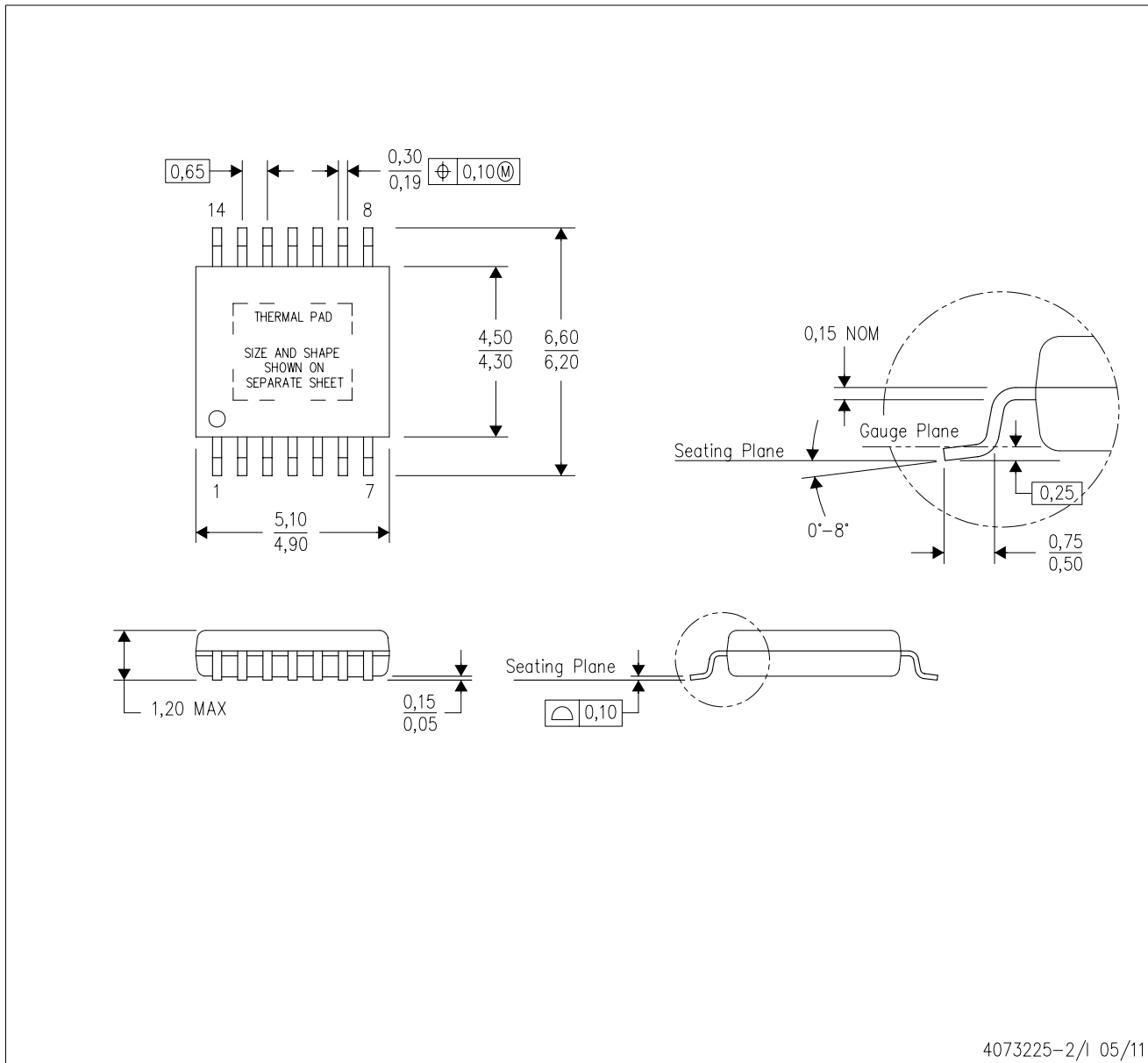

4073225-2/1 05/11

- NOTES:
- All linear dimensions are in millimeters.
 - This drawing is subject to change without notice.
 - Body dimensions do not include mold flash or protrusions. Mold flash and protrusion shall not exceed 0.15 per side.
 - This package is designed to be soldered to a thermal pad on the board. Refer to Technical Brief, PowerPad Thermally Enhanced Package, Texas Instruments Literature No. SLMA002 for information regarding recommended board layout. This document is available at www.ti.com <<http://www.ti.com>>.
 - See the additional figure in the Product Data Sheet for details regarding the exposed thermal pad features and dimensions.
 - Falls within JEDEC MO-153

PowerPAD is a trademark of Texas Instruments.

PWP (R-PDSO-G14) PowerPAD™ SMALL PLASTIC OUTLINE

THERMAL INFORMATION

This PowerPAD™ package incorporates an exposed thermal pad that is designed to be attached to a printed circuit board (PCB). The thermal pad must be soldered directly to the PCB. After soldering, the PCB can be used as a heatsink. In addition, through the use of thermal vias, the thermal pad can be attached directly to the appropriate copper plane shown in the electrical schematic for the device, or alternatively, can be attached to a special heatsink structure designed into the PCB. This design optimizes the heat transfer from the integrated circuit (IC).

For additional information on the PowerPAD package and how to take advantage of its heat dissipating abilities, refer to Technical Brief, PowerPAD Thermally Enhanced Package, Texas Instruments Literature No. SLMA002 and Application Brief, PowerPAD Made Easy, Texas Instruments Literature No. SLMA004. Both documents are available at www.ti.com.

The exposed thermal pad dimensions for this package are shown in the following illustration.

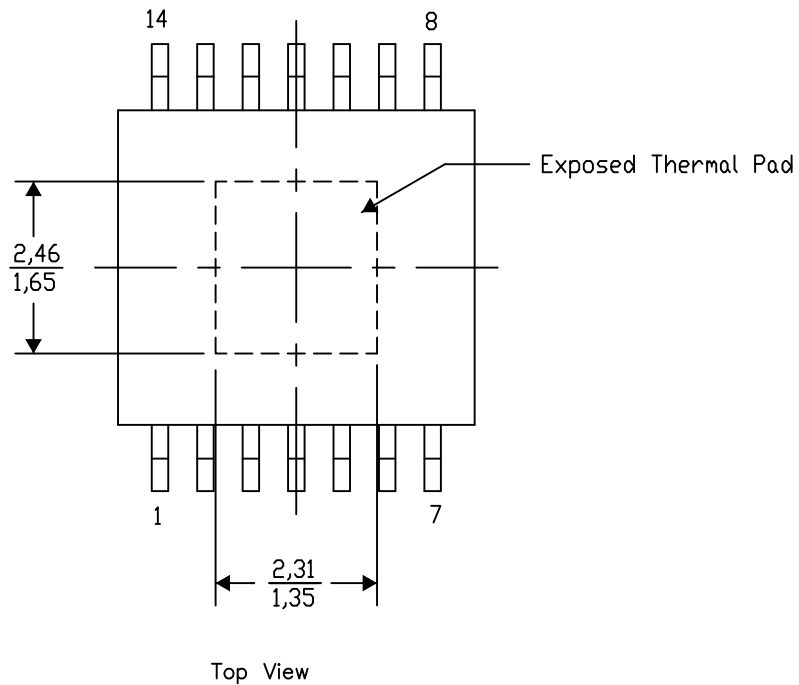

Exposed Thermal Pad Dimensions

4206332-2/AO 01/16

NOTE: A. All linear dimensions are in millimeters

PowerPAD is a trademark of Texas Instruments

PWP (R-PDSO-G14)

PowerPAD™ PLASTIC SMALL OUTLINE

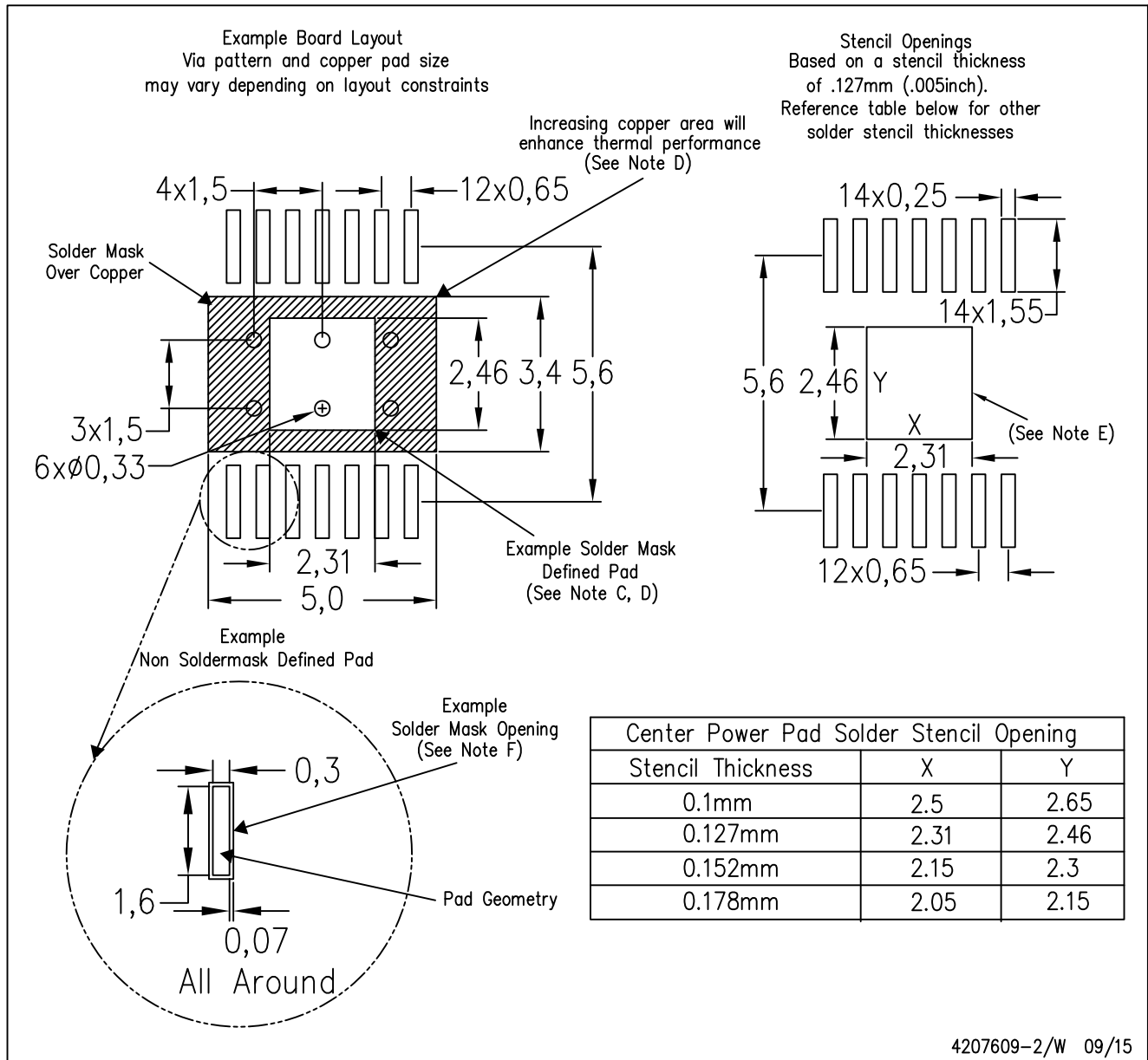

4207609-2/W 09/15

- NOTES:
- A. All linear dimensions are in millimeters.
 - B. This drawing is subject to change without notice.
 - C. Customers should place a note on the circuit board fabrication drawing not to alter the center solder mask defined pad.
 - D. This package is designed to be soldered to a thermal pad on the board. Refer to Technical Brief, PowerPAD Thermally Enhanced Package, Texas Instruments Literature No. SLMA002, SLMA004, and also the Product Data Sheets for specific thermal information, via requirements, and recommended board layout. These documents are available at www.ti.com <<http://www.ti.com>>. Publication IPC-7351 is recommended for alternate designs.
 - E. Laser cutting apertures with trapezoidal walls and also rounding corners will offer better paste release. Customers should contact their board assembly site for stencil design recommendations. Example stencil design based on a 50% volumetric metal load solder paste. Refer to IPC-7525 for other stencil recommendations.
 - F. Customers should contact their board fabrication site for solder mask tolerances between and around signal pads.

重要声明

德州仪器 (TI) 公司有权按照最新发布的 JESD46 对其半导体产品和服务进行纠正、增强、改进和其他修改，并不再按最新发布的 JESD48 提供任何产品和服务。买方在下订单前应获取最新的相关信息，并验证这些信息是否完整且是最新的。

TI 公布的半导体产品销售条款 (<http://www.ti.com/sc/docs/stdterms.htm>) 适用于 TI 已认证和批准上市的已封装集成电路产品的销售。另有其他条款可能适用于其他类型 TI 产品及服务的使用或销售。

复制 TI 数据表上 TI 信息的重要部分时，不得变更该等信息，且必须随附所有相关保证、条件、限制和通知，否则不得复制。TI 对该等复制文件不承担任何责任。第三方信息可能受到其它限制条件的制约。在转售 TI 产品或服务时，如果存在对产品或服务参数的虚假陈述，则会失去相关 TI 产品或服务的明示或暗示保证，且构成不公平的、欺诈性商业行为。TI 对此类虚假陈述不承担任何责任。

买方和在系统中整合 TI 产品的其他开发人员（总称“设计人员”）理解并同意，设计人员在设计应用时应自行实施独立的分析、评价和判断，且应全权负责并确保应用的安全性，及设计人员的应用（包括应用中使用的 TI 产品）应符合所有适用的法律法规及其他相关要求。设计人员就自己设计的应用声明，其具备制订和实施下列保障措施所需的一切必要专业知识，能够 (1) 预见故障的危险后果，(2) 监视故障及其后果，以及 (3) 降低可能导致危险的故障几率并采取适当措施。设计人员同意，在使用或分发包含 TI 产品的任何应用前，将彻底测试该等应用和该等应用中所用 TI 产品的功能。

TI 提供技术、应用或其他设计建议、质量特点、可靠性数据或其他服务或信息，包括但不限于与评估模块有关的参考设计和材料（总称“TI 资源”），旨在帮助设计人员开发整合了 TI 产品的应用，如果设计人员（个人，或如果是代表公司，则为设计人员的公司）以任何方式下载、访问或使用任何特定的 TI 资源，即表示其同意仅为该等目标，按照本通知的条款使用任何特定 TI 资源。

TI 所提供的 TI 资源，并未扩大或以其他方式修改 TI 对 TI 产品的公开适用的质保及质保免责声明；也未导致 TI 承担任何额外的义务或责任。TI 有权对其 TI 资源进行纠正、增强、改进和其他修改。除特定 TI 资源的公开文档中明确列出的测试外，TI 未进行任何其他测试。

设计人员只有在开发包含该等 TI 资源所列 TI 产品的应用时，才被授权使用、复制和修改任何相关 TI 资源。但并未依据禁止反言原则或其他法律授予您任何 TI 知识产权的任何其他明示或默示的许可，也未授予您 TI 或第三方的任何技术或知识产权的许可，该等许可包括但不限于任何专利权、版权、屏蔽作品权或与美国 TI 产品或服务的任何整合、机器制作、流程相关的其他知识产权。涉及或参考了第三方产品或服务的信息不构成使用此类产品或服务的许可或与其相关的保证或认可。使用 TI 资源可能需要您向第三方获得对该等第三方专利或其他知识产权的许可。

TI 资源系“按原样”提供。TI 兹免除对资源及其使用作出所有其他明确或默示的保证或陈述，包括但不限于对准确性或完整性、产权保证、无屡发故障保证，以及适销性、适合特定用途和不侵犯任何第三方知识产权的任何默认保证。TI 不负责任何申索，包括但不限于因组合产品所致或与之有关的申索，也不为或对设计人员进行辩护或赔偿，即使该等产品组合已列于 TI 资源或其他地方。对因 TI 资源或其使用引起或与之有关的任何实际的、直接的、特殊的、附带的、间接的、惩罚性的、偶发的、从属或惩戒性损害赔偿，不管 TI 是否获悉可能会产生上述损害赔偿，TI 概不负责。

除 TI 已明确指出特定产品已达到特定行业标准（例如 ISO/TS 16949 和 ISO 26262）的要求外，TI 不对未达到任何该等行业标准要求而承担任何责任。

如果 TI 明确宣称产品有助于功能安全或符合行业功能安全标准，则该等产品旨在帮助客户设计和创作自己的符合相关功能安全标准和要求的的应用。在应用内使用产品的行为本身不会配有安全特性。设计人员必须确保遵守适用于其应用的相关安全要求和标准。设计人员不可将任何 TI 产品用于关乎性命的医疗设备，除非已由各方获得授权的管理人员签署专门的合同对此类应用专门作出规定。关乎性命的医疗设备是指出现故障会导致严重身体伤害或死亡的医疗设备（例如生命保障设备、心脏起搏器、心脏除颤器、人工心脏泵、神经刺激器以及植入设备）。此类设备包括但不限于，美国食品药品监督管理局认定为 III 类设备的设备，以及在美国以外的其他国家或地区认定为同等类别设备的所有医疗设备。

TI 可能明确指定某些产品具备某些特定资格（例如 Q100、军用级或增强型产品）。设计人员同意，其具备一切必要专业知识，可以为自己的应用选择适合的产品，并且正确选择产品的风险由设计人员承担。设计人员单方面负责遵守与该等选择有关的所有法律或监管要求。

设计人员同意向 TI 及其代表全额赔偿因其不遵守本通知条款和条件而引起的任何损害、费用、损失和/或责任。

邮寄地址：上海市浦东新区世纪大道 1568 号中建大厦 32 楼，邮政编码：200122
Copyright © 2017 德州仪器半导体技术（上海）有限公司