

采用增强型航天塑料的 TPS73801-SEP 1A 低噪声快速瞬态响应低压降稳压器

1 特性

- VID V62/18616
- 耐辐射
 - 单粒子锁定 (SEL) 在 125°C 下的抗扰度可达 43MeV-cm²/mg
 - 每个晶圆批次的 RLAT 总电离剂量 (TID) 高达 20krad(Si)
- 增强型航天塑料
 - 受控基线
 - 金线
 - NiPdAu 铅涂层
 - 同一组装和测试场所
 - 同一制造场所
 - 支持军用 (-55°C 至 125°C) 温度范围
 - 延长的产品生命周期
 - 延长的产品变更通知
 - 产品可追溯性
 - 采用增强型模具化合物实现低释气
- 针对快速瞬态响应进行了优化
- 输出电流: 1A
- 压降电压: 300mV
- 低噪声: 45μV_{RMS} (10Hz 至 100kHz)
- 1mA 静态电流
- 无需保护二极管
- 压降中的受控静态电流
- 可调节输出电压: 1.21V 至 20V
- 关断模式下静态电流小于 1μA
- 与 10μF 输出电容器一起工作时保持稳定
- 与陶瓷电容器一起工作时保持稳定
- 电池反向保护
- 无反向电流
- 热限制

2 应用

- 支持近地轨道空间应用
- 用于射频、VCO、接收器和放大器的耐辐射低噪声线性稳压器
- 洁净模拟电源要求
- 航天卫星有效载荷

3 说明

TPS73801-SEP 是一款针对快速瞬态响应进行了优化的低压降 (LDO) 稳压器。该器件能够支持 1A 的输出电流 (压降为 300mV)。工作静态电流为 1mA, 在关断时下降至小于 1μA。静态电流受到很好的控制; 与许多其他稳压器一样, 它在压降时不上升。除了快速瞬态响应, TPS73801 稳压器还具有极低的输出噪声, 这使得它非常适合灵敏射频电源应用。

输出电压范围为 1.21 至 20V。TPS73801-SEP 稳压器可在与低至 10μF 的输出电容器一起工作时保持稳定。与其它稳压器一同使用时的常见情况一样, 在无需额外等效串联电阻 (ESR) 的前提下可使用小型陶瓷电容器。内部保护电路包括反向电池保护、电流限制、热限制和反向电流保护。此器件可被用作一个基准电压为 1.21V 的可调器件。TPS73801-SEP 稳压器采用 6 引脚 TO-223 (DCQ) 封装。

器件信息⁽¹⁾

| 器件型号 | 等级 | 封装 |
|-------------------|-----------------|-------------|
| TPS73801MDCQTPSEP | 20krad(Si) RLAT | SOT-223 (6) |
| TPS73801MDCQPSEP | | |

(1) 如需了解所有可用封装, 请参阅数据表末尾的可订购产品附录。

简化原理图

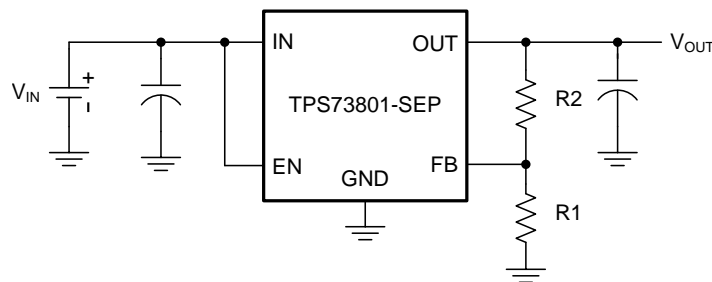

目录

| | | | | | |
|----------|--|----|-----------|---|----|
| 1 | 特性 | 1 | 7.4 | Device Functional Modes | 12 |
| 2 | 应用 | 1 | 8 | Application and Implementation | 13 |
| 3 | 说明 | 1 | 8.1 | Application Information | 13 |
| 4 | 修订历史记录 | 2 | 8.2 | Typical Application | 13 |
| 5 | Pin Configuration and Functions | 3 | 9 | Power Supply Recommendations | 15 |
| 6 | Specifications | 4 | 10 | Layout | 15 |
| 6.1 | Absolute Maximum Ratings | 4 | 10.1 | Layout Guidelines | 15 |
| 6.2 | ESD Ratings | 4 | 10.2 | Layout Example | 16 |
| 6.3 | Recommended Operating Conditions | 4 | 10.3 | Thermal Considerations | 16 |
| 6.4 | Thermal Information | 4 | 11 | 器件和文档支持 | 18 |
| 6.5 | Electrical Characteristics | 5 | 11.1 | 接收文档更新通知 | 18 |
| 6.6 | Typical Characteristics | 6 | 11.2 | 社区资源 | 18 |
| 7 | Detailed Description | 10 | 11.3 | 商标 | 18 |
| 7.1 | Overview | 10 | 11.4 | 静电放电警告 | 18 |
| 7.2 | Functional Block Diagram | 10 | 11.5 | 术语表 | 18 |
| 7.3 | Feature Description | 10 | 12 | 机械、封装和可订购信息 | 19 |

4 修订历史记录

注：之前版本的页码可能与当前版本有所不同。

| 日期 | 修订版本 | 说明 |
|-------------|------|--------|
| 2018 年 12 月 | * | 初始发行版。 |

5 Pin Configuration and Functions

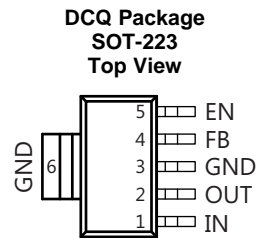

| PIN | | I/O | DESCRIPTION |
|-----|------|-----|--|
| NO. | NAME | | |
| 1 | IN | — | Input. Power is supplied to the device through the IN pin. A bypass capacitor is required on this pin if the device is more than six inches away from the main input filter capacitor. In general, the output impedance of a battery rises with frequency, so it is advisable to include a bypass capacitor in battery-powered circuits. A bypass capacitor (ceramic) in the range of 1 μF to 10 μF is sufficient. The TPS73801-SEP regulators are designed to withstand reverse voltages on the IN pin with respect to ground and the OUT pin. In the case of a reverse input, which can happen if a battery is plugged in backwards, the device acts as if there is a diode in series with its input. There is no reverse current flow into the regulator, and no reverse voltage appears at the load. The device protects both itself and the load. |
| 2 | OUT | — | Output. The output supplies power to the load. A minimum output capacitor (ceramic) of 10 μF is required to prevent oscillations. Larger output capacitors are required for applications with large transient loads to limit peak voltage transients. |
| 3 | GND | — | Ground. |
| 4 | FB | I | Feedback. This is the input to the error amplifier. This pin is internally clamped to ± 7 V. It has a bias current of 3 μA that flows into the pin. The FB pin voltage is 1.21 V referenced to ground, and the output voltage range is 1.21 V to 20 V. |
| 5 | EN | I | Enable. The EN pin is used to put the TPS73801-SEP regulators into a low-power shutdown state. The output is off when the EN pin is pulled low. The EN pin can be driven either by 5-V logic or open-collector gate, normally several microamperes, and the EN pin current, typically 3 μA . If unused, the EN pin must be connected to the IN pin. The device is in the low-power shutdown state if the EN pin is not connected. |
| 6 | GND | — | Ground. |

6 Specifications

6.1 Absolute Maximum Ratings

 over operating free-air temperature range (unless otherwise noted)⁽¹⁾

| | | MIN | MAX | UNIT |
|-------------|---|------------|-----|------|
| V_{IN} | Input voltage | | | V |
| | IN | -20 | 20 | |
| | OUT | -20 | 20 | |
| | Input-to-output differential ⁽²⁾ | -20 | 20 | |
| | FB | -7 | 7 | |
| | EN | -20 | 20 | |
| t_{short} | Output short-circuit duration | Indefinite | | |
| T_J | Operating virtual-junction temperature | -55 | 150 | °C |
| T_{stg} | Storage temperature | -65 | 150 | °C |

- (1) Stresses beyond those listed under *Absolute Maximum Ratings* may cause permanent damage to the device. These are stress ratings only, and functional operation of the device at these or any other conditions beyond those indicated under *Recommended Operating Conditions* is not implied. Exposure to absolute-maximum-rated conditions for extended periods may affect device reliability.
- (2) Absolute maximum input-to-output differential voltage cannot be achieved with all combinations of rated IN pin and OUT pin voltages. With the IN pin at 20 V, the OUT pin may not be pulled below 0 V. The total measured voltage from IN to OUT cannot exceed ± 20 V.

6.2 ESD Ratings

| | | VALUE | UNIT |
|-------------|--|-------|------|
| $V_{(ESD)}$ | Electrostatic discharge | | V |
| | Human-body model (HBM), per ANSI/ESDA/JEDEC JS-001, all pins ⁽¹⁾ | 2000 | |
| | Charged-device model (CDM), per JEDEC specification JESD22-C101, all pins ⁽²⁾ | 1000 | |

- (1) JEDEC document JEP155 states that 500-V HBM allows safe manufacturing with a standard ESD control process.
- (2) JEDEC document JEP157 states that 250-V CDM allows safe manufacturing with a standard ESD control process.

6.3 Recommended Operating Conditions

over operating free-air temperature range (unless otherwise noted)

| | | MIN | MAX | UNIT |
|----------|--|--------------------|------|------|
| V_{IN} | Input voltage | $V_{OUT} + V_{DO}$ | 20 | V |
| V_{IH} | EN high-level input voltage | 2 | 20 | V |
| V_{IL} | EN low-level input voltage | | 0.25 | V |
| T_J | Recommended operating junction temperature | -55 | 125 | °C |

6.4 Thermal Information

| THERMAL METRIC ⁽¹⁾ | | TPS73801-SEP | UNIT |
|-------------------------------|--|---------------|------|
| | | DCQ (SOT-223) | |
| | | 6 PINS | |
| $R_{\theta JA}$ | Junction-to-ambient thermal resistance | 50.5 | °C/W |
| $R_{\theta JC(top)}$ | Junction-to-case (top) thermal resistance | 31.1 | °C/W |
| $R_{\theta JB}$ | Junction-to-board thermal resistance | 5.1 | °C/W |
| Ψ_{JT} | Junction-to-top characterization parameter | 1 | °C/W |
| Ψ_{JB} | Junction-to-board characterization parameter | 5 | °C/W |
| $R_{\theta JC(bot)}$ | Junction-to-case (bottom) thermal resistance | — | °C/W |

- (1) For more information about traditional and new thermal metrics, see the *Semiconductor and IC Package Thermal Metrics* application report, [SPRA953](#).

6.5 Electrical Characteristics

Over operating temperature range $T_A = -55^\circ\text{C}$ to 125°C (unless otherwise noted)

| PARAMETER | | TEST CONDITIONS | T_J | MIN | TYP ⁽¹⁾ | MAX | UNIT |
|-----------|--|--|------------|-------|--------------------|-------|---------------------|
| V_{IN} | Input voltage ⁽²⁾⁽³⁾ | | 25°C | 2.2 | 1.9 | 20 | V |
| V_{FB} | FB pin voltage ⁽²⁾⁽⁴⁾ | $V_{IN} = 2.21\text{ V}$, $I_{LOAD} = 1\text{ mA}$ | 25°C | 1.192 | 1.21 | 1.228 | V |
| | | $V_{IN} = 2.5\text{ V to }20\text{ V}$, $I_{LOAD} = 1\text{ mA to }1\text{ A}$ | Full range | 1.174 | 1.21 | 1.246 | |
| | Line regulation ⁽²⁾ | $\Delta V_{IN} = 2.21\text{ V to }20\text{ V}$, $I_{LOAD} = 1\text{ mA}$ | Full range | | 1.5 | 5 | mV |
| | Load regulation ⁽²⁾ | $V_{IN} = 2.5\text{ V}$, $\Delta I_{LOAD} = 1\text{ mA to }1\text{ A}$ | 25°C | | 2 | 8 | mV |
| | | | Full range | | | 18 | |
| V_{DO} | Dropout voltage ⁽³⁾⁽⁵⁾⁽⁶⁾ $V_{IN} = V_{OUT(NOMINAL)}$ | $I_{LOAD} = 1\text{ mA}$ | 25°C | | 0.02 | 0.06 | V |
| | | | Full range | | | 0.10 | |
| | | $I_{LOAD} = 100\text{ mA}$ | 25°C | | 0.1 | 0.17 | |
| | | | Full range | | | 0.22 | |
| | | $I_{LOAD} = 500\text{ mA}$ | 25°C | | 0.19 | 0.27 | |
| | | | Full range | | | 0.35 | |
| | | $I_{LOAD} = 1\text{ A}$ | 25°C | | 0.24 | 0.30 | |
| | | | Full range | | | 0.40 | |
| I_{GND} | GND pin current ⁽⁶⁾⁽⁷⁾ $V_{IN} = V_{OUT(NOMINAL)} + 1$ | $I_{LOAD} = 0\text{ mA}$ | Full range | | 1 | 1.5 | mA |
| | | $I_{LOAD} = 1\text{ mA}$ | Full range | | 1.1 | 1.6 | |
| | | $I_{LOAD} = 100\text{ mA}$ | Full range | | 3.8 | 5.5 | |
| | | $I_{LOAD} = 500\text{ mA}$ | Full range | | 15 | 25 | |
| | | $I_{LOAD} = 1\text{ A}$ | Full range | | 35 | 80 | |
| V_N | Output voltage noise | $C_{OUT} = 10\text{ }\mu\text{F}$, $I_{LOAD} = 1\text{ A}$, $B_W = 10\text{ Hz to }100\text{ kHz}$ | 25°C | | 45 | | μV_{RMS} |
| I_{FB} | FB pin bias current ⁽²⁾⁽⁸⁾ | | 25°C | | 3 | 10 | μA |
| V_{EN} | Shutdown threshold | $V_{OUT} = \text{OFF to ON}$ | Full range | | 0.9 | 2 | V |
| | | $V_{OUT} = \text{ON to OFF}$ | Full range | 0.15 | 0.75 | | |
| I_{EN} | $\overline{\text{EN}}$ pin current | $V_{EN} = 0\text{ V}$ | 25°C | | 0.01 | 1 | μA |
| | | $V_{EN} = 20\text{ V}$ | 25°C | | 3 | 30 | |
| | Quiescent current in shutdown | $V_{IN} = 6\text{ V}$, $V_{EN} = 0\text{ V}$ | 25°C | | 0.01 | 1 | μA |
| PSRR | Ripple rejection ⁽⁹⁾ | $V_{IN} - V_{OUT} = 1.5\text{ V (avg)}$, $V_{RIPPLE} = 0.5\text{ V}_{P-P}$, $f_{RIPPLE} = 120\text{ Hz}$, $I_{LOAD} = 0.75\text{ A}$ | 25°C | 55 | 63 | | dB |
| I_{CL} | Current limit | $V_{IN} = 7\text{ V}$, $V_{OUT} = 0\text{ V}$ | 25°C | | 2 | | A |
| | | $V_{IN} = V_{OUT(NOMINAL)} + 1$ | Full range | | 1.6 | | |
| I_{REV} | Input reverse leakage current | $V_{IN} = -20\text{ V}$, $V_{OUT} = 0\text{ V}$ | Full range | | | 1 | mA |
| I_{RO} | Reverse output current ⁽¹⁰⁾ | $V_{OUT} = 1.21\text{ V}$, $V_{IN} < 1.21\text{ V}$ | 25°C | | 300 | 600 | μA |

- (1) Typical values represent the likely parametric nominal values determined at the time of characterization. Typical values depend on the application and configuration and may vary over time. Typical values are not ensured on production material.
- (2) The TPS73801-SEP is tested and specified for these conditions with the FB pin connected to the OUT pin.
- (3) Dropout voltages are limited by the minimum input voltage specification under some output voltage/load conditions.
- (4) Operating conditions are limited by maximum junction temperature. The regulated output voltage specification does not apply for all possible combinations of input voltage and output current. When operating at maximum input voltage, the output current range must be limited. When operating at maximum output current, the input voltage range must be limited.
- (5) Dropout voltage is the minimum input to output voltage differential needed to maintain regulation at a specified output current. In dropout, the output voltage is equal to: $V_{IN} - V_{DROPOUT}$.
- (6) To satisfy requirements for minimum input voltage, the TPS73801-SEP is tested and specified for these conditions with an external resistor divider (two 4.12-k Ω resistors) for an output voltage of 2.4 V. The external resistor divider adds a 300-mA DC load on the output.
- (7) GND pin current is tested with $V_{IN} = (V_{OUT(NOMINAL)} + 1\text{ V})$ and a current source load. The GND pin current decreases at higher input voltages.
- (8) FB pin bias current flows into the FB pin.
- (9) Parameter is specified by characterization and is not tested in production.
- (10) Reverse output current is tested with the IN pin grounded and the OUT pin forced to the rated output voltage. This current flows into the OUT pin and out the GND pin.

6.6 Typical Characteristics

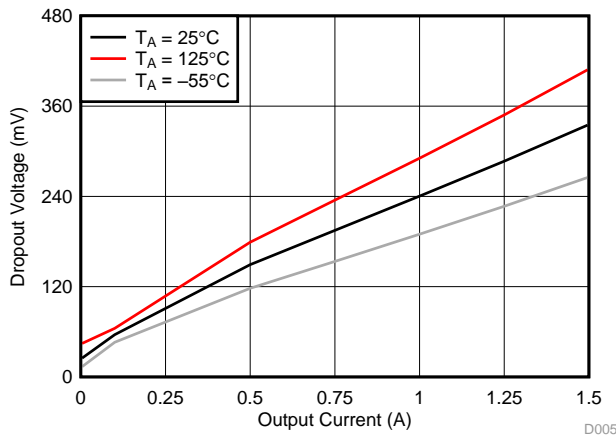

Figure 1. Dropout Voltage vs Output Current

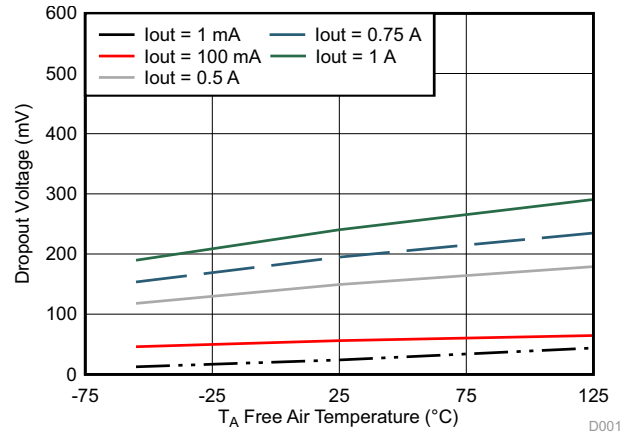
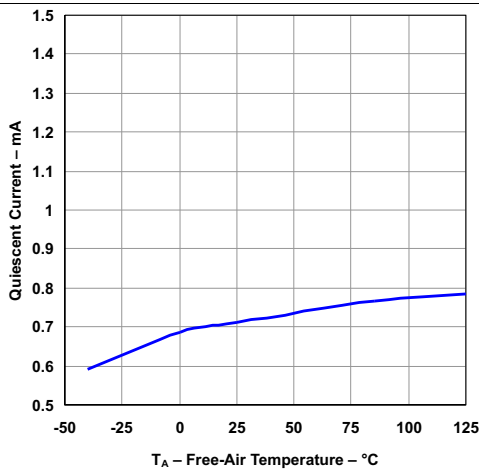
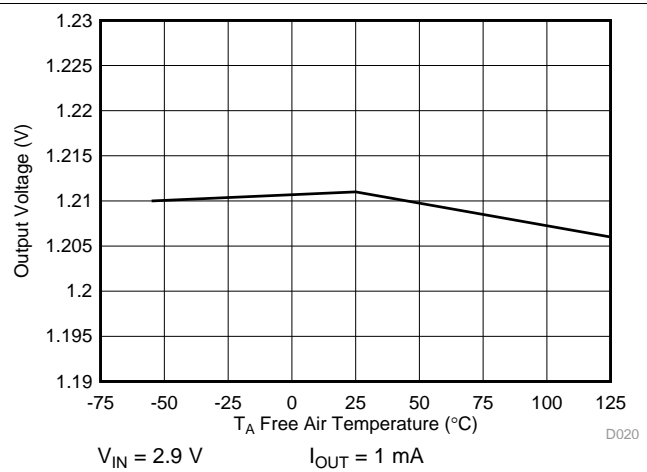

Figure 2. Dropout Voltage vs Temperature



$V_{IN} = 6\text{ V}$
 $V_{EN} = V_{IN}$
 $I_{OUT} = 0\text{ A}$

Figure 3. Quiescent Current vs Temperature



$V_{IN} = 2.9\text{ V}$
 $I_{OUT} = 1\text{ mA}$

Figure 4. Output Voltage vs Temperature

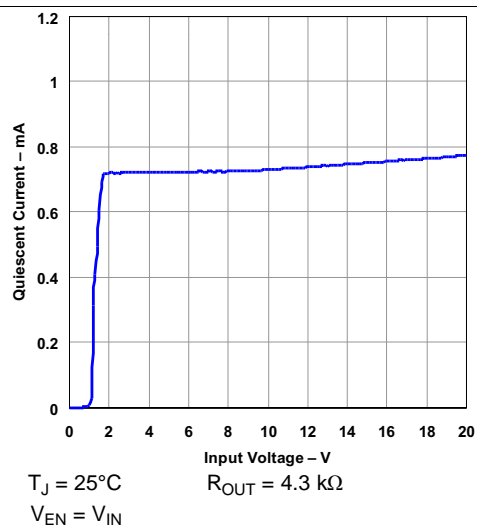

$T_J = 25^\circ\text{C}$
 $V_{EN} = V_{IN}$
 $R_{OUT} = 4.3\text{ k}\Omega$

Figure 5. Quiescent Current vs Input Voltage

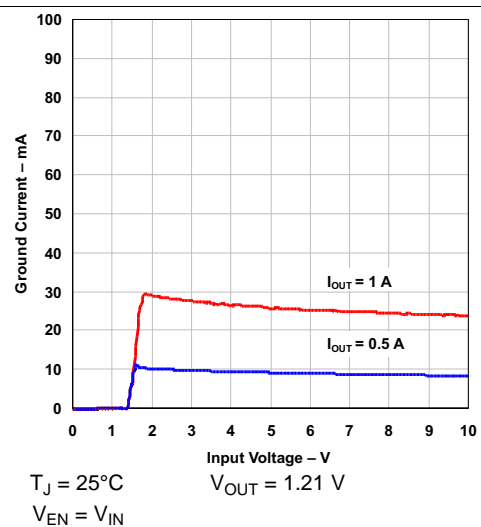

$T_J = 25^\circ\text{C}$
 $V_{EN} = V_{IN}$
 $V_{OUT} = 1.21\text{ V}$

Figure 6. Ground Current vs Input Voltage

Typical Characteristics (continued)

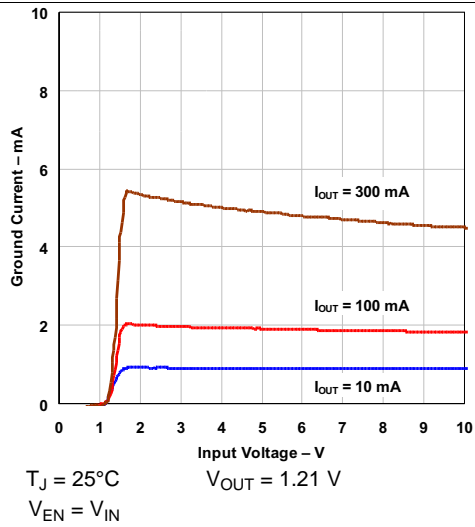

Figure 7. Ground Current vs Input Voltage

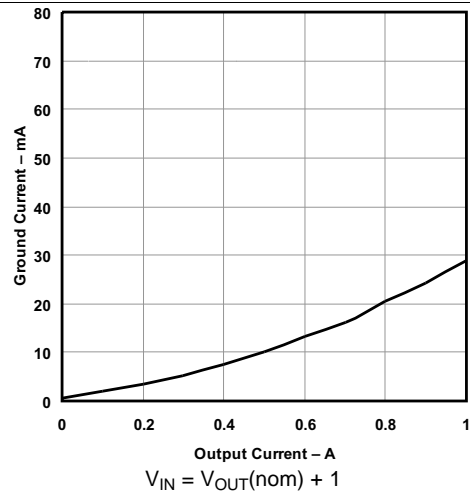

Figure 8. Ground Current vs Output Current

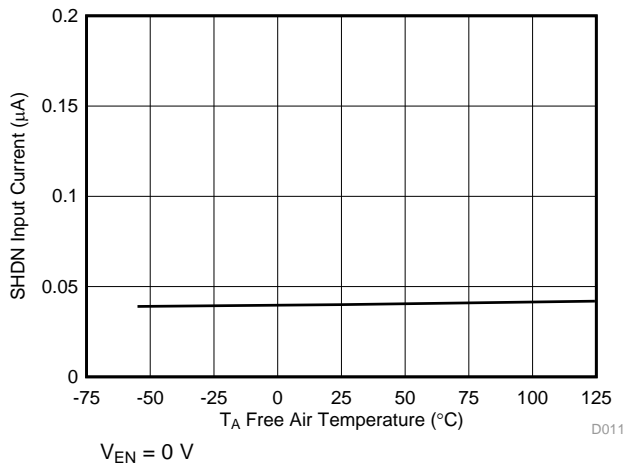

Figure 9. EN Input Current vs Temperature

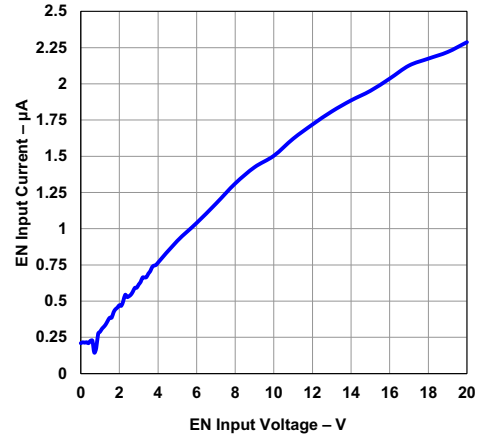

Figure 10. EN Input Current vs EN Input Voltage

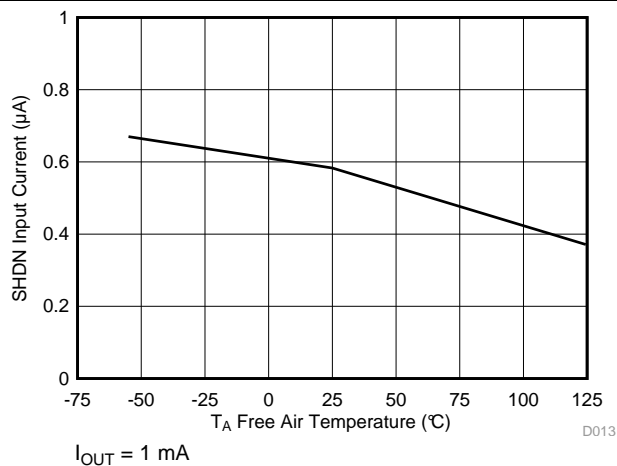

Figure 11. EN Threshold (Off to On) vs Temperature

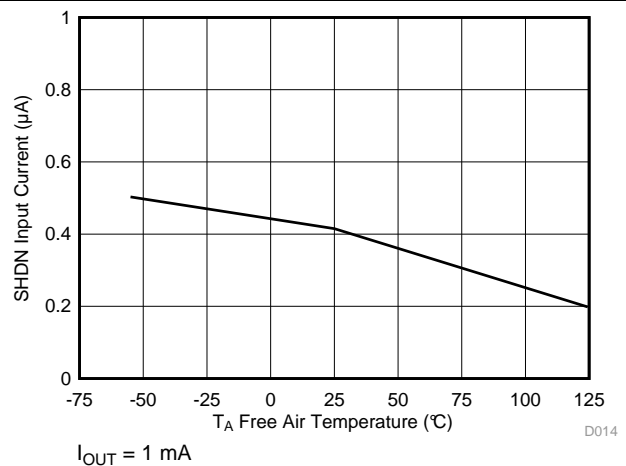

Figure 12. EN Threshold (On to Off) vs Temperature

Typical Characteristics (continued)

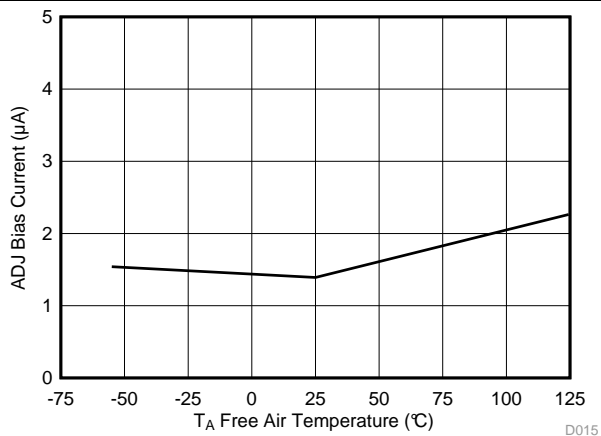

Figure 13. FB Bias Current vs Temperature

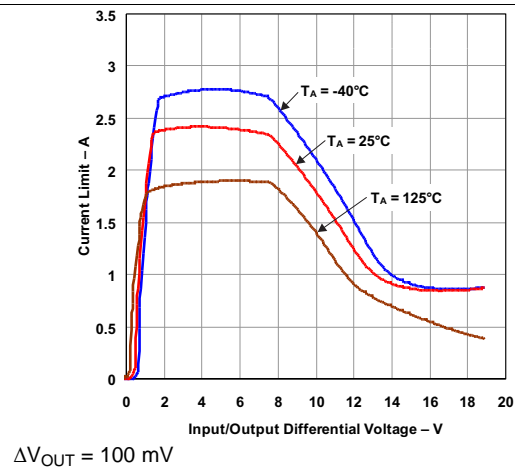

Figure 14. Current Limit vs Input/Output Differential Voltage

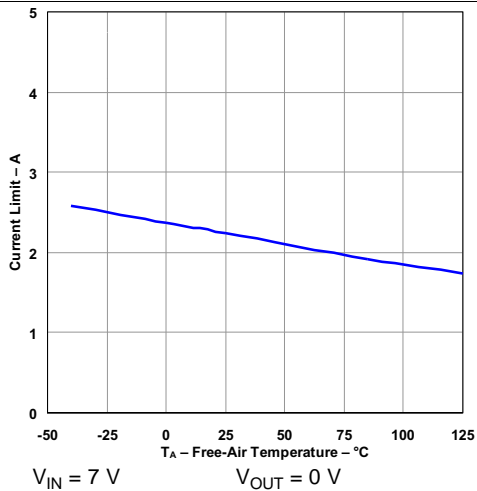

Figure 15. Current Limit vs Temperature

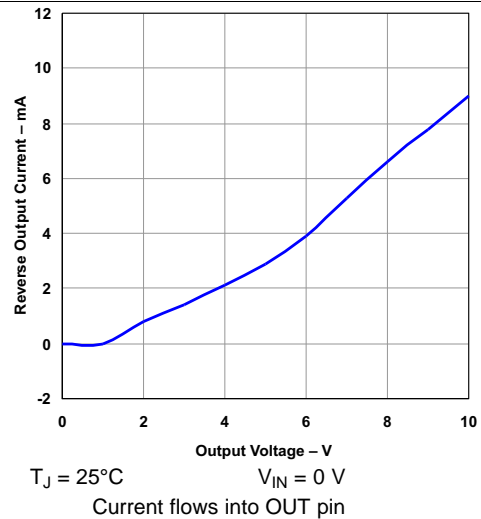

Figure 16. Reverse Output Current vs Output Voltage

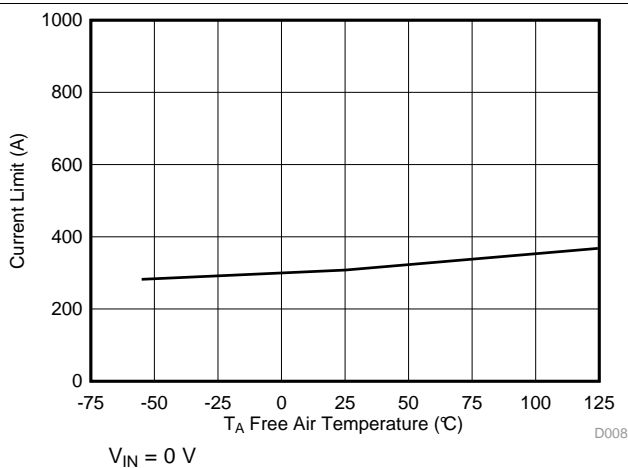

Figure 17. Reverse Output Current vs Temperature

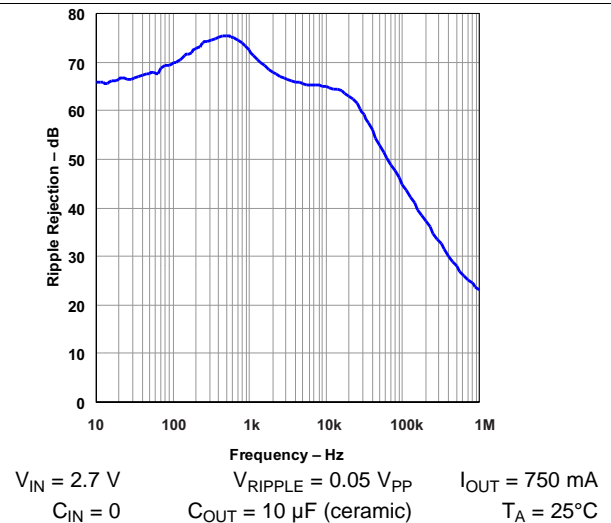

Figure 18. Ripple Rejection vs Frequency

Typical Characteristics (continued)

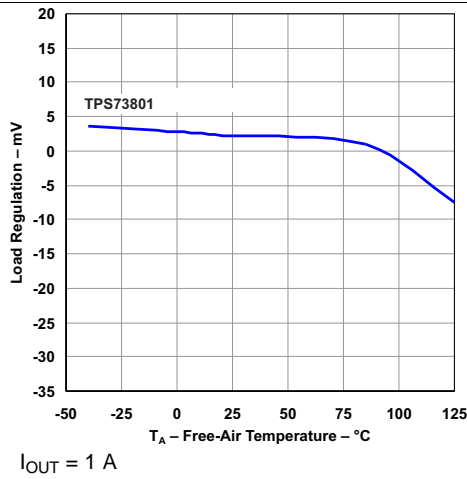

Figure 19. Load Regulation vs Temperature

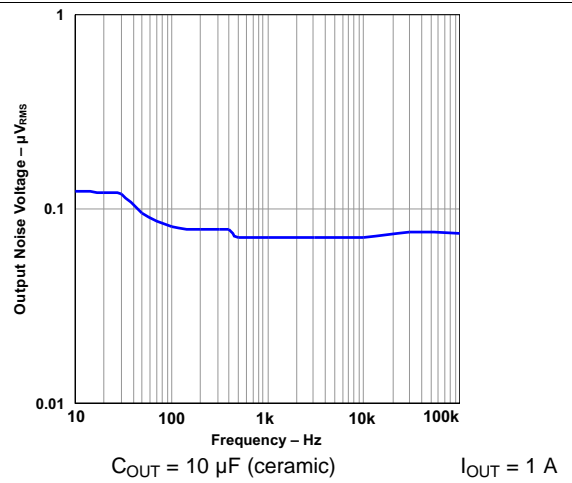

Figure 20. Output Noise Voltage vs Frequency

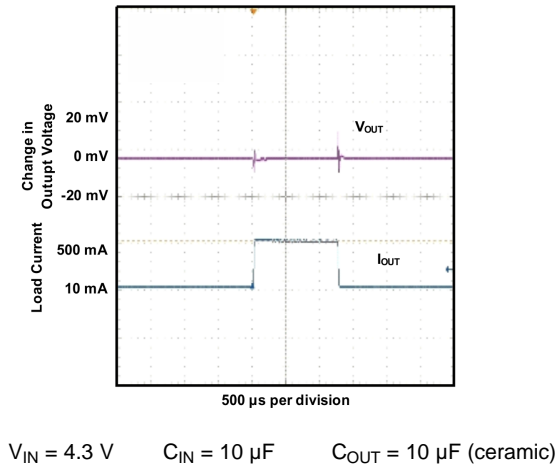

Figure 21. Load Transient Response

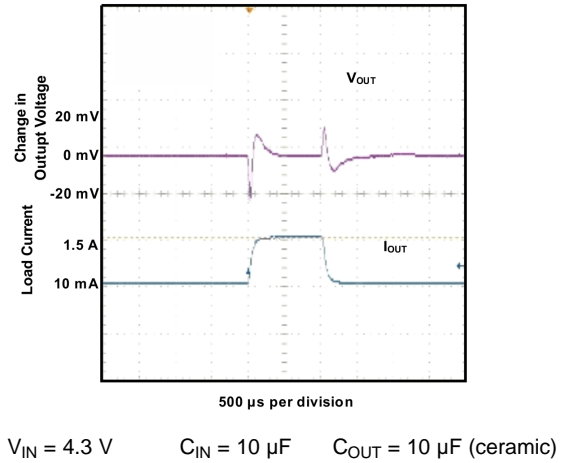

Figure 22. Max Load Transient Response

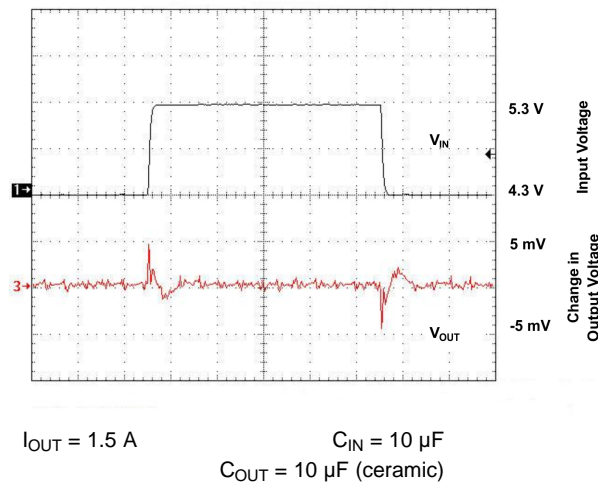

Figure 23. Line Transient Response

7 Detailed Description

7.1 Overview

The TPS73801-SEP is a 1-A LDO regulator optimized for fast transient response. The devices are capable of supplying 1 A at a dropout voltage of 300 mV. The low operating quiescent current (1 mA) drops to less than 1 μ A in shutdown. In addition to the low quiescent current, the TPS73801-SEP regulators incorporate several protection features which make them ideal for use in battery-powered systems. The devices are protected against both reverse input and reverse output voltages. In battery-backup applications where the output can be held up by a backup battery when the input is pulled to ground, the TPS73801-SEP acts as if it has a diode in series with its output and prevents reverse current flow. Additionally, in dual-supply applications where the regulator load is returned to a negative supply, the output can be pulled below ground by as much as 20 V and still allow the device to start and operate.

7.2 Functional Block Diagram

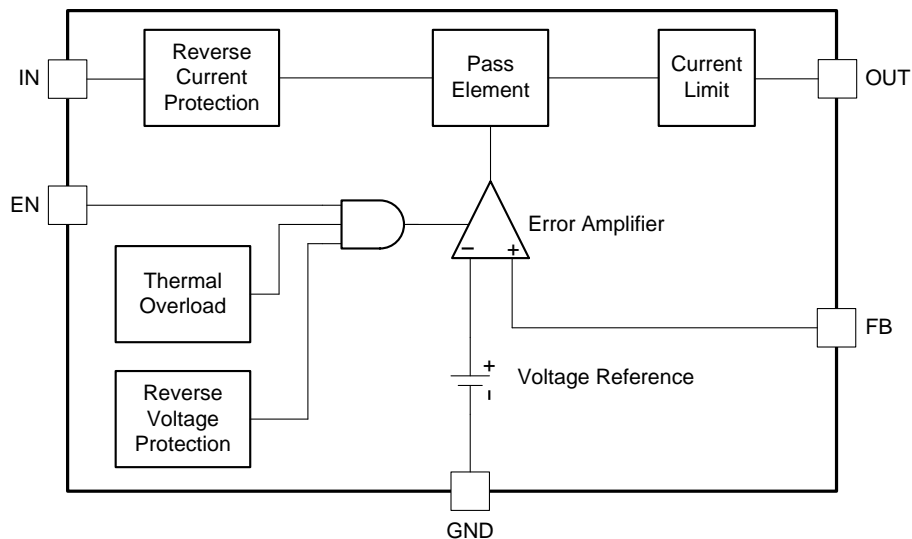

7.3 Feature Description

7.3.1 Adjustable Operation

The TPS73801-SEP has an adjustable output voltage range of 1.21 V to 20 V. The output voltage is set by the ratio of two external resistors as shown in Figure 24. The device maintains the voltage at the FB pin at 1.21 V referenced to ground. The current in R1 is then equal to $(1.21 \text{ V} / R1)$, and the current in R2 is the current in R1 plus the FB pin bias current. The FB pin bias current, 3 μ A at 25°C, flows through R2 into the FB pin. The output voltage can be calculated using the formula shown in Equation 1. The value of R1 should be less than 4.17 k Ω to minimize errors in the output voltage caused by the FB pin bias current. Note that in shutdown the output is turned off, and the divider current is zero.

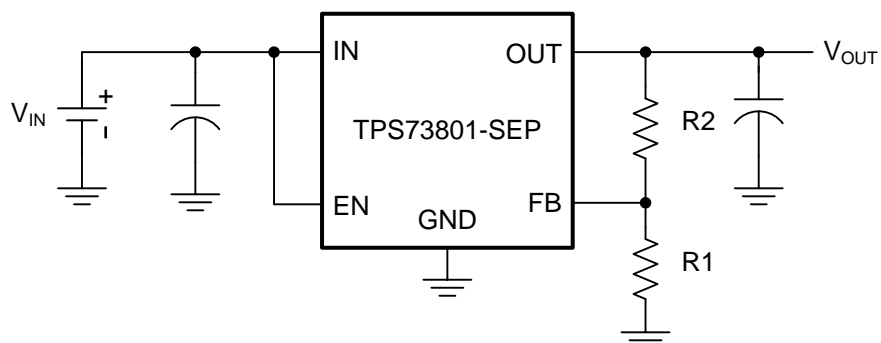

Figure 24. Adjustable Operation

The output voltage can be set using the following equations:

$$V_{OUT} = 1.21 V \left(1 + \frac{R_2}{R_1}\right) + I_{FB} \times R_2 \quad (1)$$

$$V_{FB} = 1.21 V \quad (2)$$

$$I_{FB} = 3 \mu A \text{ at } 25^\circ C \quad (3)$$

$$\text{Output Range} = 1.21 \text{ to } 20 V \quad (4)$$

7.3.2 Fixed Operation

The TPS73801-SEP can be used in a fixed voltage configuration. By connecting the FB pin to OUT, the TPS73801-SEP will regulate the output to 1.21 V. During fixed voltage operation, the FB pin can be used for a Kelvin connection if routed separately to the load. This allows the regulator to compensate for voltage drop across parasitic resistances (R_P) between the output and the load. This becomes more crucial with higher load currents.

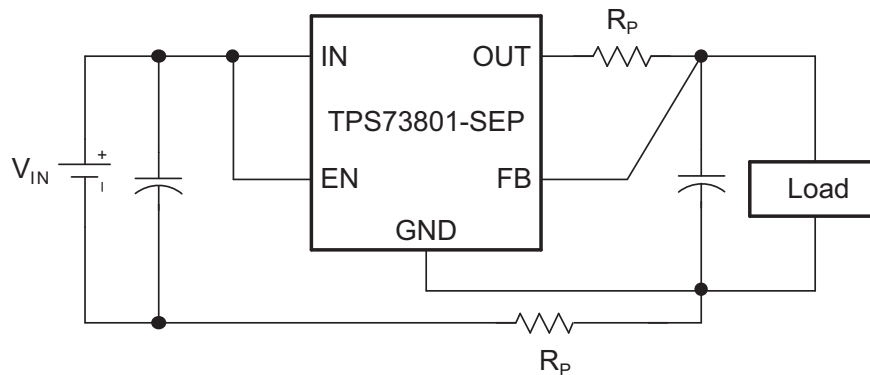

Figure 25. Kelvin Sense Connection

7.3.3 Overload Recovery

Like many IC power regulators, the TPS73801-SEP has safe operating area protection. The safe area protection decreases the current limit as input-to-output voltage increases and keeps the power transistor inside a safe operating region for all values of input-to-output voltage. The protection is designed to provide some output current at all values of input-to-output voltage up to the device breakdown.

When power is first turned on, as the input voltage rises, the output follows the input, allowing the regulator to start up into very heavy loads. During start up, as the input voltage is rising, the input-to-output voltage differential is small, allowing the regulator to supply large output currents. With a high input voltage, a problem can occur wherein removal of an output short does not allow the output voltage to recover. Other regulators also exhibit this phenomenon, so it is not unique to the TPS73801-SEP.

The problem occurs with a heavy output load when the input voltage is high and the output voltage is low. Common situations occur immediately after the removal of a short circuit or when the shutdown pin is pulled high after the input voltage has already been turned on. The load line for such a load may intersect the output current curve at two points. If this happens, there are two stable output operating points for the regulator. With this double intersection, the input power supply may need to be cycled down to zero and brought up again to make the output recover.

7.3.4 Output Voltage Noise

The TPS73801-SEP regulators have been designed to provide low output voltage noise over the 10-Hz to 100-kHz bandwidth while operating at full load. Output voltage noise is typically 40 nV/ \sqrt{Hz} over this frequency bandwidth for the TPS73801-SEP. For higher output voltages (generated by using a resistor divider), the output voltage noise is gained up accordingly. This results in RMS noise over the 10-Hz to 100-kHz bandwidth of 14 μV_{RMS} for the TPS73801-SEP.

Higher values of output voltage noise may be measured when care is not exercised with regards to circuit layout and testing. Crosstalk from nearby traces can induce unwanted noise onto the output of the TPS73801-SEP. Power supply ripple rejection must also be considered; the TPS73801-SEP regulators do not have unlimited power-supply rejection and pass a small portion of the input noise through to the output.

7.3.5 Protection Features

The TPS73801-SEP regulators incorporate several protection features that make them ideal for use in battery-powered circuits. In addition to the normal protection features associated with monolithic regulators, such as current limiting and thermal limiting, the devices are protected against reverse input voltages, reverse output voltages, and reverse voltages from output to input.

Current limit protection and thermal overload protection are intended to protect the device against current overload conditions at the output of the device. For normal operation, the junction temperature should not exceed 125°C.

The input of the device withstands reverse voltages of 20 V. Current flow into the device is limited to less than 1 mA (typically less than 100 µA), and no negative voltage appears at the output. The device protects both itself and the load. This provides protection against batteries that can be plugged in backward.

The output of the TPS73801-SEP can be pulled below ground without damaging the device. If the input is left open circuit or grounded, the output can be pulled below ground by 20 V. The output acts like an open circuit; no current flows out of the pin. If the input is powered by a voltage source, the output sources the short-circuit current of the device and protects itself by thermal limiting. In this case, grounding the EN pin turns off the device and stops the output from sourcing the short-circuit current.

The FB pin can be pulled above or below ground by as much as 7 V without damaging the device. If the input is left open circuit or grounded, the FB pin acts like an open circuit when pulled below ground and like a large resistor (typically 5 kΩ) in series with a diode when pulled above ground.

In situations where the FB pin is connected to a resistor divider that would pull the FB pin above its 7-V clamp voltage if the output is pulled high, the FB pin input current must be limited to less than 5 mA. For example, a resistor divider is used to provide a regulated 1.5-V output from the 1.21-V reference when the output is forced to 20 V. The top resistor of the resistor divider must be chosen to limit the current into the FB pin to less than 5 mA when the FB pin is at 7 V. The 13-V difference between OUT and FB pins divided by the 5-mA maximum current into the FB pin yields a minimum top resistor value of 2.6 kΩ.

In circuits where a backup battery is required, several different input/output conditions can occur. The output voltage may be held up while the input is either pulled to ground, pulled to some intermediate voltage, or is left open circuit. When the IN pin of the TPS73801-SEP is forced below the OUT pin or the OUT pin is pulled above the IN pin, input current typically drops to less than 2 µA. This can happen if the input of the device is connected to a discharged (low voltage) battery and the output is held up by either a backup battery or a second regulator circuit. The state of the EN pin has no effect on the reverse output current when the output is pulled above the input.

7.4 Device Functional Modes

See the device modes in [Table 1](#).

Table 1. Device Modes

| EN | DEVICE STATE |
|----|-------------------|
| H | Regulated voltage |
| L | Shutdown |

8 Application and Implementation

NOTE

Information in the following applications sections is not part of the TI component specification, and TI does not warrant its accuracy or completeness. TI's customers are responsible for determining suitability of components for their purposes. Customers should validate and test their design implementation to confirm system functionality.

8.1 Application Information

8.1.1 Output Capacitance and Transient Response

The TPS73801-SEP regulators are designed to be stable with a wide range of output capacitors. The ESR of the output capacitor affects stability, most notably with small capacitors. A minimum output capacitor of 10 μF with an ESR of 3 Ω or less is recommended to prevent oscillations. Larger values of output capacitance can decrease the peak deviations and provide improved transient response for larger load current changes. Bypass capacitors, used to decouple individual components powered by the TPS73801-SEP, increase the effective output capacitor value.

Extra consideration must be given to the use of ceramic capacitors. Ceramic capacitors are manufactured with a variety of dielectrics, each with different behavior over temperature and applied voltage. The most common dielectrics used are Z5U, Y5V, X5R and X7R. The Z5U and Y5V dielectrics are good for providing high capacitances in a small package, but exhibit strong voltage and temperature coefficients. When used with a 5-V regulator, a 10- μF Y5V capacitor can exhibit an effective value as low as 1 μF to 2 μF over the operating temperature range. The X5R and X7R dielectrics result in more stable characteristics and are more suitable for use as the output capacitor. The X7R type has better stability across temperature, while the X5R is less expensive and is available in higher values.

Voltage and temperature coefficients are not the only sources of problems. Some ceramic capacitors have a piezoelectric response. A piezoelectric device generates voltage across its terminals due to mechanical stress, similar to the way a piezoelectric accelerometer or microphone works. For a ceramic capacitor, the stress can be induced by vibrations in the system or thermal transients.

8.2 Typical Application

This section will highlight some of the design considerations when implementing this device in various applications.

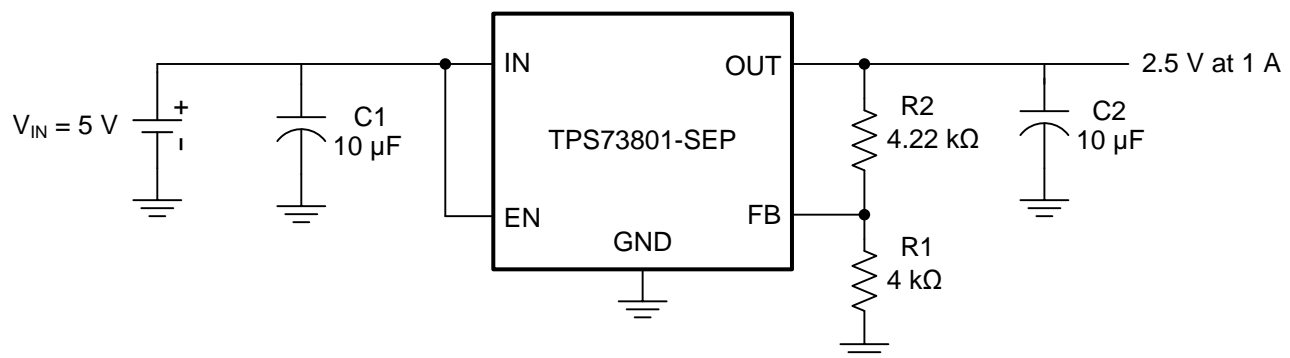

NOTE: All capacitors are ceramic.

Figure 26. Adjustable Output Voltage Operation

Typical Application (continued)

8.2.1 Design Requirements

Table 2 shows the design parameters for this application.

Table 2. Design Parameters

| DESIGN PARAMETER | EXAMPLE VALUE |
|------------------------------|---------------|
| Input voltage (V_{IN}) | 5 V |
| Output voltage (V_{OUT}) | 2.5 V |
| Output current (I_{OUT}) | 0 to 1 A |
| Load regulation | 1% |

8.2.2 Detailed Design Procedure

The TPS73801-SEP has an adjustable output voltage range of 1.21 to 20 V. The output voltage is set by the ratio of two external resistors R1 and R2 as shown in Figure 26. The device maintains the voltage at the FB pin at 1.21 V referenced to ground. The current in R1 is then equal to $(1.21 \text{ V} / R1)$, and the current in R2 is the current in R1 plus the FB pin bias current. The FB pin bias current, 3 μA at 25°C, flows through R2 into the FB pin. The output voltage can be calculated using Equation 5.

$$V_{OUT} = 1.21 \text{ V} \left(1 + \frac{R2}{R1}\right) + I_{FB} \times R2 \quad (5)$$

The value of R1 should be less than 4.17 k Ω to minimize errors in the output voltage caused by the FB pin bias current. Note that in shutdown the output is turned off, and the divider current is zero. For an output voltage of 2.50 V, R1 will be set to 4.0 k Ω . R2 is then found to be 4.22 k Ω using the equation above.

$$V_{OUT} = 1.21 \text{ V} \left(1 + \frac{4.22 \text{ k}\Omega}{4.0 \text{ k}\Omega}\right) + 3 \mu\text{A} \times 4.22 \text{ k}\Omega \quad (6)$$

$$V_{OUT} = 2.50 \text{ V} \quad (7)$$

The adjustable device is tested and specified with the FB pin tied to the OUT pin for an output voltage of 1.21 V. Specifications for output voltages greater than 1.21 V are proportional to the ratio of the desired output voltage to 1.21 V: $V_{OUT} / 1.21 \text{ V}$. For example, load regulation for an output current change of 1 mA to 1.5 A is –2 mV (typ) at $V_{OUT} = 1.21 \text{ V}$. At $V_{OUT} = 2.50 \text{ V}$, the typical load regulation is:

$$(2.50 \text{ V} / 1.21 \text{ V})(-2 \text{ mV}) = -4.13 \text{ mV} \quad (8)$$

Figure 27 shows the actual change in output is about 3 mV for a 1-A load step. The maximum load regulation at 25°C is –8 mV. At $V_{OUT} = 2.50 \text{ V}$, the maximum load regulation is:

$$(2.50 \text{ V} / 1.21 \text{ V})(-8 \text{ mV}) = -16.53 \text{ mV} \quad (9)$$

Since 16.53 mV is only 0.7% of the 2.5 V output voltage, the load regulation will meet the design requirements.

8.2.3 Application Curve

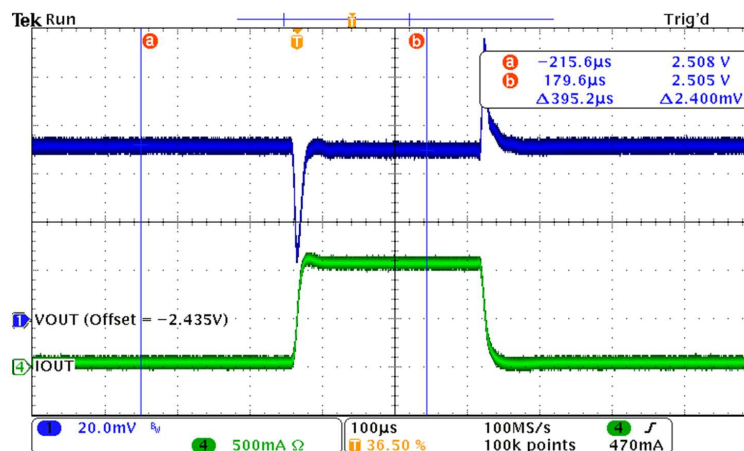

Figure 27. 1-A Load Transient Response

9 Power Supply Recommendations

The device is designed to operate with an input voltage supply up to 20 V. The minimum input voltage should provide adequate headroom greater than the dropout voltage in order for the device to have a regulated output. If the input supply is noisy, additional input capacitors with low ESR can help improve the output noise performance.

10 Layout

10.1 Layout Guidelines

1. For best performance, all traces should be as short as possible.
2. Use wide traces for IN, OUT, and GND to minimize the parasitic electrical effects.
3. A minimum output capacitor of 10 μF with an ESR of 3 Ω or less is recommended to prevent oscillations. X5R and X7R dielectrics are preferred.
4. Place the Output Capacitor as close as possible to the OUT pin of the device.
5. The tab of the DCQ package should be connected to ground.

10.2 Layout Example

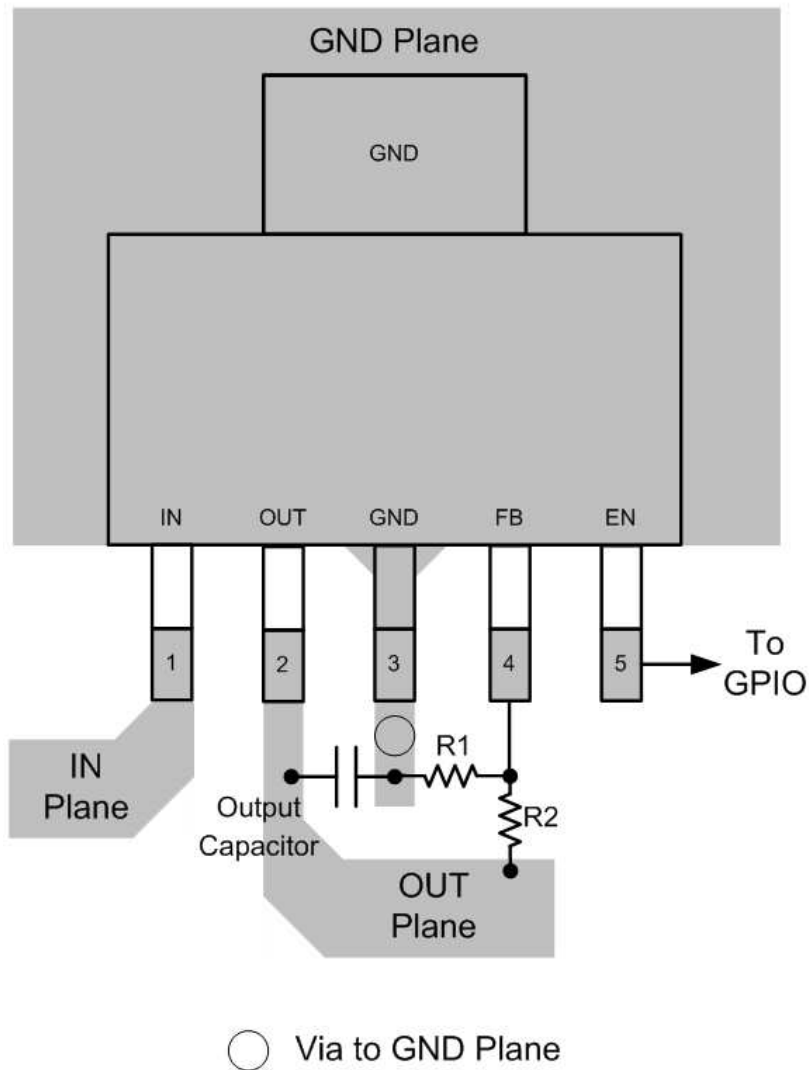

Figure 28. SOT-223 Layout Example (DCQ)

10.3 Thermal Considerations

The power handling capability of the device is limited by the recommended maximum operating junction temperature (125°C). The power dissipated by the device is made up of two components:

1. Output current multiplied by the input/output voltage differential: $I_{OUT}(V_{IN} - V_{OUT})$
2. GND pin current multiplied by the input voltage: $I_{GND} \times V_{IN}$

The GND pin current can be found using the GND Pin Current graphs in [Typical Characteristics](#) section. Power dissipation is equal to the sum of the two components listed above.

The TPS73801-SEP series regulators have internal thermal limiting designed to protect the device during overload conditions. For continuous normal conditions, the recommended maximum operating junction temperature is 125°C. It is important to give careful consideration to all sources of thermal resistance from junction to ambient. Additional heat sources mounted nearby must also be considered.

10.3.1 Calculating Junction Temperature

Example: Given an output voltage of 3.3 V, an input voltage range of 4 V to 6 V, an output current range of 0 mA to 500 mA, and a maximum ambient temperature of 50°C, what is the operating junction temperature?

The power dissipated by the device is equal to:

$$I_{OUT(MAX)}(V_{IN(MAX)} - V_{OUT}) + I_{GND}(V_{IN(MAX)})$$

where

- $I_{OUT(MAX)} = 500 \text{ mA}$
- $V_{IN(MAX)} = 6 \text{ V}$
- I_{GND} at ($I_{OUT} = 500 \text{ mA}$, $V_{IN} = 6 \text{ V}$) = 10 mA (10)

So,

$$P = 500 \text{ mA} \times (6 \text{ V} - 3.3 \text{ V}) + 10 \text{ mA} \times 6 \text{ V} = 1.41 \text{ W} \quad (11)$$

The thermal resistance of the DCQ package is 50.5°C/W. So the junction temperature rise above ambient is approximately equal to:

$$1.41 \text{ W} \times 50.5^\circ\text{C/W} = 71.2^\circ\text{C} \quad (12)$$

The junction temperature rise can then be added to the maximum ambient temperature to find the operating junction temperature (T_J):

$$T_J = 50^\circ\text{C} + 71.2^\circ\text{C} = 121.2^\circ\text{C} \quad (13)$$

11 器件和文档支持

11.1 接收文档更新通知

要接收文档更新通知，请导航至 TI.com.cn 上的器件产品文件夹。单击右上角的 [通知我](#) 进行注册，即可每周接收产品信息更改摘要。有关更改的详细信息，请查看任何已修订文档中包含的修订历史记录。

11.2 社区资源

下列链接提供到 TI 社区资源的连接。链接的内容由各个分销商“按照原样”提供。这些内容并不构成 TI 技术规范，并且不一定反映 TI 的观点；请参阅 TI 的 [《使用条款》](#)。

TI E2E™ 在线社区 [TI 的工程师对工程师 \(E2E\) 社区](#)。此社区的创建目的在于促进工程师之间的协作。在 e2e.ti.com 中，您可以咨询问题、分享知识、拓展思路并与同行工程师一道帮助解决问题。

设计支持 [TI 参考设计支持](#) 可帮助您快速查找有帮助的 E2E 论坛、设计支持工具以及技术支持的联系信息。

11.3 商标

E2E is a trademark of Texas Instruments.

All other trademarks are the property of their respective owners.

11.4 静电放电警告



ESD 可能会损坏该集成电路。德州仪器 (TI) 建议通过适当的预防措施处理所有集成电路。如果不遵守正确的处理措施和安装程序，可能会损坏集成电路。

ESD 的损坏小至导致微小的性能降级，大至整个器件故障。精密的集成电路可能更容易受到损坏，这是因为非常细微的参数更改都可能会导致器件与其发布的规格不相符。

11.5 术语表

SLYZ022 — *TI 术语表*。

这份术语表列出并解释术语、缩写和定义。

12 机械、封装和可订购信息

以下页面包含机械、封装和可订购信息。这些信息是指定器件的最新可用数据。数据如有变更，恕不另行通知，且不会对此文档进行修订。如需获取此数据表的浏览器版本，请查阅左侧的导航栏。

重要声明和免责声明

TI 均以“原样”提供技术性数据（包括数据表）、设计资源（包括参考设计）、应用或其他设计建议、网络工具、安全信息和其他资源，不保证其中不含任何瑕疵，且不做任何明示或暗示的担保，包括但不限于对适销性、适合某特定用途或不侵犯任何第三方知识产权的暗示担保。

所述资源可供专业开发人员应用TI 产品进行设计使用。您将对以下行为独自承担全部责任：(1) 针对您的应用选择合适的TI 产品；(2) 设计、验证并测试您的应用；(3) 确保您的应用满足相应标准以及任何其他安全、安保或其他要求。所述资源如有变更，恕不另行通知。TI 对您使用所述资源的授权仅限于开发资源所涉及TI 产品的相关应用。除此之外不得复制或展示所述资源，也不提供其它TI 或任何第三方的知识产权授权许可。如因使用所述资源而产生任何索赔、赔偿、成本、损失及债务等，TI 对此概不负责，并且您须赔偿由此对TI 及其代表造成的损害。

TI 所提供产品均受TI 的销售条款 (<http://www.ti.com.cn/zh-cn/legal/termsofsale.html>) 以及ti.com.cn上或随附TI产品提供的其他可适用条款的约束。TI提供所述资源并不扩展或以其他方式更改TI 针对TI 产品所发布的可适用的担保范围或担保免责声明。

邮寄地址：上海市浦东新区世纪大道 1568 号中建大厦 32 楼，邮政编码：200122
Copyright © 2019 德州仪器半导体技术（上海）有限公司

PACKAGING INFORMATION

| Orderable Device | Status (1) | Package Type | Package Drawing | Pins | Package Qty | Eco Plan (2) | Lead/Ball Finish (6) | MSL Peak Temp (3) | Op Temp (°C) | Device Marking (4/5) | Samples |
|-------------------|---------------|--------------|-----------------|------|-------------|-------------------------|-------------------------|----------------------|--------------|-------------------------|-------------------------|
| TPS73801MDCQPSEP | ACTIVE | SOT-223 | DCQ | 6 | 78 | Green (RoHS & no Sb/Br) | CU NIPDAUAG | Level-2-260C-1 YEAR | -55 to 125 | 73801-SP | Samples |
| TPS73801MDCQTPSEP | ACTIVE | SOT-223 | DCQ | 6 | 250 | Green (RoHS & no Sb/Br) | CU NIPDAUAG | Level-2-260C-1 YEAR | -55 to 125 | 73801-SP | Samples |
| V62/18616-01XE | ACTIVE | SOT-223 | DCQ | 6 | 250 | Green (RoHS & no Sb/Br) | CU NIPDAUAG | Level-2-260C-1 YEAR | -55 to 125 | 73801-SP | Samples |
| V62/18616-01XE-T | ACTIVE | SOT-223 | DCQ | 6 | 78 | Green (RoHS & no Sb/Br) | CU NIPDAUAG | Level-2-260C-1 YEAR | -55 to 125 | 73801-SP | Samples |

(1) The marketing status values are defined as follows:

ACTIVE: Product device recommended for new designs.

LIFEBUY: TI has announced that the device will be discontinued, and a lifetime-buy period is in effect.

NRND: Not recommended for new designs. Device is in production to support existing customers, but TI does not recommend using this part in a new design.

PREVIEW: Device has been announced but is not in production. Samples may or may not be available.

OBSOLETE: TI has discontinued the production of the device.

(2) **RoHS:** TI defines "RoHS" to mean semiconductor products that are compliant with the current EU RoHS requirements for all 10 RoHS substances, including the requirement that RoHS substance do not exceed 0.1% by weight in homogeneous materials. Where designed to be soldered at high temperatures, "RoHS" products are suitable for use in specified lead-free processes. TI may reference these types of products as "Pb-Free".

RoHS Exempt: TI defines "RoHS Exempt" to mean products that contain lead but are compliant with EU RoHS pursuant to a specific EU RoHS exemption.

Green: TI defines "Green" to mean the content of Chlorine (Cl) and Bromine (Br) based flame retardants meet JS709B low halogen requirements of <=1000ppm threshold. Antimony trioxide based flame retardants must also meet the <=1000ppm threshold requirement.

(3) MSL, Peak Temp. - The Moisture Sensitivity Level rating according to the JEDEC industry standard classifications, and peak solder temperature.

(4) There may be additional marking, which relates to the logo, the lot trace code information, or the environmental category on the device.

(5) Multiple Device Markings will be inside parentheses. Only one Device Marking contained in parentheses and separated by a "-" will appear on a device. If a line is indented then it is a continuation of the previous line and the two combined represent the entire Device Marking for that device.

(6) Lead/Ball Finish - Orderable Devices may have multiple material finish options. Finish options are separated by a vertical ruled line. Lead/Ball Finish values may wrap to two lines if the finish value exceeds the maximum column width.

Important Information and Disclaimer: The information provided on this page represents TI's knowledge and belief as of the date that it is provided. TI bases its knowledge and belief on information provided by third parties, and makes no representation or warranty as to the accuracy of such information. Efforts are underway to better integrate information from third parties. TI has taken and

continues to take reasonable steps to provide representative and accurate information but may not have conducted destructive testing or chemical analysis on incoming materials and chemicals. TI and TI suppliers consider certain information to be proprietary, and thus CAS numbers and other limited information may not be available for release.

In no event shall TI's liability arising out of such information exceed the total purchase price of the TI part(s) at issue in this document sold by TI to Customer on an annual basis.

DCQ (R-PDSO-G6)

PLASTIC SMALL-OUTLINE

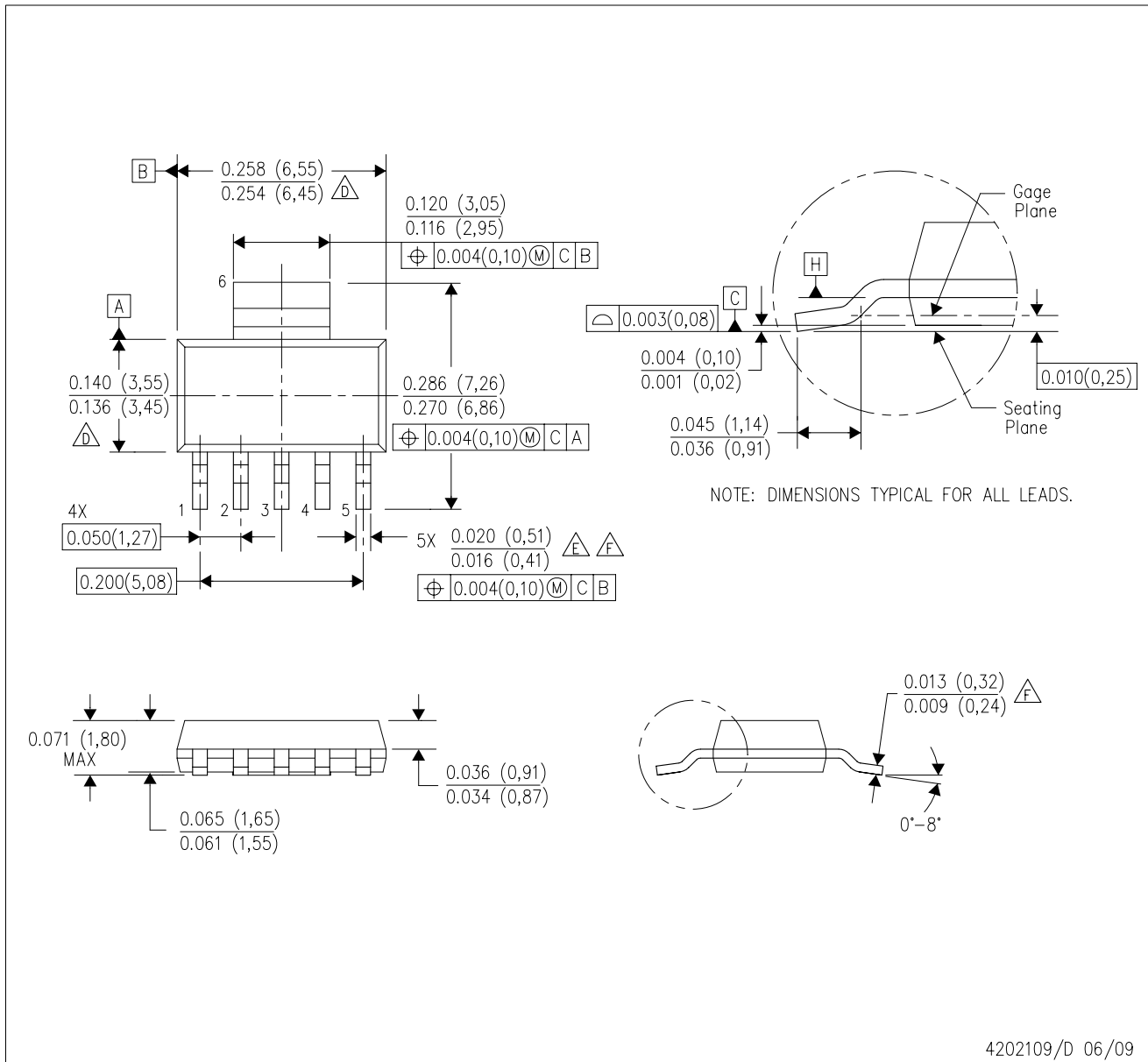

4202109/D 06/09

- NOTES:
- A. All linear dimensions are in inches (millimeters).
 - B. This drawing is subject to change without notice.
 - C. Controlling dimension in inches.
 - $\triangle D$ Body length and width dimensions are determined at the outermost extremes of the plastic body exclusive of mold flash, tie bar burrs, gate burrs, and interlead flash, but including any mismatch between the top and the bottom of the plastic body.
 - $\triangle E$ Lead width dimension does not include dambar protrusion.
 - $\triangle F$ Lead width and thickness dimensions apply to solder plated leads.
 - G. Interlead flash allow 0.008 inch max.
 - H. Gate burr/protrusion max. 0.006 inch.
 - I. Datums A and B are to be determined at Datum H.

重要声明和免责声明

TI 均以“原样”提供技术性数据（包括数据表）、设计资源（包括参考设计）、应用或其他设计建议、网络工具、安全信息和其他资源，不保证其中不含任何瑕疵，且不做任何明示或暗示的担保，包括但不限于对适销性、适合某特定用途或不侵犯任何第三方知识产权的暗示担保。

所述资源可供专业开发人员应用TI 产品进行设计使用。您将对以下行为独自承担全部责任：(1) 针对您的应用选择合适的TI 产品；(2) 设计、验证并测试您的应用；(3) 确保您的应用满足相应标准以及任何其他安全、安保或其他要求。所述资源如有变更，恕不另行通知。TI 对您使用所述资源的授权仅限于开发资源所涉及TI 产品的相关应用。除此之外不得复制或展示所述资源，也不提供其它TI 或任何第三方的知识产权授权许可。如因使用所述资源而产生任何索赔、赔偿、成本、损失及债务等，TI 对此概不负责，并且您须赔偿由此对TI 及其代表造成的损害。

TI 所提供产品均受TI 的销售条款 (<http://www.ti.com.cn/zh-cn/legal/termsofsale.html>) 以及ti.com.cn上或随附TI产品提供的其他可适用条款的约束。TI提供所述资源并不扩展或以其他方式更改TI 针对TI 产品所发布的可适用的担保范围或担保免责声明。

邮寄地址：上海市浦东新区世纪大道 1568 号中建大厦 32 楼，邮政编码：200122
Copyright © 2019 德州仪器半导体技术（上海）有限公司