

# 具有 I<sup>2</sup>C 接口的 TSC2007-Q1 1.2V 至 3.6V、12 位、 纳瓦级功率、4 线微型触摸屏控制器

## 1 特性

- 符合汽车应用 认证
- 具有符合 AEC-Q100 测试指导的以下结果：
  - 器件温度等级 3: 环境工作温度范围为  $-40^{\circ}\text{C}$  至  $85^{\circ}\text{C}$
  - 器件 HBM ESD 分类等级 3B
  - 器件 CDM ESD 分类等级 C6
- 4 线触摸屏接口
- 1.2V 至 3.6V 单电源或基准电压
- 比例换算
- 有效吞吐率：
  - 高达 20kHz (8 位) 或 10kHz (12 位)
- 通过预处理减少总线活动
- I<sup>2</sup>C 接口支持：
  - 标准、快速和高速模式
- 基于命令的简单用户界面：
  - 与 TSC2003-Q1 兼容
  - 8 位或 12 位分辨率
- 片上温度测量
- 触摸压力测量
- 屏幕触摸内部检测
- 用于笔触式检测或数据可用性中断
- 自动断电控制
- 低功耗：
  - 在 1.2V、快速模式和 8.2kHz 均衡率的条件下，电流为 32.24 $\mu\text{A}$
  - 在 1.8V、快速模式和 8.2kHz 均衡率的条件下，电流为 39.31 $\mu\text{A}$
  - 在 2.7V、快速模式和 8.2kHz 均衡率的条件下，电流为 53.32 $\mu\text{A}$
- 增强型 ESD 保护：
  - $\pm 25\text{kV}$  气隙放电
  - $\pm 15\text{kV}$  接触放电
  - 5mm x 4.4mm 16 引脚 TSSOP 封装

NOTE: 美国专利号 6246394; 其他专利正在申请中。

## 2 应用

- 车用信息娱乐显示屏
- 汽车导航系统
- 工业用户界面
- 多屏触摸控制系统

## 3 说明

TSC2007-Q1 器件是一款超低功耗触摸屏控制器，旨在与功耗敏感型汽车触摸显示屏结合使用。它具有完整的超低功耗 12 位模数转换 (A-D) 电阻式触摸屏转换器，包括驱动器和用于测量触摸压力的控制逻辑。

除了这些标准特性外，TSC2007-Q1 还提供触摸屏测量预处理能力以减少总线负载，从而减少主处理器资源的消耗，而将这些资源分配给更关键的功能。

在所有三种定义的模式（标准、快速和高速）下，TSC2007-Q1 均支持 I<sup>2</sup>C 串行总线和数据传输协议。它提供 8 位或 12 位的可编程分辨率，以适应不同的屏幕尺寸和性能需求。

TSC2007-Q1 采用 16 引脚 TSSOP 封装。TSC2007-Q1 的额定工业温度范围为  $-40^{\circ}\text{C}$  至  $85^{\circ}\text{C}$ 。

### 器件信息(1)

器件型号	封装	封装尺寸 (标称值)
TSC2007-Q1	TSSOP (16)	5.00mm x 4.40mm

(1) 如需了解所有可用封装，请参阅数据表末尾的可订购产品附录。

### 功能框图

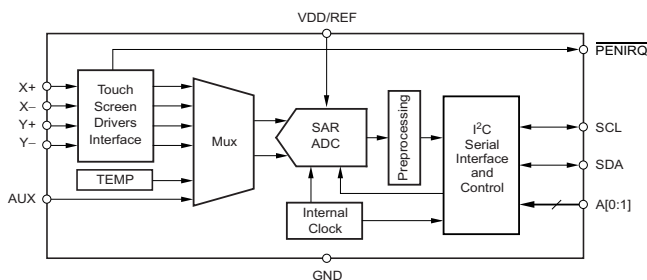

Copyright © 2016, Texas Instruments Incorporated



## 目录

1	特性 .....	1	7.2	Functional Block Diagram .....	12
2	应用 .....	1	7.3	Feature Description .....	12
3	说明 .....	1	7.4	Device Functional Modes .....	19
4	修订历史 .....	2	7.5	Programming .....	19
5	<b>Pin Configuration and Functions</b> .....	3	<b>8</b>	<b>Application and Implementation</b> .....	29
6	<b>Specifications</b> .....	4	8.1	Application Information .....	29
6.1	Absolute Maximum Ratings .....	4	8.2	Typical Application .....	29
6.2	ESD Ratings .....	4	<b>9</b>	<b>Power Supply Recommendations</b> .....	33
6.3	Recommended Operating Conditions .....	4	<b>10</b>	<b>Layout</b> .....	33
6.4	Thermal Information .....	4	10.1	Layout Guidelines .....	33
6.5	Electrical Characteristics .....	5	10.2	Layout Example .....	34
6.6	Timing Requirements: Standard Mode (SCL = 100 kHz) .....	6	<b>11</b>	<b>器件和文档支持</b> .....	35
6.7	Timing Requirements: Fast Mode (SCL = 400 kHz) ..	7	11.1	器件支持 .....	35
6.8	Timing Requirements: High-Speed Mode (SCL = 1.7 MHz) .....	7	11.2	文档支持 .....	35
6.9	Timing Requirements: High-Speed Mode (SCL = 3.4 MHz) .....	8	11.3	接收文档更新通知 .....	35
6.10	Typical Characteristics .....	9	11.4	社区资源 .....	35
<b>7</b>	<b>Detailed Description</b> .....	12	11.5	商标 .....	35
7.1	Overview .....	12	11.6	静电放电警告 .....	35
			11.7	Glossary .....	35
			<b>12</b>	<b>机械、封装和可订购信息</b> .....	35

## 4 修订历史

注：之前版本的页码可能与当前版本有所不同。

Changes from Original (September 2011) to Revision A	Page
• 已添加 器件信息表、规格部分、ESD 额定值表、建议运行条件表、详细 说明部分、应用和实施部分、电源建议部 分、布局指南部分、布局示例部分、器件和文档支持部分以及机械、封装和可订购信息部分 .....	1
• 已删除 订购信息表；请参阅数据表末尾的“封装选项附录” .....	1
• 已更改 更改了 ESD 额定值信息并将 AEC-Q100 汽车项目符号添加到特性将“汽车信息娱乐显示屏”和“汽车导航系统” 项目符号 .....	1
• 已添加 添加到应用 .....	1
• 已删除 将“数字缓冲 $\overline{\text{PENIRQ}}$ ”项目符号从特性中删除 .....	1
• 已删除 将“可编程的片上 $\overline{\text{PENIRQ}}$ 上拉电阻”项目符号从特性中删除 .....	1
• 已删除 从绝对最大额定值中删除了引线温度参数 .....	1
• 将电源电压参数从电气特性表移到了建议运行条件表 .....	1
• Added IEC discharge information .....	4
• Added <i>Thermal Information</i> table .....	4
• Changed $R_{\theta\text{JA}}$ values for PW (TSSOP) From: 86 To: 101.7 .....	4
• Changed $t_{\text{OF}}$ to $t_{\text{F}}$ in Timing Requirements tables .....	6
• Changed text in Reference mode to clarify singled-ended operation .....	15
• Changed <b>Figure 24</b> caption text from $\overline{\text{PINTDAV}}$ to $\overline{\text{PENIRQ}}$ .....	18
• Added subsections to <i>Throughput Rate and I2C Bus Traffic</i> section to clarify 8-bit and 12-bit operation .....	26

## 5 Pin Configuration and Functions

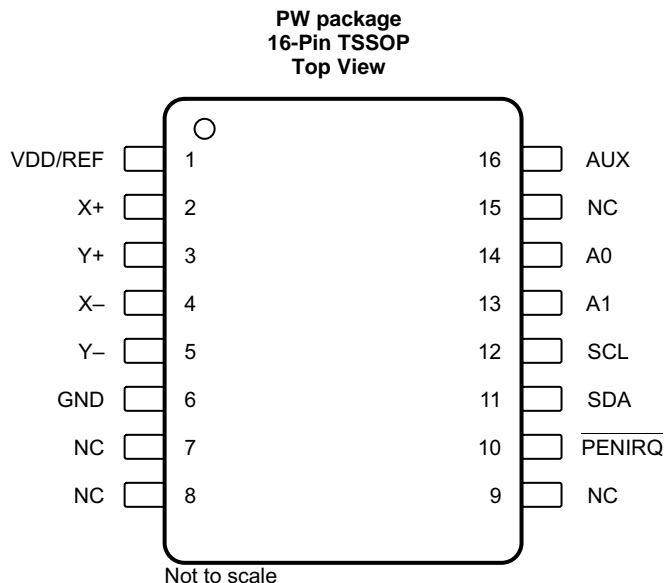

### Pin Functions

PIN		I/O	A/D	DESCRIPTION
NAME	NO.			
A0	14	Input	Digital	Address input bit 0
A1	13	Input	Digital	Address input bit 1
AUX	16	Input	Analog	Auxiliary channel input
GND	6	—	—	Ground
NC	7, 8, 9, 15	—	—	No connection
$\overline{\text{PENIRQ}}$	10	Output	Digital	Data available interrupt output. A delayed (process delay) pen touch detect. Pin polarity with active low.
SCL	12	Input and Output	Digital	Serial clock. This pin is normally an input, but acts as an output when the device stretches the clock to delay a bus transfer.
SDA	11	Input and Output	Digital	Serial data I/O
VDD/REF	1	Input	—	Supply voltage and external reference input
X+	2	Input	Analog	X+ channel input
X-	4	Input	Analog	X- channel input
Y+	3	Input	Analog	Y+ channel input
Y-	5	Input	Analog	Y- channel input

## 6 Specifications

### 6.1 Absolute Maximum Ratings

Over operating free-air temperature range (unless otherwise noted).<sup>(1)</sup>

		MIN	MAX	UNIT
Analog input voltage	X+, Y+, AUX to GND	-0.4	V <sub>DD</sub> + 0.1	V
	X-, Y- to GND	-0.4	V <sub>DD</sub> + 0.1	
Voltage	VDD/REF pin to GND	-0.3	5	V
Digital input voltage to GND		-0.3	V <sub>DD</sub> + 0.3	V
Digital output voltage to GND		-0.3	V <sub>DD</sub> + 0.3	V
Power dissipation		$(T_{J(MAX)} - T_A) / R_{\theta JA}$		
Operating free-air temperature, T <sub>A</sub>		-40	85	°C
Junction temperature, T <sub>J</sub>			150	°C
Storage temperature, T <sub>stg</sub>		-65	150	°C

- (1) Stresses beyond those listed under *Absolute Maximum Ratings* may cause permanent damage to the device. These are stress ratings only, which do not imply functional operation of the device at these or any other conditions beyond those indicated under *Recommended Operating Conditions*. Exposure to absolute-maximum-rated conditions for extended periods may affect device reliability.

### 6.2 ESD Ratings

		VALUE	UNIT
V <sub>(ESD)</sub> Electrostatic discharge	Human-body model (HBM), per AEC Q100-002 <sup>(1)</sup>	±8000	V
	Charged-device model (CDM), per AEC Q100-011	±1000	
	IEC 61000-4-2 contact discharge <sup>(2)</sup>	Pins 2, 3, 4, and 5 ±15000	
	IEC 61000-4-2 air-gap discharge <sup>(2)</sup>	Pins 2, 3, 4, and 5 ±25000	

- (1) AEC Q100-002 indicates that HBM stressing shall be in accordance with the ANSI/ESDA/JEDEC JS-001 specification.  
 (2) Test method based on IEC standard 61000-4-2. Contact Texas Instruments for test details.

### 6.3 Recommended Operating Conditions

over operating free-air temperature range (unless otherwise noted)

		MIN	MAX	UNIT	
V <sub>DD</sub>	Power-supply voltage	VDD	1.2	3.6	V

### 6.4 Thermal Information

THERMAL METRIC <sup>(1)</sup>		TSC2007-Q1	UNIT
		PW (TSSOP)	
		16 PINS	
R <sub>θJA</sub>	Junction-to-ambient thermal resistance	101.7	°C/W
R <sub>θJC(top)</sub>	Junction-to-case (top) thermal resistance	35.2	°C/W
R <sub>θJB</sub>	Junction-to-board thermal resistance	47.7	°C/W
ψ <sub>JT</sub>	Junction-to-top characterization parameter	2.4	°C/W
ψ <sub>JB</sub>	Junction-to-board characterization parameter	47	°C/W

- (1) For more information about traditional and new thermal metrics, see the [Semiconductor and IC Package Thermal Metrics](#) application report.

## 6.5 Electrical Characteristics

 $T_A = -40^{\circ}\text{C}$  to  $85^{\circ}\text{C}$ ,  $V_{DD} = 1.2\text{ V}$  to  $3.6\text{ V}$  (unless otherwise noted).

PARAMETER		TEST CONDITIONS	MIN	TYP	MAX	UNIT
<b>AUXILIARY ANALOG INPUT</b>						
Input voltage range			0		$V_{DD}$	V
Input capacitance				12		pF
Input leakage current			-1		1	$\mu\text{A}$
<b>A-D CONVERTER</b>						
Resolution		Programmable: 8 bits or 12 bits			12	Bits
No missing codes		12-bit resolution	11			Bits
Integral linearity				$\pm 1.5$		LSB <sup>(1)</sup>
Offset error		$V_{DD} = 1.8\text{ V}$		-1.2		LSB
		$V_{DD} = 3\text{ V}$		-3.1		LSB
Gain error		$V_{DD} = 1.8\text{ V}$		0.7		LSB
		$V_{DD} = 3\text{ V}$		0.1		LSB
<b>TOUCH SENSORS</b>						
$\overline{\text{PENIRQ}}$ pullup resistor, $R_{\text{IRQ}}$		$T_A = 25^{\circ}\text{C}$ , $V_{DD} = 1.8\text{ V}$ , command 1011 set 0000		51		k $\Omega$
		$T_A = 25^{\circ}\text{C}$ , $V_{DD} = 1.8\text{ V}$ , command 1011 set 0001		90		k $\Omega$
Switch ON-resistance		Y+, X+		6		$\Omega$
		Y-, X-		5		$\Omega$
Switch drivers drive current <sup>(2)(3)</sup>		100-ms duration			50	mA
<b>INTERNAL TEMPERATURE SENSOR</b>						
Temperature range			-40		85	$^{\circ}\text{C}$
Resolution		Differential method <sup>(4)</sup>	$V_{DD} = 3\text{ V}$	1.94		$^{\circ}\text{C}/\text{LSB}$
			$V_{DD} = 1.6\text{ V}$	1.04		$^{\circ}\text{C}/\text{LSB}$
		TEMP1 <sup>(5)</sup>	$V_{DD} = 3\text{ V}$	0.35		$^{\circ}\text{C}/\text{LSB}$
			$V_{DD} = 1.6\text{ V}$	0.19		$^{\circ}\text{C}/\text{LSB}$
Accuracy		Differential method <sup>(4)</sup>	$V_{DD} = 3\text{ V}$	$\pm 2$		$^{\circ}\text{C}/\text{LSB}$
			$V_{DD} = 1.6\text{ V}$	$\pm 2$		$^{\circ}\text{C}/\text{LSB}$
		TEMP1 <sup>(5)</sup>	$V_{DD} = 3\text{ V}$	$\pm 3$		$^{\circ}\text{C}/\text{LSB}$
			$V_{DD} = 1.6\text{ V}$	$\pm 3$		$^{\circ}\text{C}/\text{LSB}$
<b>INTERNAL OSCILLATOR</b>						
Internal clock frequency, $f_{\text{CLK}}$		8-Bit	$V_{DD} = 1.2\text{ V}$	3.19		MHz
			$V_{DD} = 1.8\text{ V}$	3.66		MHz
			$V_{DD} = 2.7\text{ V}$	3.78		MHz
			$V_{DD} = 3.6\text{ V}$	3.82		MHz
		12-Bit	$V_{DD} = 1.2\text{ V}$	1.6		MHz
			$V_{DD} = 1.8\text{ V}$	1.83		MHz
			$V_{DD} = 2.7\text{ V}$	1.88		MHz
			$V_{DD} = 3.6\text{ V}$	1.91		MHz
Frequency drift		$V_{DD} = 1.6\text{ V}$		0.0056		$\%/^{\circ}\text{C}$
		$V_{DD} = 3\text{ V}$		0.012		$\%/^{\circ}\text{C}$

(1) LSB means Least Significant Bit. With  $V_{DD}/\text{REF}$  pin = 1.6 V, one LSB is 391  $\mu\text{V}$ .

(2) Not production tested. Specified by design.

(3) Exceeding 50-mA source current may result in device degradation.

(4) Difference between TEMP1 and TEMP2 measurement; no calibration necessary.

(5) Temperature drift is  $-2.1\text{ mV}/^{\circ}\text{C}$ .

**Electrical Characteristics (continued)**
 $T_A = -40^{\circ}\text{C}$  to  $85^{\circ}\text{C}$ ,  $V_{DD} = 1.2\text{ V}$  to  $3.6\text{ V}$  (unless otherwise noted).

PARAMETER		TEST CONDITIONS	MIN	TYP	MAX	UNIT
<b>DIGITAL INPUT AND OUTPUT</b>						
Logic family			CMOS			
Logic level	$V_{IH}$	$1.2\text{ V} \leq V_{DD} < 1.6\text{ V}$	$0.7 \times V_{DD}$	$V_{DD} + 0.3$		V
		$1.6\text{ V} \leq V_{DD} \leq 3.6\text{ V}$	$0.7 \times V_{DD}$	$V_{DD} + 0.3$		V
	$V_{IL}$	$1.2\text{ V} \leq V_{DD} < 1.6\text{ V}$	-0.3	$0.2 \times V_{DD}$		V
		$1.6\text{ V} \leq V_{DD} \leq 3.6\text{ V}$	-0.3	$0.3 \times V_{DD}$		V
	$I_{IL}$	SCL and SDA pins	-1		1	$\mu\text{A}$
	$C_{IN}^{(2)}$	SCL and SDA pins			10	pF
	$V_{OH}$	$I_{OH} = 2\text{ TTL loads}$	$V_{DD} - 0.2$		$V_{DD}$	V
	$V_{OL}$	$I_{OL} = 2\text{ TTL loads}$	0		0.2	V
$I_{LEAK}$	Floating output	-1		1	$\mu\text{A}$	
$C_{OUT}^{(2)}$	Floating output			10	pF	
Data format			Straight binary			
<b>POWER-SUPPLY REQUIREMENTS</b>						
Quiescent supply current ( $V_{DD}$ with sensor off)	12-bit Fast mode (clock = 400 kHz) PD[1:0] = 0,0	$V_{DD} = 1.2\text{ V}$ , 32.56k eq rate		128	190	$\mu\text{A}$
		$V_{DD} = 1.2\text{ V}$ , 8.2k eq rate		32.24		$\mu\text{A}$
		$V_{DD} = 1.8\text{ V}$ , 34.42k eq rate		165	240	$\mu\text{A}$
		$V_{DD} = 1.8\text{ V}$ , 8.2k eq rate		39.31		$\mu\text{A}$
		$V_{DD} = 2.7\text{ V}$ , 34.79k eq rate		226.2	335	$\mu\text{A}$
		$V_{DD} = 2.7\text{ V}$ , 8.2k eq rate		53.32		$\mu\text{A}$
Power down supply current	Not addressed, SCL = SDA = 1		0	0.8	$\mu\text{A}$	
<b>POWER-ON AND OFF SLOPE REQUIREMENTS<sup>(2)</sup></b>						
$V_{DD}$ off ramp	$T_A = -40^{\circ}\text{C}$ to $85^{\circ}\text{C}$		2			kV/s
$V_{DD}$ off time	$T_A = -40^{\circ}\text{C}$ to $85^{\circ}\text{C}$ , $V_{DD} = 0\text{ V}$		1.2			s
	$T_A = -20^{\circ}\text{C}$ to $85^{\circ}\text{C}$ , $V_{DD} = 0\text{ V}$		0.3			s
$V_{DD}$ on ramp	$T_A = -40^{\circ}\text{C}$ to $85^{\circ}\text{C}$		12			kV/s

**6.6 Timing Requirements: Standard Mode (SCL = 100 kHz)**
 $T_A = -40^{\circ}\text{C}$  to  $85^{\circ}\text{C}$ ,  $V_{DD} = 1.6\text{ V}$  (unless otherwise noted).

		MIN	NOM	MAX	UNIT
$f_{SCL}$	SCL clock frequency	0		100	kHz
$t_{BUF}$	Bus free time between a STOP and START condition	4.7			$\mu\text{s}$
$t_{HD, STA}$	Hold time (repeated) START condition	4			$\mu\text{s}$
$t_{LOW}$	Low period of SCL clock	4.7			$\mu\text{s}$
$t_{HIGH}$	High period of the SCL clock	4			$\mu\text{s}$
$t_{SU, STA}$	Setup time for a repeated START condition	4.7			$\mu\text{s}$
$t_{HD, DAT}$	Data hold time	0		3.45	$\mu\text{s}$
$t_{SU, DAT}$	Data setup time	250			ns
$t_R$	Rise time for both SDA and SCL signals (receiving)		$C_b = \text{total bus capacitance}$	1000	ns
$t_F$	Fall time for both SDA and SCL signals	Receiving	$C_b = \text{total bus capacitance}$	300	ns
		Transmitting	$C_b = \text{total bus capacitance}$	250	ns
$t_{SU, STO}$	Setup time for STOP condition	4			$\mu\text{s}$
$C_b$	Capacitive load for each bus line		$C_b = \text{total capacitance of one bus line in pF}$	400	pF
Cycle time	8 bits		40 SCL + 127 CCLK, $V_{DD} = 1.8\text{ V}$	434.7	$\mu\text{s}$
	12 bits		49 SCL + 148 CCLK, $V_{DD} = 1.8\text{ V}$	570.9	$\mu\text{s}$
Effective throughput	8 bits		$V_{DD} = 1.8\text{ V}$	2.3	kSPS
	12 bits		$V_{DD} = 1.8\text{ V}$	1.75	kSPS
Equivalent rate = effective throughput $\times 7$	8 bits		$V_{DD} = 1.8\text{ V}$	16.1	kHz
	12 bits		$V_{DD} = 1.8\text{ V}$	12.26	kHz

## 6.7 Timing Requirements: Fast Mode (SCL = 400 kHz)

All specifications typical at  $-40^{\circ}\text{C}$  to  $85^{\circ}\text{C}$ ,  $V_{\text{DD}} = 1.6\text{ V}$  (unless otherwise noted).

			MIN	NOM	MAX	UNIT
$f_{\text{SCL}}$	SCL clock frequency		0		400	kHz
$t_{\text{BUF}}$	Bus free time between a STOP and START condition		1.3			$\mu\text{s}$
$t_{\text{HD, STA}}$	Hold time (repeated) START condition		0.6			$\mu\text{s}$
$t_{\text{LOW}}$	Low period of SCL clock		1.3			$\mu\text{s}$
$t_{\text{HIGH}}$	High period of the SCL clock		0.6			$\mu\text{s}$
$t_{\text{SU, STA}}$	Setup time for a repeated START condition		0.6			$\mu\text{s}$
$t_{\text{HD, DAT}}$	Data hold time		0		0.9	$\mu\text{s}$
$t_{\text{SU, DAT}}$	Data setup time		100			ns
$t_{\text{R}}$	Rise time for both SDA and SCL signals (receiving)	$C_b = \text{total bus capacitance}$	$20 + 0.1 \times C_b$		300	ns
$t_{\text{F}}$	Fall time for both SDA and SCL signals	Receiving	$C_b = \text{total bus capacitance}$		300	ns
		Transmitting	$C_b = \text{total bus capacitance}$		250	ns
$t_{\text{SU, STO}}$	Setup time for STOP condition		0.6			$\mu\text{s}$
$C_b$	Capacitive load for each bus line		$C_b = \text{total capacitance of one bus line in pF}$		400	pF
Cycle time	8 bits	40 SCL + 127 CCLK, $V_{\text{DD}} = 1.8\text{ V}$		134.7		$\mu\text{s}$
	12 bits	49 SCL + 148 CCLK, $V_{\text{DD}} = 1.8\text{ V}$		203.4		$\mu\text{s}$
Effective throughput	8 bits	$V_{\text{DD}} = 1.8\text{ V}$		7.42		kSPS
	12 bits	$V_{\text{DD}} = 1.8\text{ V}$		4.92		kSPS
Equivalent rate = effective throughput $\times 7$	8 bits	$V_{\text{DD}} = 1.8\text{ V}$		51.97		kHz
	12 bits	$V_{\text{DD}} = 1.8\text{ V}$		34.42		kHz

## 6.8 Timing Requirements: High-Speed Mode (SCL = 1.7 MHz)

All specifications typical at  $-40^{\circ}\text{C}$  to  $85^{\circ}\text{C}$ ,  $V_{\text{DD}} = 1.6\text{ V}$  (unless otherwise noted).

			MIN	NOM	MAX	UNIT
$f_{\text{SCL}}$	SCL clock frequency		0		1.7	MHz
$t_{\text{HD, STA}}$	Hold time (repeated) START condition		160			ns
$t_{\text{LOW}}$	Low period of SCL clock		320			ns
$t_{\text{HIGH}}$	High period of the SCL clock		120			ns
$t_{\text{SU, STA}}$	Setup time for a repeated START condition		160			ns
$t_{\text{HD, DAT}}$	Data hold time		0		150	ns
$t_{\text{SU, DAT}}$	Data setup time		10			ns
$t_{\text{R}}$	Rise time for a signal (receiving)	SCL	$C_b = \text{total bus capacitance}$	20	80	ns
		SDA	$C_b = \text{total bus capacitance}$	20	160	ns
$t_{\text{F}}$	Fall time for a signal (receiving)	SCL	$C_b = \text{total bus capacitance}$	20	80	ns
		SDA	$C_b = \text{total bus capacitance}$	20	160	ns
$t_{\text{F}}$	Fall time for both SDA and SCL signals (transmitting)		$C_b = \text{total bus capacitance}$	20	160	ns
$t_{\text{SU, STO}}$	Setup time for STOP condition		160			ns
$C_b$	Capacitive load for each bus line		$C_b = \text{total capacitance of one bus line in pF}$		400	pF
Cycle time	8 bits	40 SCL + 127 CCLK, $V_{\text{DD}} = 1.8\text{ V}$		58.2		$\mu\text{s}$
	12 bits	49 SCL + 148 CCLK, $V_{\text{DD}} = 1.8\text{ V}$		109.7		$\mu\text{s}$
Effective throughput	8 bits	$V_{\text{DD}} = 1.8\text{ V}$		17.17		kSPS
	12 bits	$V_{\text{DD}} = 1.8\text{ V}$		9.12		kSPS
Equivalent rate = effective throughput $\times 7$	8 bits	$V_{\text{DD}} = 1.8\text{ V}$		120.22		kHz
	12 bits	$V_{\text{DD}} = 1.8\text{ V}$		63.81		kHz

## 6.9 Timing Requirements: High-Speed Mode (SCL = 3.4 MHz)

All specifications typical at  $-40^{\circ}\text{C}$  to  $85^{\circ}\text{C}$ ,  $V_{\text{DD}} = 1.6\text{ V}$  (unless otherwise noted).

		MIN	NOM	MAX	UNIT	
$f_{\text{SCL}}$	SCL clock frequency	0		3.4	MHz	
$t_{\text{HD, STA}}$	Hold time (repeated) START condition	160			ns	
$t_{\text{LOW}}$	Low period of SCL clock	160			ns	
$t_{\text{HIGH}}$	High period of the SCL clock	60			ns	
$t_{\text{SU, STA}}$	Setup time for a repeated START condition	160			ns	
$t_{\text{HD, DAT}}$	Data hold time	0		70	ns	
$t_{\text{SU, DAT}}$	Data setup time	10			ns	
$t_{\text{R}}$	Rise time for a signal (receiving)	SCL	$C_b = \text{total bus capacitance}$	10	40	ns
		SDA	$C_b = \text{total bus capacitance}$	10	80	ns
$t_{\text{F}}$	Fall time for a signal (receiving)	SCL	$C_b = \text{total bus capacitance}$	10	40	ns
		SDA	$C_b = \text{total bus capacitance}$	10	80	ns
$t_{\text{F}}$	Fall time for both SDA and SCL signals (transmitting)		$C_b = \text{total bus capacitance}$	10	80	ns
$t_{\text{SU, STO}}$	Setup time for STOP condition	160			ns	
$C_b$	Capacitive load for each bus line		$C_b = \text{total capacitance of one bus line in pF}$	100	pF	
Cycle time	8 bits		40 SCL + 127 CCLK, $V_{\text{DD}} = 1.8\text{ V}$	46.5	$\mu\text{s}$	
	12 bits		49 SCL + 148 CCLK, $V_{\text{DD}} = 1.8\text{ V}$	95.3	$\mu\text{s}$	
Effective throughput	8 bits		$V_{\text{DD}} = 1.8\text{ V}$	21.52	kSPS	
	12 bits		$V_{\text{DD}} = 1.8\text{ V}$	10.49	kSPS	
Equivalent rate = effective throughput $\times 7$	8 bits		$V_{\text{DD}} = 1.8\text{ V}$	150.65	kHz	
	12 bits		$V_{\text{DD}} = 1.8\text{ V}$	73.46	kHz	

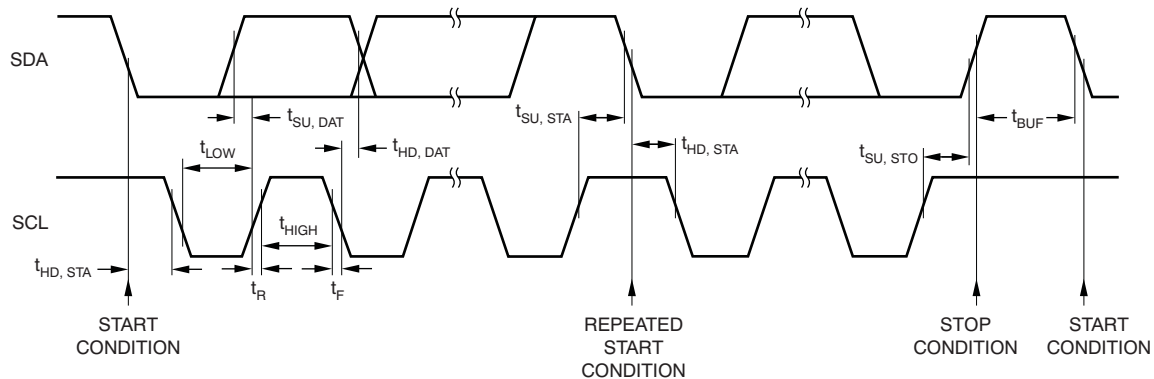

**Figure 1. Detailed I/O Timing**

### 6.10 Typical Characteristics

At  $T_A = -40^\circ\text{C}$  to  $85^\circ\text{C}$ ,  $V_{DD} = 1.2\text{ V}$  to  $3.6\text{ V}$ ,  $\text{PD1} = \text{PD0} = 0$ , Fast mode, 12-bit mode, non-continuous AUX measurement, and MAV filter enabled (see [MAV Filter](#) section), unless otherwise noted.

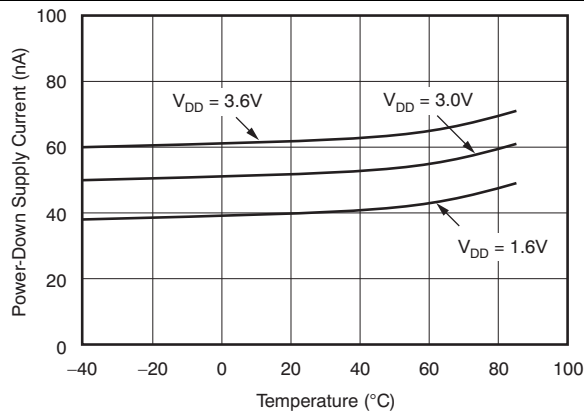

Figure 2. Power-Down Supply Current vs Temperature

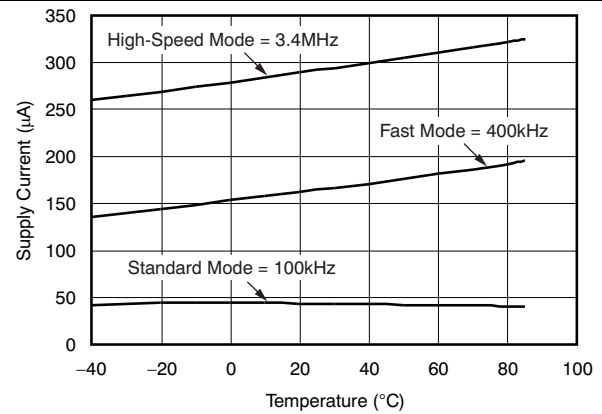

Figure 3. Supply Current vs Temperature

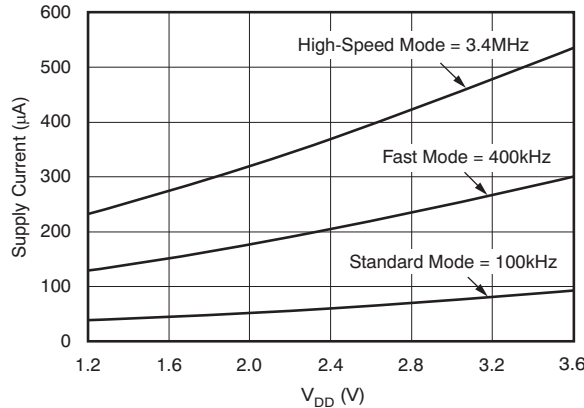

Figure 4. Supply Current vs Supply Voltage (AUX Conversion)

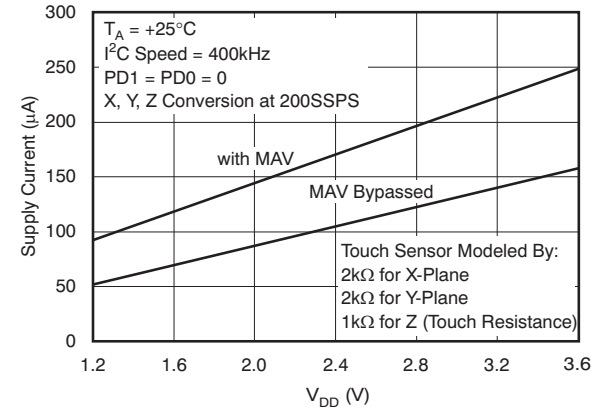

Figure 5. Supply Current vs Supply Voltage

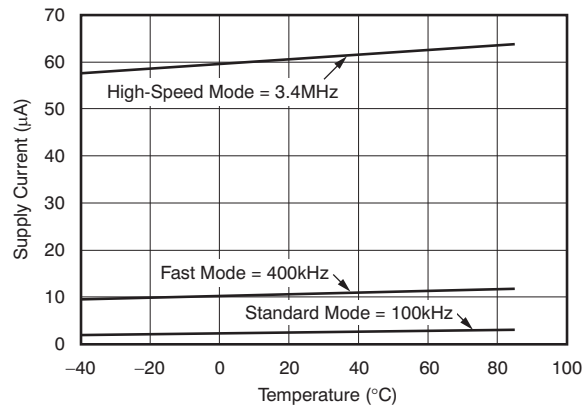

Figure 6. Supply Current (Part Not Addressed) vs Temperature

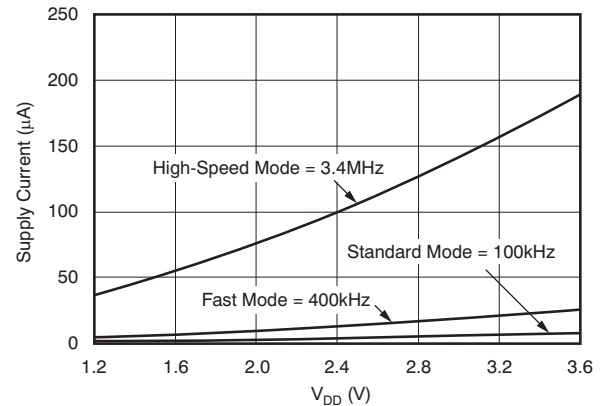

Figure 7. Supply Current (Part Not Addressed) vs Supply Voltage

### Typical Characteristics (continued)

At  $T_A = -40^\circ\text{C}$  to  $85^\circ\text{C}$ ,  $V_{DD} = 1.2\text{ V}$  to  $3.6\text{ V}$ ,  $PD1 = PD0 = 0$ , Fast mode, 12-bit mode, non-continuous AUX measurement, and MAV filter enabled (see [MAV Filter](#) section), unless otherwise noted.

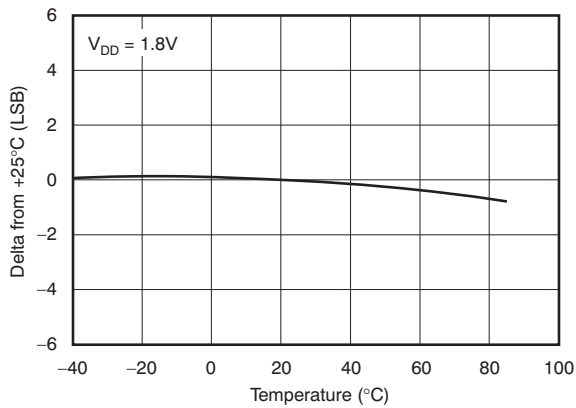

Figure 8. Change in Gain vs Temperature

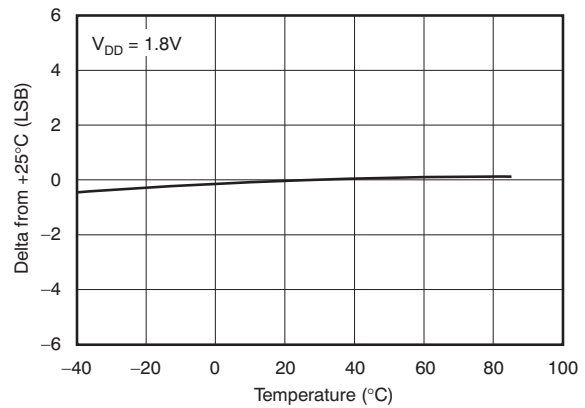

Figure 9. Change in Gain vs Temperature

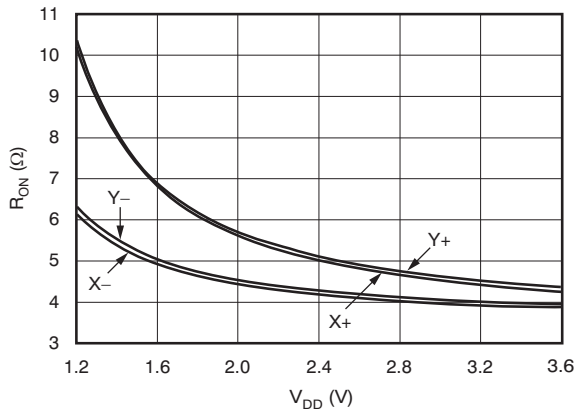

Figure 10. Switch ON-Resistance vs Supply Voltage

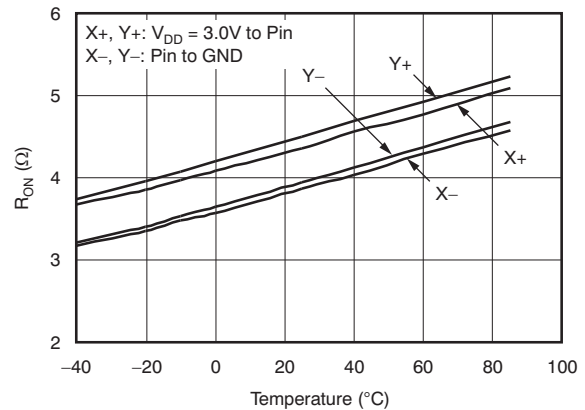

Figure 11. Switch ON-Resistance vs Temperature

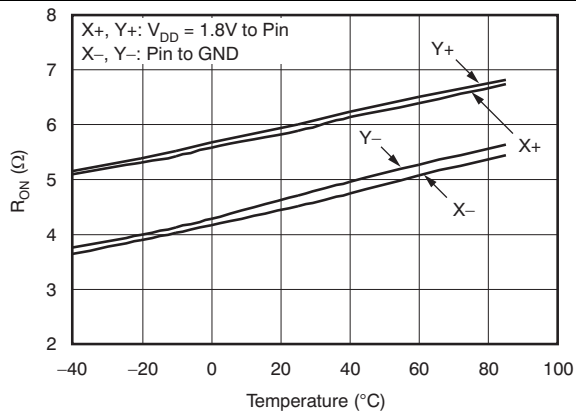

Figure 12. Switch ON-Resistance vs Temperature

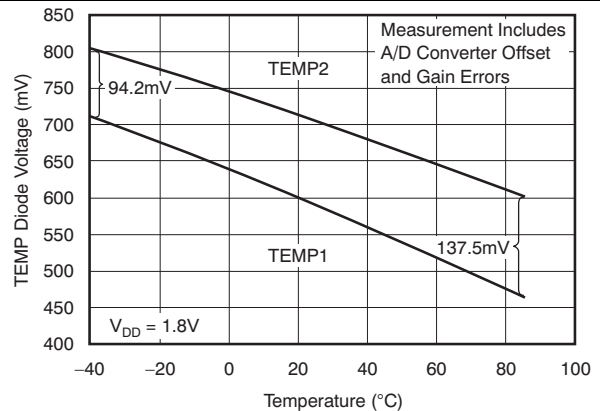

Figure 13. TEMP Diode Voltage vs Temperature

Typical Characteristics (continued)

At  $T_A = -40^{\circ}\text{C}$  to  $85^{\circ}\text{C}$ ,  $V_{DD} = 1.2\text{ V}$  to  $3.6\text{ V}$ ,  $\text{PD1} = \text{PD0} = 0$ , Fast mode, 12-bit mode, non-continuous AUX measurement, and MAV filter enabled (see [MAV Filter](#) section), unless otherwise noted.

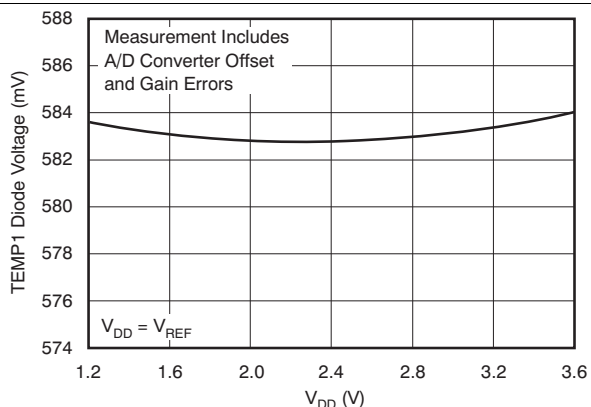

Figure 14. TEMP1 Diode Voltage vs Supply Voltage

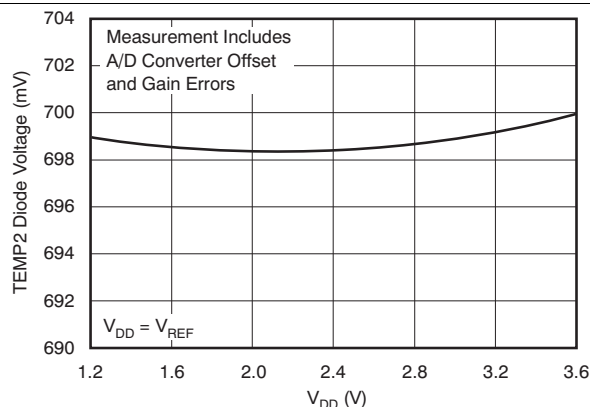

Figure 15. TEMP2 Diode Voltage vs Supply Voltage

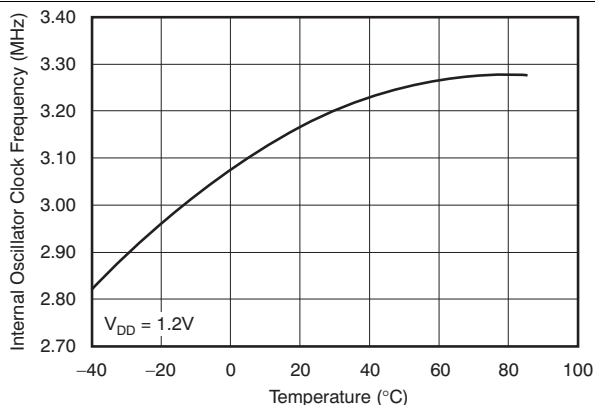

Figure 16. Internal Oscillator Clock Frequency vs Temperature

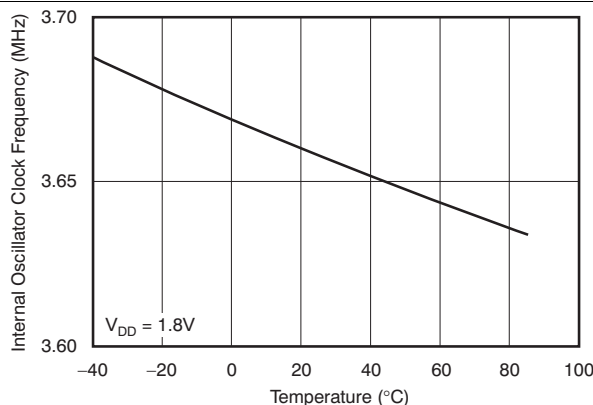

Figure 17. Internal Oscillator Clock Frequency vs Temperature

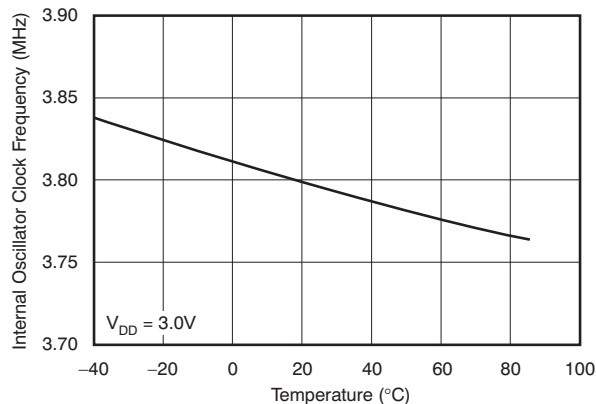

Figure 18. Internal Oscillator Clock Frequency vs Temperature

## 7 Detailed Description

### 7.1 Overview

The TSC2007-Q1 is an analog interface circuit for a human interface touch screen devices. All peripheral functions are controlled through the command byte and onboard state machines. The TSC2007-Q1 features include:

- Very low-power touch screen controller
- Very small onboard footprint
- Relieves host from tedious routine tasks by preprocessing, thus saving resources for more critical tasks
- Ability to work on very low supply voltage
- Minimal connection interface allows easy isolation and reduces the number of dedicated I/O pins required
- Miniature, yet complete; requires no external supporting components
- Enhanced electrostatic discharge (ESD) protection

The TSC2007-Q1 consists of the following blocks (see [Functional Block Diagram](#)):

- Touch Screen Sensor Interface
- Auxiliary Input (AUX)
- Temperature Sensor
- Acquisition Activity Preprocessing
- Internal Conversion Clock
- I<sup>2</sup>C Interface

Communication with the TSC2007-Q1 is done through an I<sup>2</sup>C serial interface. The TSC2007-Q1 is an I<sup>2</sup>C slave device; therefore, data are shifted into or out of the TSC2007-Q1 under control of the host microprocessor, which also provides the serial data clock.

Control of the TSC2007-Q1 and its functions is accomplished by writing to the command register of an internal state machine. A simple command protocol compatible with I<sup>2</sup>C is used to address this register.

### 7.2 Functional Block Diagram

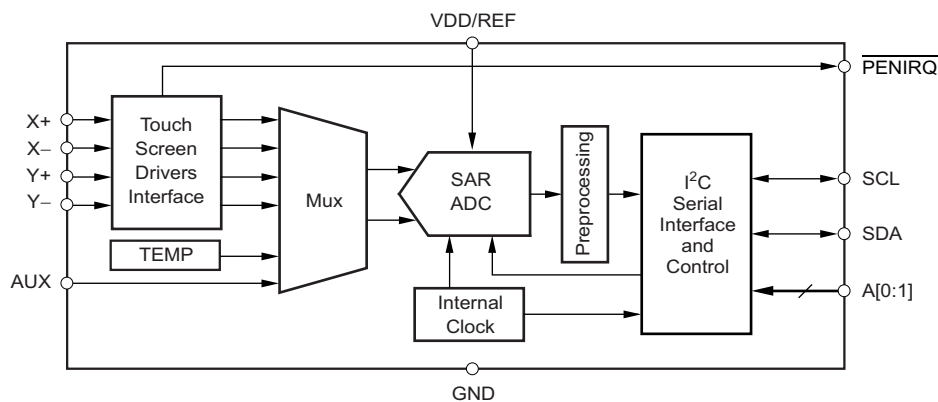

Copyright © 2016, Texas Instruments Incorporated

### 7.3 Feature Description

#### 7.3.1 Touch Screen Operation

A resistive touch screen operates by applying a voltage across a resistor network and measuring the change in resistance at a given point on the matrix where the screen is touched by an input (stylus, pen, or finger). The change in the resistance ratio marks the location on the touch screen.

The TSC2007-Q1 supports resistive 4-wire configurations, as shown in [Figure 35](#). The circuit determines location in two coordinate pair dimensions, although a third dimension can be added for measuring pressure.

## Feature Description (continued)

### 7.3.2 Internal Temperature Sensor

In some applications, such as battery recharging, an ambient temperature measurement is required. The temperature measurement technique used in the TSC2007-Q1 relies on the characteristics of a semiconductor junction operating at a fixed current level. The forward diode voltage ( $V_{BE}$ ) has a well-defined characteristic versus temperature. The ambient temperature can be predicted in applications by knowing the 25°C value of the  $V_{BE}$  voltage and then monitoring the delta of that voltage as the temperature changes.

The TSC2007-Q1 offers two modes of temperature measurement. The first mode requires calibration at a known temperature, but only requires a single reading to predict the ambient temperature. The TEMP1 diode, shown in Figure 19, is used during this measurement cycle. This voltage is typically 580 mV at 25°C with a 10- $\mu$ A current. The absolute value of this diode voltage can vary by a few millivolts; the temperature coefficient ( $T_C$ ) of this voltage is very consistent at  $-2.1$  mV/°C. During the final test of the end product, the diode voltage would be stored at a known room temperature, in system memory, for calibration purposes by the user. The result is an equivalent temperature measurement resolution of 0.35°C/LSB (1 LSB = 732  $\mu$ V with  $V_{REF} = 3$  V).

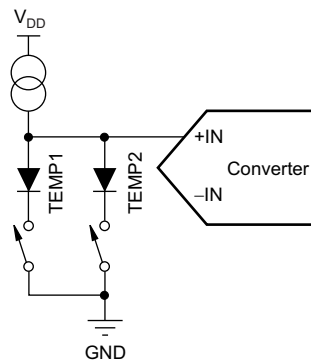

Copyright © 2016, Texas Instruments Incorporated

**Figure 19. Functional Block Diagram of Temperature Measurement Mode**

The second mode does not require a test temperature calibration, but uses a two-measurement (differential) method to eliminate the need for absolute temperature calibration and for achieving 2°C/LSB accuracy. This mode requires a second conversion of the voltage across the TEMP2 diode with a resistance 91 times larger than the TEMP1 diode. The voltage difference between the first (TEMP1) and second (TEMP2) conversion is represented by:

$$\Delta V = \frac{kT}{q} \times \ln(N)$$

where

- N = the resistance ratio = 91.
  - k = Boltzmann's constant =  $1.3807 \times 10^{-23}$  J/K (joules per kelvins).
  - q = the electron charge =  $1.6022 \times 10^{-19}$  C (coulombs).
  - T = the temperature in kelvins (K).
- (1)

This method can provide a much improved absolute temperature measurement, but a lower resolution of 1.6°C/LSB. Equation 2 solves for T:

$$T = \frac{q \times \Delta V}{k \times \ln(N)}$$

where

- $\Delta V = V_{BE}(\text{TEMP2}) - V_{BE}(\text{TEMP1})$  (in mV)
- (2)

$$\therefore T = 2.573 \times \Delta V \text{ (in K)}$$

$$\text{or } T = 2.573 \times \Delta V - 273 \text{ (in } ^\circ\text{C)}$$

## Feature Description (continued)

Temperature 1 and temperature 2 measurements have the same timing as the other data acquisition cycles shown in [Figure 32](#) and [Figure 33](#).

### 7.3.3 Analog-to-Digital Converter

[Figure 20](#) shows the analog inputs of the TSC2007-Q1. The analog inputs (X, Y, and Z touch panel coordinates, chip temperature and auxiliary inputs) are provided through a multiplexer to the Successive Approximation Register (SAR) A-D converter. The A-D architecture is based on capacitive redistribution architecture, which inherently includes a sample-and-hold function.

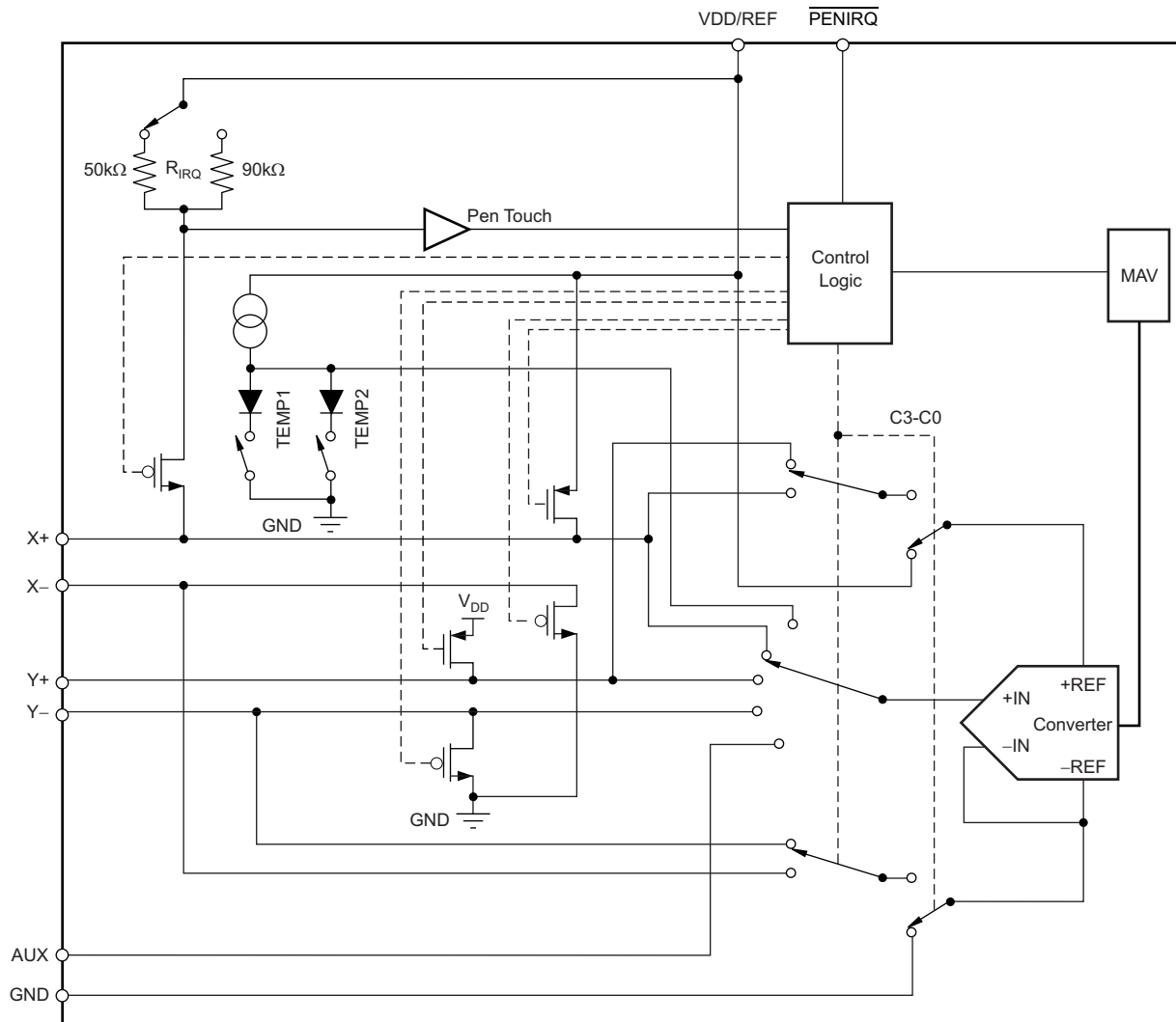

Copyright © 2016, Texas Instruments Incorporated

**Figure 20. Analog Input Section (Simplified Diagram)**

A unique configuration of low ON-resistance switches allows an unselected A-D converter input channel to provide power and an accompanying pin to provide ground for driving the touch panel. By maintaining a differential input to the converter and a differential reference input architecture, it is possible to negate errors caused by the driver switch ON-resistance.

## Feature Description (continued)

### 7.3.3.1 Reference

The TSC2007-Q1 uses an external voltage reference that is applied to the VDD/REF pin. The upper reference voltage range is the same as the supply voltage range, which allows for simple, 1.2-V to 3.6-V, single-supply operation of the chip.

### 7.3.3.2 Reference Mode

There is a critical item regarding the reference when making measurements while the switch drivers are on. For this discussion, it is useful to consider the basic operation of the TSC2007-Q1 (see [Figure 34](#)). The application used in the following example shows the device being used to digitize a resistive touch screen. If the touch screen controller uses a single-ended reference mode, as shown in [Figure 21](#), a measurement of the current Y position of the pointing device is made by connecting the X+ input to the A-D converter, turning on the Y+ and Y– drivers, and digitizing the voltage on X+. For this measurement, the resistance in the X+ lead does not affect the conversion; it does affect the settling time, but the resistance is usually small enough that this timing is not a concern. However, because the resistance between Y+ and Y– is fairly low, the ON-resistance of the Y drivers does make a small difference. Under the situation outlined so far, it would not be possible to achieve a 0-V input or a full-scale input regardless of where the pointing device is on the touch screen because some voltage is lost across the internal switches. In addition, the internal switch resistance is unlikely to track the resistance of the touch screen, providing an additional source of error. Therefore, the TSC2007-Q1 does not support single-ended reference mode.

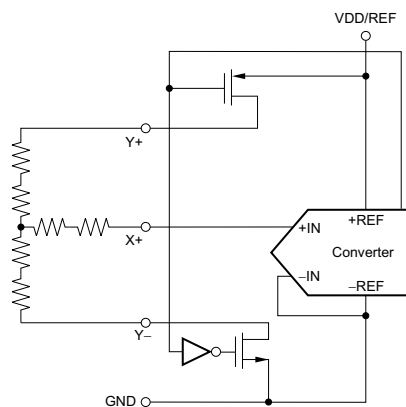

Copyright © 2016, Texas Instruments Incorporated

**Figure 21. Simplified Diagram of Single-Ended Reference**

This situation is resolved, as shown in [Figure 22](#), by using the differential mode; the +REF and –REF inputs are connected directly to Y+ and Y–, respectively. This mode makes the A-D converter ratiometric. The result of the conversion is always a percentage of the external reference, regardless of how it changes in relation to the ON-resistance of the internal switches.

## Feature Description (continued)

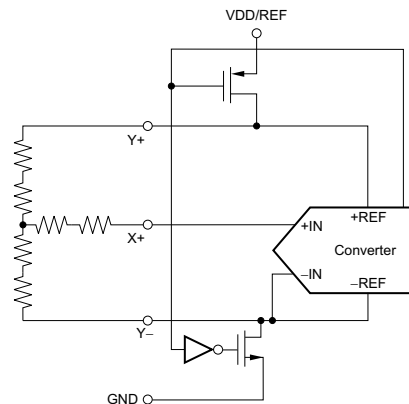

**Figure 22. Simplified Diagram of Differential Reference (Both Y Switches Enabled, X+ is Analog Input)**

### 7.3.3.3 Touch Screen Settling

In some applications, external capacitors may be required across the touch screen to filter noise picked up by the touch screen (noise generated by the LCD panel or back-light circuitry). These capacitors provide a low-pass filter to reduce the noise, but they also cause a settling time requirement when the panel is touched. The settling time typically shows up as a gain error. The problem is that the input or reference has not settled to its final steady-state value before the A-D converter samples the inputs and provides the digital output. Additionally, the reference voltage may continue to change during the measurement cycle.

To resolve these settling-time problems, the TSC2007-Q1 can be commanded to turn on the drivers only without performing a conversion (see [Table 4](#)). Time can then be allowed, before the command is issued, to perform a conversion. Generally, the time it takes to communicate the conversion command over the I<sup>2</sup>C bus is adequate for the touch screen to settle.

### 7.3.3.4 Variable Resolution

The TSC2007-Q1 provides either 8-bit or 12-bit resolution for the A-D converter. Lower resolution is often practical for measuring slow changing signals such as touch pressure. Performing the conversions at lower resolution reduces the amount of time it takes for the A-D converter to complete its conversion process, which also lowers power consumption.

### 7.3.3.5 8-Bit Conversion

The TSC2007-Q1 provides an 8-bit conversion mode ( $M = 1$ ) that can be used when faster throughput is required, and the digital result is not as critical (for example, measuring pressure). By switching to the 8-bit mode, a conversion result can be read by transferring only one data byte. The internal clock runs twice as fast at 4 MHz.

The faster clock shortens each conversion by four bits and reduces data transfer time, which results in fewer clock cycles and provides lower power consumption.

### 7.3.3.6 Conversion Clock and Conversion Time

The TSC2007-Q1 contains an internal clock, which drives the state machines inside the device that perform the many functions of the part. This clock is divided down to provide a clock that runs the A-D converter. The frequency of this clock is 4-MHz clock for 8-bit mode, and a 2-MHz clock for the 12-bit mode.

### 7.3.3.7 Data Format

The TSC2007-Q1 output data are in straight binary format as shown in [Figure 23](#). This figure shows the ideal output code for the given input voltage and does not include the effects of offset, gain, or noise.

**Feature Description (continued)**

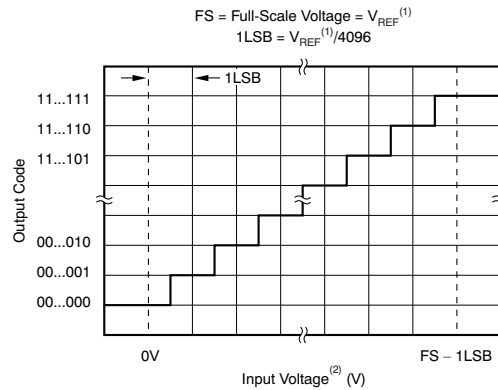

- (1) Reference voltage at converter: +REF – (–REF). See [Figure 20](#).
- (2) Input voltage at converter, after multiplexer: +IN – (–IN). See [Figure 20](#).

**Figure 23. Ideal Input Voltages and Output Codes**

**7.3.3.8 Touch Detect**

The  $\overline{PENIRQ}$  pin can be used as an interrupt to the host.  $R_{IRQ}$  is an internal pullup resistor with a programmable value of either 50 k $\Omega$  (default) or 90 k $\Omega$ . Write command 1011 (setup command) followed by data 0001 sets the pullup to 90 k $\Omega$ .

**NOTE**

The first three bits must be 0s and the select bit is the last bit. To change the pullup back to 50 k $\Omega$ , issue write command 1011 followed by data 0000.

An example for the Y-position measurement is detailed in [Figure 24](#). The  $\overline{PENIRQ}$  output is pulled high by an internal pullup. While in power-down mode with PD0 = 0, the Y– driver is on and connected to GND, and the  $\overline{PENIRQ}$  output is connected to the X+ input. When the panel is touched, the X+ input is pulled to ground through the touch screen, and the  $\overline{PENIRQ}$  output goes low because of the current path through the panel to GND, initiating an interrupt to the processor. During the measurement cycle for X, Y, and Z position, the X+ input is disconnected from the  $\overline{PENIRQ}$  pulldown transistor to eliminate any pullup resistor leakage current from flowing through the touch screen, thus causing no errors.

In addition to the measurement cycles for X, Y, and Z position, commands that activate the X-drivers, Y-drivers, and Y+ and X-drivers without performing a measurement also disconnect the X+ input from the  $\overline{PENIRQ}$  pulldown transistor, and disable the pen-interrupt output function, regardless of the value of the PD0 bit. Under these conditions, the  $\overline{PENIRQ}$  output is forced low. Furthermore, if the last command byte written to the TSC2007-Q1 contains PD0 = 1, the pen-interrupt output function is disabled and cannot detect when the panel is touched. To re-enable the pen-interrupt output function under these circumstances, a command byte must be written to the TSC2007-Q1 with PD0 = 0.

When the bus master sends the address byte with the  $\overline{R/\overline{W}}$  bit = 0, and the TSC2007-Q1 sends an acknowledge, the pen-interrupt function is disabled. If the command that follows the address byte contains PD0 = 0, then the pen-interrupt function is enabled at the end of a conversion. This action is approximately 100  $\mu$ s (12-bit mode) or 50  $\mu$ s (8-bit mode) after the TSC2007-Q1 receives a STOP or START condition, following the receipt of a command byte (see [Figure 30](#) and [Figure 29](#) for further details about when the conversion cycle begins).

In both cases previously listed, TI recommends that whenever the host writes to the TSC2007-Q1, the master processor masks the interrupt associated to  $\overline{PENIRQ}$ . This masking prevents false triggering of interrupts when the  $\overline{PENIRQ}$  line is disabled in the cases previously listed.

Feature Description (continued)

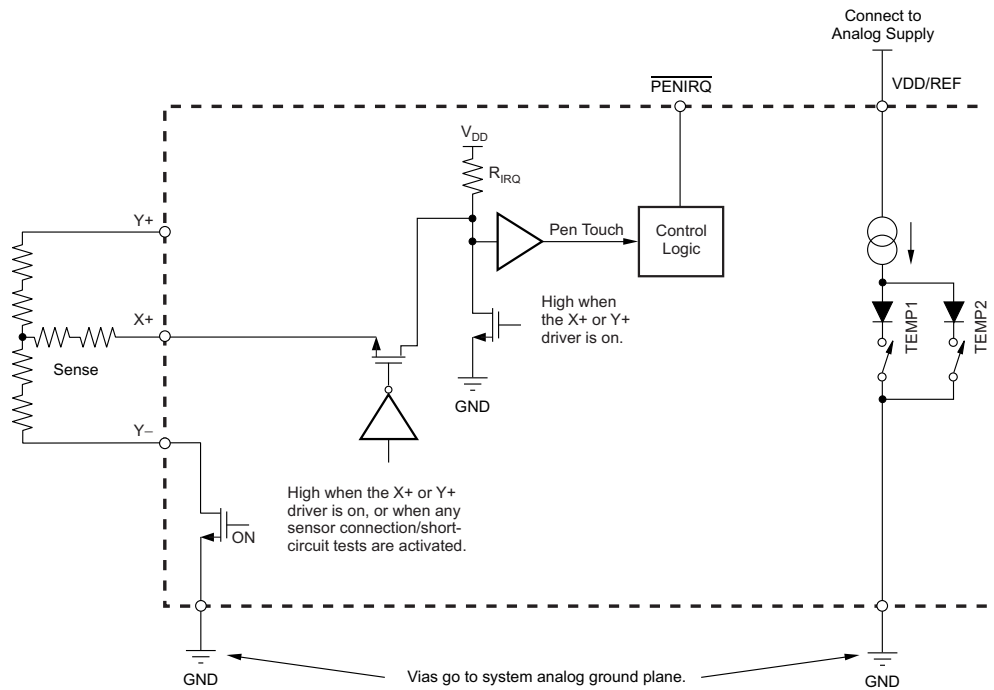

Copyright © 2016, Texas Instruments Incorporated

Figure 24. Example of a Pen-Touch Induced Interrupt Through the  $\overline{\text{PENIRQ}}$  Pin

7.3.3.9 Preprocessing

The TSC2007-Q1 has a combined MAV filter (median value filter and averaging filter).

7.3.3.9.1 MAV Filter

If the acquired signal source is noisy because of the digital switching circuit, it may necessary to evaluate the data without noise. In this case, the median value filter operation helps remove the *noise*. The array of seven converted results is sorted first. The middle three values are then averaged to produce the output value of the MAV filter.

The MAV filter is applied to all measurements for all analog inputs including the touch screen inputs, temperature measurements TEMP1 and TEMP2, and auxiliary input AUX. To shorten the conversion time, the MAV filter may be bypassed through the setup command; see [Table 4](#) and [Table 5](#).

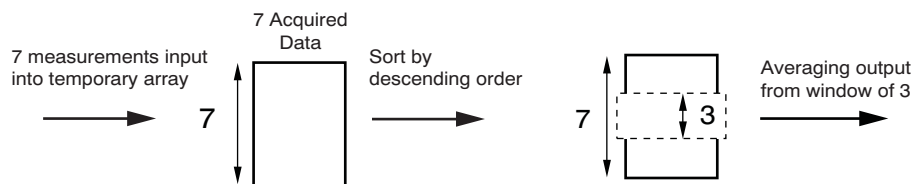

Figure 25. MAV Filter Operation (Patent Pending)

## 7.4 Device Functional Modes

### 7.4.1 Power-On Reset (POR)

During TSC2007-Q1 power up, an internal power-on reset (POR) is automatically implemented. The POR brings the TSC to the default working condition, and checks the A0 and A1 pins for the two LSBs of the I<sup>2</sup>C address. The TSC2007-Q1 senses the power-up curve to decide whether or not to implement a POR.

It is required to follow the power-on and power-off slope and interval requirements, as provided in [Electrical Characteristics](#), to ensure a proper POR of the TSC2007-Q1. Review [Important Considerations to Assure a Safe POR](#) to ensure a safe POR.

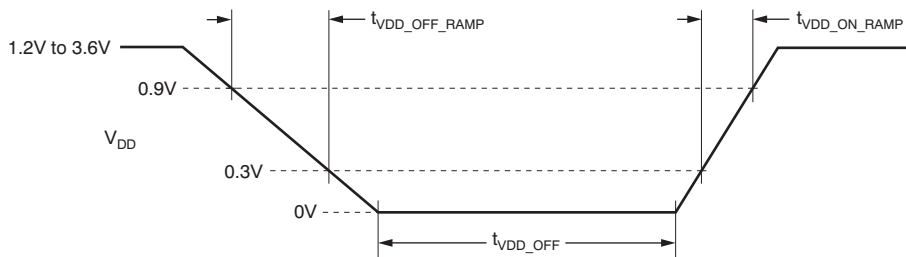

Figure 26. Power-On Reset Timing

Table 1. Timing Requirements for Figure 26

PARAMETER	TEST CONDITIONS	MIN	MAX	UNIT
V <sub>DD</sub> off ramp	T <sub>A</sub> = -40°C to 85°C	2		kV/s
V <sub>DD</sub> off time	T <sub>A</sub> = -40°C to 85°C, V <sub>DD</sub> = 0 V	1.2		s
	T <sub>A</sub> = -20°C to 85°C, V <sub>DD</sub> = 0 V	0.3		s
V <sub>DD</sub> on ramp	T <sub>A</sub> = -40°C to 85°C	12		kV/s

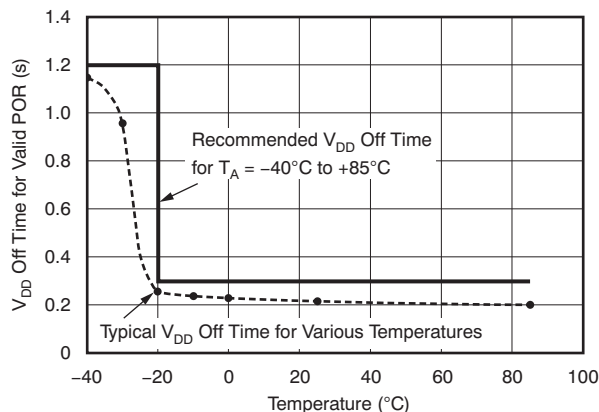

Figure 27. V<sub>DD</sub> Off Time vs Temperature

## 7.5 Programming

### 7.5.1 I<sup>2</sup>C Interface

The TSC2007-Q1 supports the I<sup>2</sup>C serial bus and data transmission protocol in all three defined modes: standard, fast, and high-speed. A device that sends data onto the bus is defined as a transmitter, and a device receiving data as a receiver. The device that controls the message is called a *master*. The devices that are controlled by the master are *slaves*. The bus must be controlled by a master device that generates the serial clock (SCL), controls the bus access, and generates the START and STOP conditions. The TSC2007-Q1 operates as a slave on the I<sup>2</sup>C bus. Connections to the bus are made through the open-drain I/O lines, SDA, and SCL.

## Programming (continued)

The following bus protocol has been defined (see [Figure 28](#)):

- Data transfer may be initiated only when the bus is not busy.
- During data transfer, the data line must remain stable whenever the clock line is HIGH. Changes in the data line while the clock line is HIGH are interpreted as control signals.

Accordingly, the following bus conditions have been defined:

**Bus Not Busy** Both data and clock lines remain HIGH.

**Start Data Transfer** A change in the state of the data line, from HIGH to LOW, while the clock is HIGH, defines a START condition.

**Stop Data Transfer** A change in the state of the data line, from LOW to HIGH, while the clock line is HIGH, defines the STOP condition.

**Data Valid** The state of the data line represents valid data, when, after a START condition, the data line is stable for the duration of the HIGH period of the clock signal. There is one clock pulse per bit of data.

Each data transfer is initiated with a START condition and terminated with a STOP condition. The number of data bytes transferred between START and STOP conditions is not limited and is determined by the master device. The information is transferred byte-wise and each receiver acknowledges with a ninth-bit.

Within the I<sup>2</sup>C bus specifications, a standard mode (100-kHz clock rate), a fast mode (400-kHz clock rate), and a high-speed mode (1.7-MHz or 3.4-MHz clock rate) are each defined. The TSC2007-Q1 works in all three modes.

**Acknowledge** Each receiving device, when addressed, is obliged to generate an acknowledge after the reception of each byte. The master device must generate an extra clock pulse that is associated with this acknowledge bit.

A device that acknowledges must pull down the SDA line during the acknowledge clock pulse in such a way that the SDA line is stable LOW during the HIGH period of the acknowledge clock pulse. Of course, setup and hold times must be taken into account. A master must signal an end of data to the slave by not generating an acknowledge bit on the last byte that has been clocked out of the slave. In this case, the slave must leave the data line HIGH to enable the master to generate the STOP condition.

[Figure 28](#) details how data transfer is accomplished on the I<sup>2</sup>C bus. Depending upon the state of the R/W bit, two types of data transfer are possible:

1. **Data transfer from a master transmitter to a slave receiver.** The first byte transmitted by the master is the slave address. Next follows a number of data bytes. The slave returns an acknowledge bit after the slave address and each received byte.
2. **Data transfer from a slave transmitter to a master receiver.** The first byte, the slave address, is transmitted by the master. The slave then returns an acknowledge bit. Next, a number of data bytes are transmitted by the slave to the master. The master returns an acknowledge bit after all received bytes other than the last byte. At the end of the last received byte, a not-acknowledge is returned.

The master device generates all of the serial clock pulses and the START and STOP conditions. A transfer ends with a STOP condition or a repeated START condition. Because a repeated START condition is also the beginning of the next serial transfer, the bus is not released.

## Programming (continued)

The TSC2007-Q1 may operate in the following two modes:

1. **Slave Receiver Mode:** Serial data and clock are received through SDA and SCL. After each byte is received, an acknowledge bit is transmitted. START and STOP conditions are recognized as the beginning and end of a serial transfer. Address recognition is performed by hardware after reception of the slave address and direction bit.
2. **Slave Transmitter Mode:** The first byte (the slave address) is received and handled as in the slave receiver mode. However, in this mode, the direction bit indicates that the transfer direction is reversed. Serial data are transmitted on SDA by the TSC2007-Q1 while the serial clock is input on SCL. START and STOP conditions are recognized as the beginning and end of a serial transfer.

### 7.5.1.1 I<sup>2</sup>C Fast or Standard Mode (F/S Mode)

In I<sup>2</sup>C Fast or Standard (F/S) mode, serial data transfer must meet the timing shown in the [Specifications](#) section.

In the serial transfer format of F/S mode, the master signals the beginning of a transmission to a slave with a START condition (S), which is a high-to-low transition on the SDA input while SCL is high. When the master has finished communicating with the slave, the master issues a STOP condition (P), which is a low-to-high transition on SDA while SCL is high, as shown in [Figure 28](#). The bus is free for another transmission after a STOP condition has occurred. [Figure 28](#) shows the complete F/S mode transfer on the I<sup>2</sup>C, 2-wire serial interface. The address byte, control byte, and data byte are transmitted between the START and STOP conditions. The SDA state is only allowed to change while SCL is low, except for the START and STOP conditions. Data are transmitted in 8-bit words. Nine clock cycles are required to transfer the data into or out of the device (8-bit word plus acknowledge bit).

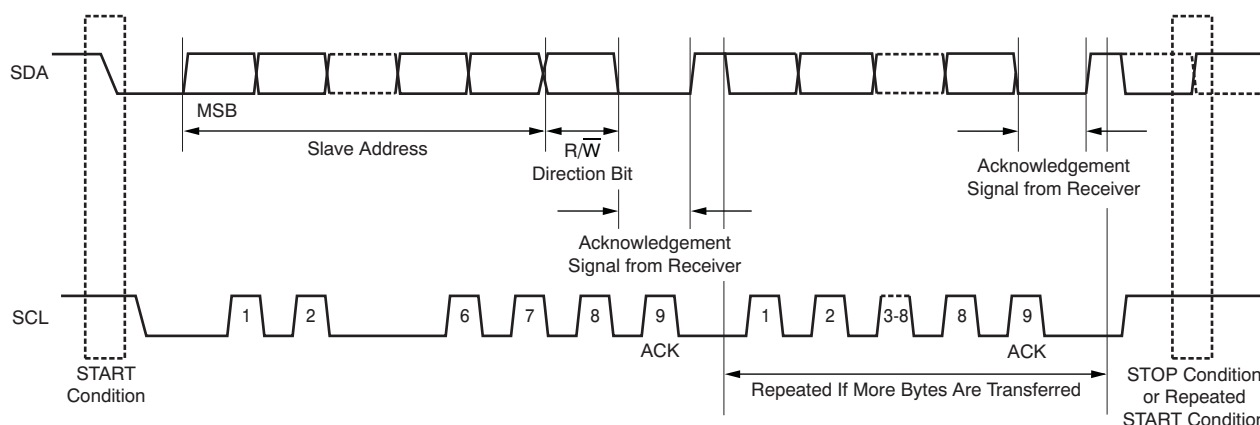

Figure 28. Complete Fast-Mode or Standard-Mode Transfer

### 7.5.1.2 I<sup>2</sup>C High-Speed Mode (HS Mode)

The TSC2007-Q1 can operate with high-speed I<sup>2</sup>C masters. To do so, the pullup resistor on SCL must be changed to an active pullup, as recommended in the I<sup>2</sup>C specification.

Serial data transfer format in High-Speed (HS) mode meets the Fast or Standard (F/S) mode I<sup>2</sup>C bus specification. HS mode can only commence after the following conditions (all of which are in F/S mode) exist:

1. START condition (S)
2. 8-bit master code (00001xxx)
3. Not-acknowledge bit (N)

[Figure 29](#) shows this sequence in more detail. HS-mode master codes are reserved 8-bit codes used only for triggering HS mode, and are not to be used for slave addressing or any other purpose. The master code indicates to other devices that an HS-mode transfer is about to begin and the connected devices must meet the HS-mode specification. Because no device is allowed to acknowledge the master code, the master code is followed by a not-acknowledge bit (N).

## Programming (continued)

After the not-acknowledge bit (N) and SCL have been pulled up to a HIGH level, the master switches to HS mode and enables the current-source pullup circuit for SCL (at time  $t_H$  shown in Figure 29). Because other devices can delay the serial transfer before  $t_H$  by stretching the LOW period of SCL, the master enables the current-source pullup circuit when all devices have released SCL, and SCL has reached a HIGH level, thus speeding up the last part of the rise time of the SCL.

The master then sends a repeated START condition (Sr) followed by a 7-bit slave address with a R/W bit address, and receives an acknowledge bit (A) from the selected slave. After a repeated START (Sr) condition and after each acknowledge bit (A) or not-acknowledge bit (N), the master disables its current-source pullup circuit. This disabling enables other devices, such as the TSC2007-Q1, to delay the serial transfer (until the converted data are stored in the TSC internal shift register) by stretching the LOW period of SCL. The master re-enables its current-source pullup circuit again when all devices have released SCL, and SCL reaches a HIGH level, which speeds up the last part of the SCL signal rise time.

Data transfer continues in HS mode after the next repeated START (Sr), and only switches back to F/S mode after a STOP condition (P). To reduce the overhead of the master code, it is possible for the master to link a number of HS-mode transfers, separated by repeated START conditions (Sr).

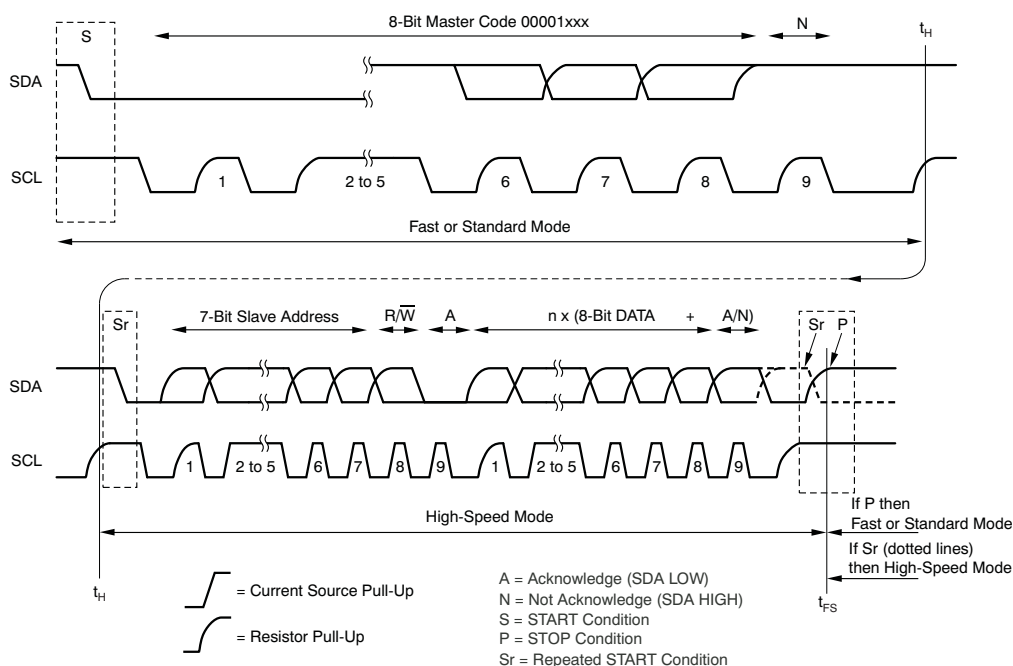

**Figure 29. Complete High-Speed Mode Transfer**

## 7.5.2 Digital Interface

### 7.5.2.1 Address Byte

The TSC2007-Q1 has a 7-bit slave address word. The first five bits (MSBs) of the slave address are factory-preset to comply with the I<sup>2</sup>C standard for A-D converters and are always set at 10010. The logic state of the address input pins (A1–A0) determines the two LSBs of the device address to activate communication. Therefore, a maximum of four devices with the same preset code can be connected on the same bus at one time.

The A1–A0 address inputs are read whenever an address byte is received, and must be connected to the supply pin (VDD/REF) or the ground pin (GND). The slave address is latched into the TSC2007-Q1 on the falling edge of SCL after the R/W bit has been received by the slave.

## Programming (continued)

The last bit of the address byte ( $R/\overline{W}$ ) defines the operation to be performed. When set to a 1, a read operation is selected; when set to a zero, a write operation is selected. Following the START condition, the TSC2007-Q1 monitors the SDA bus, checking the device type identifier being transmitted. Upon receiving the 10010 code, the appropriate device select bits, and the  $R/\overline{W}$  bit, the slave device outputs an acknowledge signal on the SDA line.

**Table 2. I<sup>2</sup>C Slave Address Byte**

MSB D7	D6	D5	D4	D3	D2	D1	LSB D0
1	0	0	1	0	A1	A0	$R/\overline{W}$

### Bit D0: $R/\overline{W}$

1: I<sup>2</sup>C master read from TSC (I<sup>2</sup>C read addressing).

0: I<sup>2</sup>C master write to TSC (I<sup>2</sup>C write addressing).

### 7.5.2.2 Command Byte

**Table 3. Command Byte Definition (Excluding the Setup Command)<sup>(1)</sup>**

BIT	NAME	DESCRIPTION
D7–D4	C3–C0	Converter function select bits: These bits select the input to be converted and the converter function to be executed, activate the drivers, and configure the PENIRQ pullup resistor ( $R_{IRQ}$ ). Table 4 lists the possible converter functions. All Converter Function Select bits as detailed in Table 4, except for the setup command (1011).
D3–D2	PD1–PD0	Power-down bits: These two bits select the power-down mode that the TSC2007-Q1 enters after the current command completes, as shown in Table 3. It is recommended to set PD0 = 0 in each command byte to get the lowest power consumption possible. If multiple X, Y, and Z position measurements are done one right after another (such as when averaging), PD0 = 1 leaves the touch screen drivers on at the end of each conversion cycle. 00: Power down between cycles. $\overline{PENIRQ}$ enabled. 01: A-D converter on. $\overline{PENIRQ}$ disabled. 10: A-D converter off. $\overline{PENIRQ}$ enabled. 11: A-D converter on. $\overline{PENIRQ}$ disabled.
D1	M	Mode bit 0: 12-bit (Lower speed referred to as the 2-MHz clock). 1: 8-bit (Higher speed referred to as the 4-MHz clock).
D0	X	Do not care.

(1) The command byte definition for the setup command is shown in Table 5.

When the TSC2007-Q1 powers up, the power-down bits must be written to ensure that the device is placed into the mode that achieves the lowest power. Therefore, immediately after power up, send a command byte that sets PD1 = PD0 = 0, so that the device is in the lowest power mode, powering down between conversions.

**Table 4. Converter Function Select**

C3	C2	C1	C0	FUNCTION	INPUT TO A-D CONVERTER	X-DRIVERS	Y-DRIVERS	ACK	REFERENCE MODE
0	0	0	0	Measure TEMP0	TEMP0	OFF	OFF	Y	Single-Ended
0	0	0	1	Reserved	—	OFF	OFF	N	Single-Ended
0	0	1	0	Measure AUX	AUX	OFF	OFF	Y	Single-Ended
0	0	1	1	Reserved	—	OFF	OFF	N	Single-Ended
0	1	0	0	Measure TEMP1	TEMP1	OFF	OFF	Y	Single-Ended
0	1	0	1	Reserved	—	OFF	OFF	N	Single-Ended
0	1	1	0	Reserved	—	OFF	OFF	N	Single-Ended
0	1	1	1	Reserved	—	OFF	OFF	N	Single-Ended
1	0	0	0	Activate X-drivers	—	ON	OFF	Y	Differential
1	0	0	1	Activate Y-drivers	—	OFF	ON	Y	Differential
1	0	1	0	Activate Y+, X-drivers	—	X– ON	Y+ ON	Y	Differential
1	0	1	1	Setup command <sup>(1)</sup>	—	OFF	OFF	N	—
1	1	0	0	Measure X position	Y+	ON	OFF	Y	Differential
1	1	0	1	Measure Y position	X+	OFF	ON	Y	Differential
1	1	1	0	Measure Z1 position	X+	X– ON	Y+ ON	Y	Differential
1	1	1	1	Measure Z2 position	Y–	X– ON	Y+ ON	Y	Differential

(1) The setup command has an additional four bits of data. These data are static; that is, they are not changed by other commands, except for the power-on reset. The default value for these bits after power-on reset is 0000. [Table 5](#) shows the definition of these data bits.

**Table 5. Command Byte Definition for the Setup Command**

BIT	NAME	DESCRIPTION
D7–D4	C3–C0	Setup command; must write <i>1011</i> .
D3–D2	PD1–PD0	Reserved; must write <i>00</i> .
D1	Filter control	0: Use the onboard MAV filter (default). 1: Bypass the onboard MAV filter.
D0	R <sub>IRQ</sub> select	$\overline{\text{PENIRQ}}$ pullup resistor (R <sub>IRQ</sub> ) select 0: R <sub>IRQ</sub> = 50 k $\Omega$ (default). 1: R <sub>IRQ</sub> = 90 k $\Omega$ .

### 7.5.2.3 Start a Converter Function or Write Cycle

A conversion or write cycle begins when the master issues the address byte containing the slave address of the TSC2007-Q1, with the eighth bit equal to a 0 ( $R/\overline{W} = 0$ ), as shown in [Table 2](#). Once the eighth bit has been received, and the address matches the A1–A0 address input pin setting, the TSC2007-Q1 issues an acknowledge.

When the master receives the acknowledge bit from the TSC2007-Q1, the master writes the command byte to the slave (see [Table 3](#)). After the command byte is received by the slave, the slave issues another acknowledge bit. The master then ends the write cycle by issuing a repeated START or a STOP condition, as shown in [Figure 30](#).

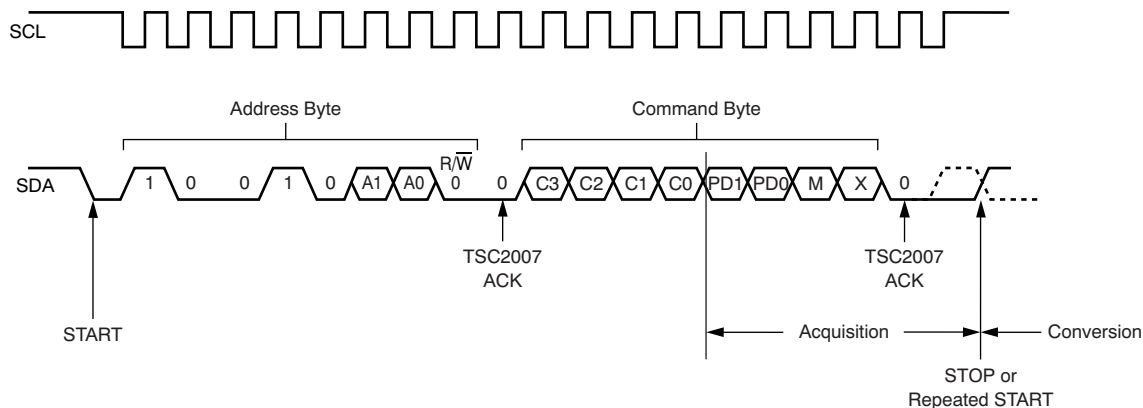

**Figure 30. Complete I<sup>2</sup>C Serial Write Transmission**

If the master sends additional command bytes after the initial byte, but before sending a STOP or repeated START condition, the TSC2007-Q1 does not acknowledge those bytes.

The input multiplexer channel for the A-D converter is selected when bits C3 through C0 are clocked in. If the selected channel is an X, Y, or Z position measurement, the appropriate drivers turn on once the acquisition period begins.

When  $R/\overline{W} = 0$ , the input sample acquisition period starts on the falling edge of SCL when the C0 bit of the command byte has been latched, and ends when a STOP or repeated START condition has been issued. A-D conversion starts immediately after the acquisition period. The multiplexer inputs to the A-D converter are disabled once the conversion period starts. However, if an X, Y, or Z position is being measured, the respective touch screen drivers remain on during the conversion period. A complete write cycle is shown in [Figure 30](#).

#### 7.5.2.4 Read a Conversion or Read Cycle

For best performance, the I<sup>2</sup>C bus must remain in an idle state while an A-D conversion is taking place. This idling prevents digital clock noise from affecting the bit decisions being made by the TSC2007-Q1. The master must wait for at least 10  $\mu$ s before attempting to read data from the TSC2007-Q1 to realize this best performance. However, the master does not need to wait for a completed conversion before beginning a read from the slave, if full 12-bit performance is not necessary.

Data access begins with the master issuing a START condition followed by the address byte (see [Table 2](#)) with  $R/\overline{W} = 1$ .

When the eighth bit has been received and the address matches, the slave issues an acknowledge. The first byte of serial data then follows (D11–D4, MSB first).

After the first byte has been sent by the slave, it releases the SDA line for the master to issue an acknowledge. The slave responds with the second byte of serial data upon receiving the acknowledge from the master (D3–D0, followed by four 0 bits). The second byte is followed by a NOT acknowledge bit (ACK = 1) from the master to indicate that the last data byte has been received. If the master somehow acknowledges the second data byte, invalid data are returned (FFh). This condition applies to both 12-bit and 8-bit modes. See [Figure 31](#) for a complete I<sup>2</sup>C read transmission.

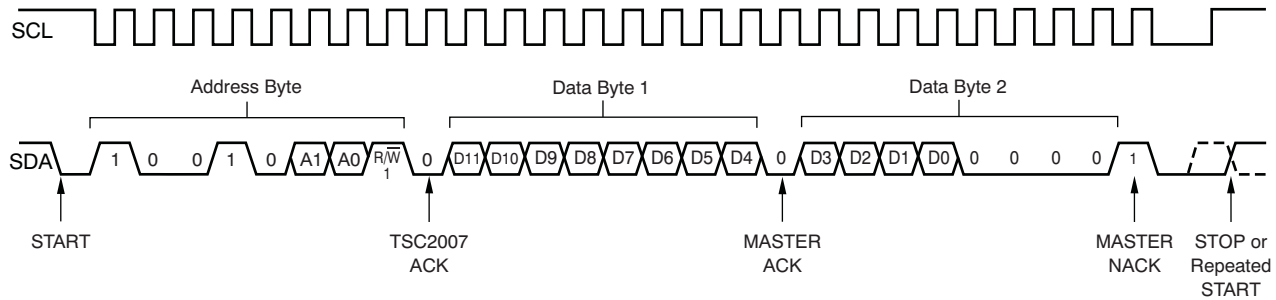

Figure 31. Complete I<sup>2</sup>C Serial Read Transmission

### 7.5.2.5 Throughput Rate and I<sup>2</sup>C Bus Traffic

Although the internal A-D converter has a sample rate of up to 200 kSPS, the throughput presented at the bus is much lower. The rate is reduced because preprocessing manages the redundant work of filtering out noise. The throughput is further limited by the I<sup>2</sup>C bus bandwidth. The effective throughput is approximately 20 kSPS at 8-bit resolution, or 10 kSPS at 12-bit resolution. This preprocessing saves a large portion of the I<sup>2</sup>C bandwidth for the system to use on other devices.

Each sample and conversion takes 19 CCLK cycles (12-bit), or 16 CCLK cycles (8-bit). For a typical internal 4-MHz OSC clock, the frequency actually ranges from 3.66 MHz to 3.82 MHz. For V<sub>DD</sub> = 1.2 V, the frequency reduces to 3.19 MHz, which gives a 3.19 MHz / 16 = 199 kSPS raw A-D converter sample rate.

#### 7.5.2.5.1 12-Bit Operation

For 12-bit operation, sending the conversion result across the I<sup>2</sup>C bus takes 49 bus clocks (SCL clock). Each write cycle takes 20 I<sup>2</sup>C cycles (START, STOP, address byte, 2 ACKs, and command byte). Each read cycle takes 29 I<sup>2</sup>C cycles (START, STOP, address byte, 3 ACKs, and data bytes 1 and 2). Seven sample-and-convert operations take 19 × 7 internal clocks to complete. The MAV filter loop requires 19 internal clocks. For V<sub>DD</sub> = 1.2 V, the complete processed data cycle time calculations are shown in Table 6. Because the first acquisition cycle overlaps with the I/O cycle, four CCLKs must be deducted from the total CCLK cycles. For 12-bit mode, (19 × 7 + 19) – 4 = 148 CCLKs plus I/O are required.

#### 7.5.2.5.2 8-Bit Operation

For 8-bit operation, sending the conversion result across the I<sup>2</sup>C bus takes 40 bus clocks (SCL clock). Each write cycle takes 20 I<sup>2</sup>C cycles (START, STOP, address byte, 2 ACKs, and command byte). Each read cycle takes 20 I<sup>2</sup>C cycles (START, STOP, address byte, 2 ACKs, and data byte 1). Seven sample-and-convert operations takes 16 × 7 internal clocks to complete. The MAV filter loop requires 19 internal clocks. For V<sub>DD</sub> = 1.2 V, the complete processed data cycle time calculations are shown in Table 6. Because the first acquisition cycle overlaps with the I/O cycle, four CCLKs must be deducted from the total CCLK cycles. For 8-bit mode, (16 × 7 + 19) – 4 = 127 CCLKs plus I/O are required.

Table 6. Measurement Cycle Time Calculations

STANDARD MODE: 100 kHz (Period = 10 μs)	
8-Bit	40 × 10 μs + 127 × 313 ns = 439.8 μs (2.27 kSPS through the I <sup>2</sup> C bus)
12-Bit	49 × 10 μs + 148 × 625 ns = 582.5 μs (1.72 kSPS through the I <sup>2</sup> C bus)
FAST MODE: 400 kHz (Period = 2.5 μs)	
8-Bit	40 × 2.5 μs + 127 × 313 ns = 139.8 μs (7.15 kSPS through the I <sup>2</sup> C bus)
12-Bit	49 × 2.5 μs + 148 × 625 ns = 215 μs (4.65 kSPS through the I <sup>2</sup> C bus)
HIGH-SPEED MODE: 1.7 MHz (Period = 588 ns)	
8-Bit	40 × 588 ns + 127 × 313 ns = 63.3 μs (15.79 kSPS through the I <sup>2</sup> C bus)
12-Bit	49 × 588 ns + 148 × 625 ns = 121.3 μs (8.24 kSPS through the I <sup>2</sup> C bus)
HIGH-SPEED MODE: 3.4 MHz (Period = 294 ns)	
8-Bit	40 × 294 ns + 127 × 313 ns = 51.6 μs (19.39 kSPS through the I <sup>2</sup> C bus)
12-Bit	49 × 294 ns + 148 × 625 ns = 106.9 μs (9.35 kSPS through the I <sup>2</sup> C bus)

As an example, use  $V_{DD} = 1.2\text{ V}$  and 12-bit mode with the Fast-mode I<sup>2</sup>C clock ( $f_{SCL} = 400\text{ kHz}$ ). The equivalent TSC throughput is at least seven times faster than the effective throughput across the bus ( $4.65\text{ k} \times 7 = 32.55\text{ kSPS}$ ). The supply current to the TSC for this rate and configuration is  $128\text{ }\mu\text{A}$ . To achieve an equivalent sample throughput of  $8.2\text{ kSPS}$  using the device without preprocessing, the TSC2007-Q1 consumes only  $(8.2\text{ or }32.55) \times 128\text{ }\mu\text{A} = 32.24\text{ }\mu\text{A}$ .

**Table 7. Effective and Equivalent Throughput Rates**

SUPPLY VOLTAGE	I <sup>2</sup> C BUS SPEED ( $f_{SCL}$ )	RESOLUTION	TSC CONVERSION CYCLE TIME ( $\mu\text{s}$ )	EFFECTIVE THROUGHPUT (kSPS)	EQUIVALENT THROUGHPUT (kSPS)	SCL CYCLES	CCLK CYCLES	$f_{CCLK}$ (kHz)	CCLK PERIODS (ns)
2.7 V	100 kHz Standard	8-bit	433.6	2.31	16.14	40	127	3780	264.6
		12-bit	568.7	1.76	12.31	49	148	1880	531.9
	400 kHz Fast	8-bit	133.6	7.49	52.4	40	127	3780	264.6
		12-bit	201.2	4.97	34.79	49	148	1880	531.9
	1.7 MHz High-Speed	8-bit	57.1	17.5	122.53	40	127	3780	264.6
		12-bit	107.5	9.3	65.09	49	148	1880	531.9
3.4 MHz High-Speed	8-bit	45.4	22.04	154.31	40	127	3780	264.6	
	12-bit	93.1	10.74	75.16	49	148	1880	531.9	
1.8 V	100 kHz Standard	8-bit	434.7	2.3	16.1	40	127	3660	273.2
		12-bit	570.9	1.75	12.26	49	148	1830	546.4
	400 kHz Fast	8-bit	134.7	7.42	51.97	40	127	3660	273.2
		12-bit	203.4	4.92	34.42	49	148	1830	546.4
	1.7 MHz High-Speed	8-bit	58.2	17.17	120.22	40	127	3660	273.2
		12-bit	109.7	9.12	63.81	49	148	1830	546.4
3.4 MHz High-Speed	8-bit	46.5	21.52	150.65	40	127	3660	273.2	
	12-bit	95.3	10.49	73.46	49	148	1830	546.4	
1.2 V	100 kHz Standard	8-bit	439.8	2.27	15.92	40	127	3190	313.5
		12-bit	582.5	1.72	12.02	49	148	1600	625
	400 kHz Fast	8-bit	139.8	7.15	50.07	40	127	3190	313.5
		12-bit	215	4.65	32.56	49	148	1600	625
	1.7 MHz High-Speed	8-bit	63.3	15.79	110.51	40	127	3190	313.5
		12-bit	121.3	8.24	57.7	49	148	1600	625
3.4 MHz High-Speed	8-bit	51.6	19.39	135.72	40	127	3190	313.5	
	12-bit	106.9	9.35	65.47	49	148	1600	625	

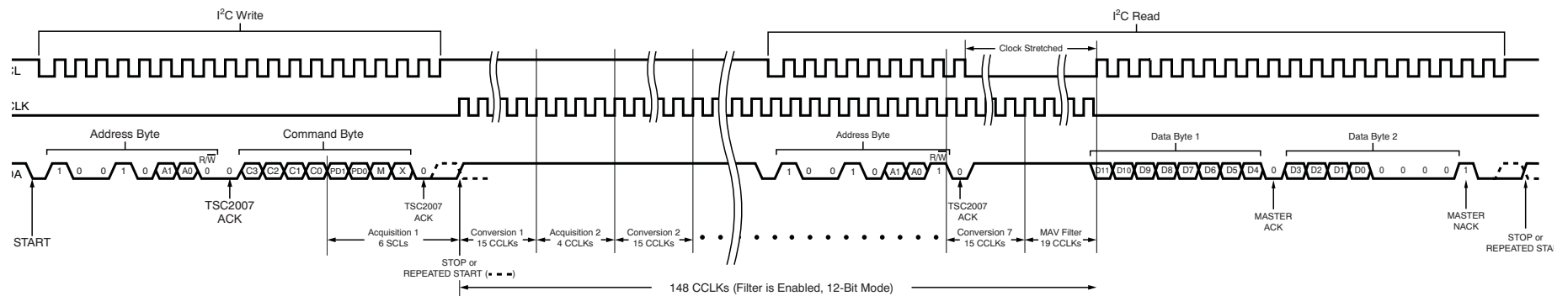

Figure 32. Data Acquisition Cycle (Filter Enabled)

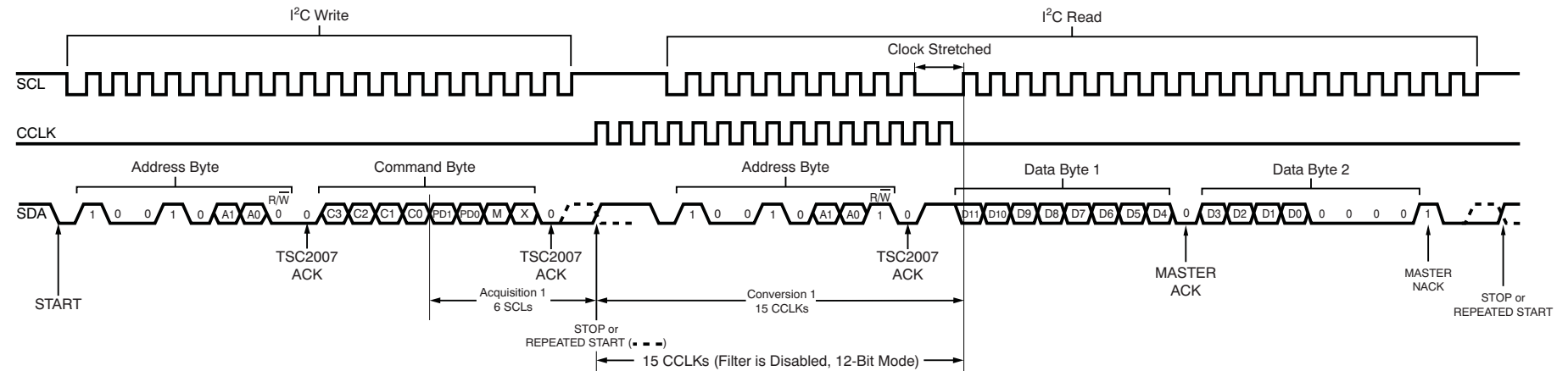

Figure 33. Data Acquisition Cycle (Filter Disabled)

## 8 Application and Implementation

### NOTE

Information in the following applications sections is not part of the TI component specification, and TI does not warrant its accuracy or completeness. TI's customers are responsible for determining suitability of components for their purposes. Customers should validate and test their design implementation to confirm system functionality.

### 8.1 Application Information

The TSC2007-Q1 is designed for use in automotive touch-screen displays. It supports resistive 4-wire touch screens that can be used in the head unit for infotainment and navigation displays. The auxiliary input can be used for external temperature sensing, ambient light monitoring for back-lighting control, or for current monitoring.

### 8.2 Typical Application

A typical application of the TSC2007-Q1 is shown in [Figure 34](#).

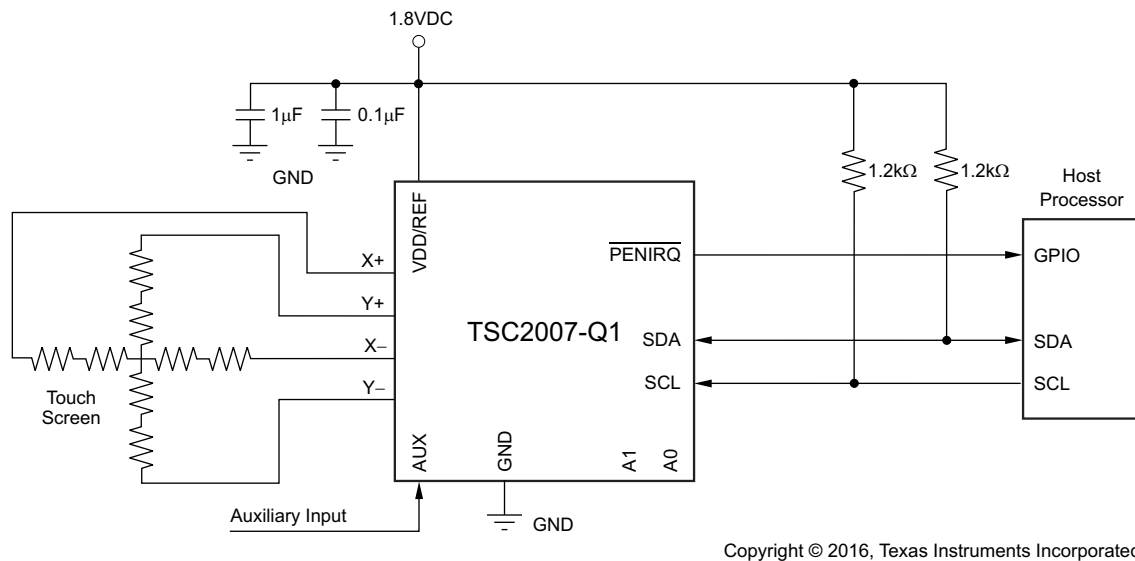

**Figure 34. Typical Circuit Configuration**

#### 8.2.1 Design Requirements

The system-level requirements for this design include:

- Normal 4-wire resistive touch screen
- To achieve the best SNR, select the highest operating voltage of the TSC2007-Q1 device that is compatible with the system.

#### 8.2.2 Detailed Design Procedure

##### 8.2.2.1 4-Wire Touch Screen Coordinate Pair Measurement

A 4-wire touch screen is typically constructed as shown in [Figure 35](#). It consists of two transparent resistive layers separated by insulating spacers.

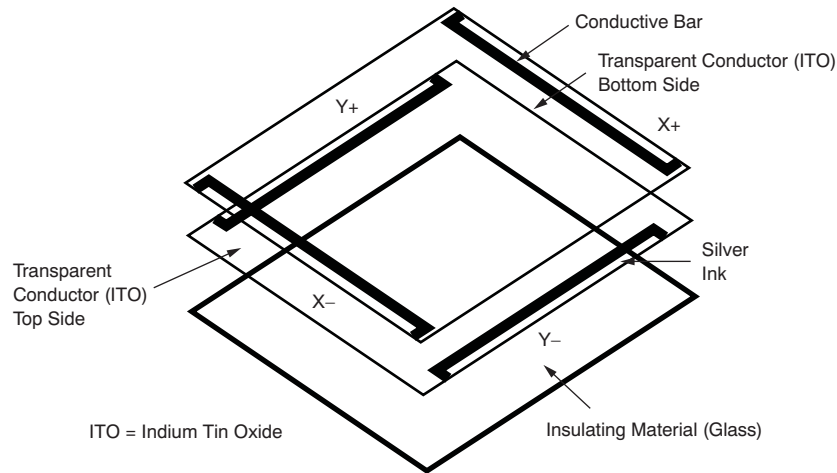
**Typical Application (continued)**

**Figure 35. 4-Wire Touch Screen Construction**

The 4-wire touch screen panel works by applying a voltage across the vertical or horizontal resistive network. The A-D converter converts the voltage measured at the point where the panel is touched. A measurement of the Y position of the pointing device is made by connecting the X+ input to a data converter chip, turning on the Y+ and Y– drivers, and digitizing the voltage seen at the X+ input. The voltage measured is determined by the voltage divider developed at the point of touch. For this measurement, the horizontal panel resistance in the X+ lead does not affect the conversion because of the high input impedance of the A-D converter.

Voltage is then applied to the other axis, and the A-D converter converts the voltage representing the X position on the screen. This process provides the X and Y coordinates to the associated processor.

Measuring touch pressure (Z) can also be done with the TSC2007-Q1. To determine pen or finger touch, the pressure of the *touch* must be determined. Generally, it is not necessary to have very high performance for this test; therefore, 8-bit resolution mode may be sufficient (however, data sheet calculations are shown using the 12-bit resolution mode). There are several different ways of performing this measurement. The TSC2007-Q1 supports two methods. The first method requires knowing the X-plate resistance, the measurement of the X position, and two additional cross panel measurements ( $Z_2$  and  $Z_1$ ) of the touch screen (see [Figure 36](#)). [Equation 3](#) calculates the touch resistance:

$$R_{\text{TOUCH}} = R_{X\text{-plate}} \times \frac{X_{\text{Position}}}{4096} \left( \frac{Z_2}{Z_1} - 1 \right) \quad (3)$$

The second method requires knowing both the X-plate and Y-plate resistance, measurement of X position and Y position, and  $Z_1$ . [Equation 4](#) also calculates the touch resistance:

$$R_{\text{TOUCH}} = \frac{R_{X\text{-plate}} \times X_{\text{Position}}}{4096} \left( \frac{4096}{Z_1} - 1 \right) - R_{Y\text{-plate}} \times \left( 1 - \frac{Y_{\text{Position}}}{4096} \right) \quad (4)$$

Typical Application (continued)

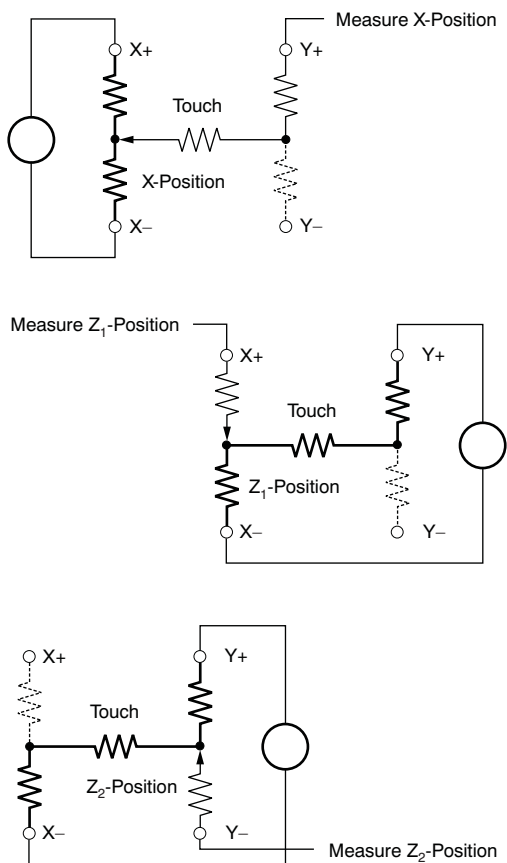

Figure 36. Pressure Measurement

When the touch panel is pressed or touched and the drivers to the panel are turned on, the voltage across the touch panel often overshoots and then slowly settles down (decays) to a stable DC value. This effect is a result of mechanical bouncing caused by vibration of the top layer sheet of the touch panel when the panel is pressed. This settling time must be accounted for, or else the converted value is incorrect. Therefore, a delay must be introduced between the time the driver for a particular measurement is turned on, and the time a measurement is made.

In some applications, external capacitors may be required across the touch screen for filtering noise picked up by the touch screen (noise generated by the LCD panel or back-light circuitry). The value of these capacitors provides a low-pass filter to reduce the noise, but creates an additional settling time requirement when the panel is touched. The settling time typically shows up as gain error.

To solve this problem, the TSC2007-Q1 can be commanded to turn on the drivers only, without performing a conversion. Time can then be allowed to perform a conversion before the command is issued.

The TSC2007-Q1 touch screen interface can measure position (X, Y) and pressure (Z).

8.2.2.2 Touch-Panel Driving Power

On a resistive touch-screen system, the driving current of the touch panel, provided by the TSC device through the analog interface, has the highest impact on the power consumption in the touch screen system. This touch-panel power consumption is decided by the resistance of the touch panel and the TSC power-supply ( $V_{DD}$ ) voltage. Figure 37 shows this relationship. The touch screen is driven by the TSC from the  $V_{DD}$  supply and the resistance of the panel determines the peak drive current.

## Typical Application (continued)

Figure 37 only shows the ideal TSC driving condition where the internal resistance of the TSC is ignored because the resistance is small (5 to 6  $\Omega$ ) compared to the resistance of the touch panel (hundreds to thousands of  $\Omega$ ). Therefore the actual power consumption may be less than that shown in Figure 37.

A user can reduce power consumption in three ways:

- Using touch screens with higher resistance
- Using a low-power supply ( $V_{DD}$ ) to the TSC
- Reducing the driver on-time or the on-off ratio of the driver

Touch panels with higher resistance are likely to cause more noise and longer settling time which limits the options for users.

The TSC2007-Q1 device is designed with a power supply ( $V_{DD}$ ) range from 1.2 V to 3.6 V.

### 8.2.3 Application Curve

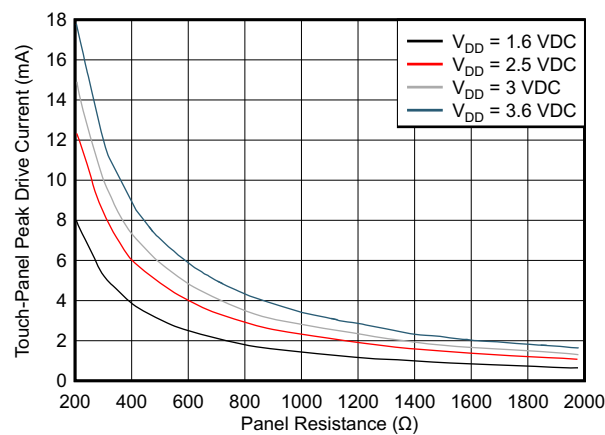

**Figure 37. Touch-Panel Power Consumption**

## 9 Power Supply Recommendations

This device is designed to operate from an input voltage supply of 1.2 V to 3.6 V. Power to the TSC2007-Q1 device must be clean and well bypassed. Add a 0.1- $\mu$ F ceramic capacitor between VDD/REF and GND.

## 10 Layout

### 10.1 Layout Guidelines

The following layout suggestions may allow optimum performance from the TSC2007-Q1. Keep in mind that many portable applications have conflicting requirements for power, cost, size, and weight. In general, most portable devices have fairly clean power and grounds because most of the internal components are very low power. This situation would mean less bypassing for the converter power and less concern regarding grounding. However, each situation is unique and the following suggestions must be reviewed carefully.

For optimum performance, take care of the physical layout of the TSC2007-Q1 circuitry. The basic SAR architecture is sensitive to glitches or sudden changes on the power supply, reference, ground connections, and digital inputs that occur immediately before latching the output of the analog comparator. Therefore, during any single conversion for an  $n$ -bit SAR converter, there are  $n$  windows in which large external transient voltages can easily affect the conversion result. Such glitches might originate from switching power supplies, nearby digital logic, and high power devices. The degree of error in the digital output depends on the reference voltage, layout, and the exact timing of the external event. The error can change if the external event changes in time with respect to the SCL input.

With this consideration in mind, power to the TSC2007-Q1 must be clean and well bypassed. A 0.1- $\mu$ F ceramic bypass capacitor must be placed as close to the device as possible. In addition, a 1- $\mu$ F to 10- $\mu$ F capacitor may also be required if the impedance of the connection between VDD/REF and the power supply is high.

A bypass capacitor is generally not required on the VDD/REF pin because the internal reference is buffered by an internal op amp. If an external reference voltage originates from an op amp, make sure that it can drive any bypass capacitor that is used without oscillation.

The TSC2007-Q1 architecture offers no inherent rejection of noise or voltage variation with regard to using an external reference input, which is of particular concern when the reference input is tied to the power supply. Any noise and ripple from the supply appears directly in the digital results. While high-frequency noise can be filtered out, voltage variation because of line frequency (50 Hz or 60 Hz) can be difficult to remove. Some package options have pins labeled as VOID. Avoid any active trace going under any pin marked as VOID unless it is shielded by a ground or power plane.

The GND pin must be connected to a clean ground point. In many cases, this point is the analog ground. Avoid connections that are too near the grounding point of a microcontroller or digital signal processor. If required, run a ground trace directly from the converter to the power-supply entry or battery connection point. The ideal layout includes an analog ground plane dedicated to the converter and associated analog circuitry.

In the specific case of use with a resistive touch screen, take care with the connection between the converter and the touch screen. Resistive touch screens have fairly low resistance; therefore, the interconnection must be as short and robust as possible. Loose connections can be a source of error when the contact resistance changes with flexing or vibrations.

As indicated previously, noise can be a major source of error in touch-screen applications (for example, applications that require a back-lit LCD panel). This electromagnetic interference (EMI) noise can be coupled through the LCD panel to the touch screen and cause flickering of the converted A-D converter data. Several things can be done to reduce this error, such as using a touch screen with a bottom-side metal layer connected to ground, which couples the majority of noise to ground. Additionally, filtering capacitors, from Y+, Y-, X+, and X- to ground, can also help. However, the use of these capacitors increases screen settling time and requires a longer time for panel voltages to stabilize. The resistor value varies depending on the touch screen sensor used. The PENIRQ pullup resistor ( $R_{IRQ}$ ) may be adequate for most of sensors.

TSC2007-Q1

ZHCS084A –SEPTEMBER 2011–REVISED DECEMBER 2016

www.ti.com.cn

10.2 Layout Example

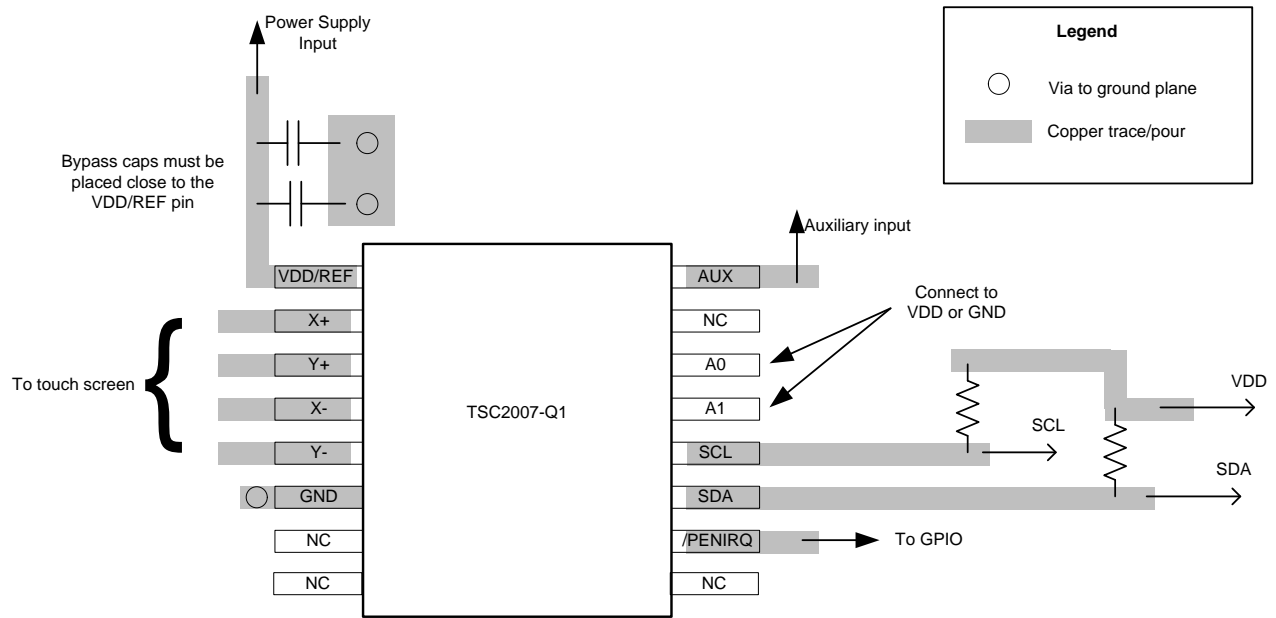

Figure 38. Example Layout for TSC2007-Q1

## 11 器件和文档支持

### 11.1 器件支持

#### 11.1.1 开发支持

如需开发支持，请参阅以下文档：

《TSC2003-Q1 汽车 I2C 触摸屏控制器》

### 11.2 文档支持

#### 11.2.1 相关文档

请参阅如下相关文档：

《关于确保安全 POR 的重要注意事项》(SBAA161)

### 11.3 接收文档更新通知

要接收文档更新通知，请转至 TI.com 上的器件产品文件夹。单击右上角的通知我 进行注册，即可每周接收产品信息更改摘要。有关更改的详细信息，请查看任何已修订文档中包含的修订历史记录。

### 11.4 社区资源

下列链接提供到 TI 社区资源的连接。链接的内容由各个分销商“按照原样”提供。这些内容并不构成 TI 技术规范，并且不一定反映 TI 的观点；请参阅 TI 的《使用条款》。

**TI E2E™ 在线社区** TI 的工程师对工程师 (E2E) 社区。此社区的创建目的在于促进工程师之间的协作。在 e2e.ti.com 中，您可以咨询问题、分享知识、拓展思路并与同行工程师一道帮助解决问题。

**设计支持** TI 参考设计支持 可帮助您快速查找有帮助的 E2E 论坛、设计支持工具以及技术支持的联系信息。

### 11.5 商标

E2E is a trademark of Texas Instruments.

All other trademarks are the property of their respective owners.

### 11.6 静电放电警告



ESD 可能会损坏该集成电路。德州仪器 (TI) 建议通过适当的预防措施处理所有集成电路。如果不遵守正确的处理措施和安装程序，可能会损坏集成电路。

ESD 的损坏小至导致微小的性能降级，大至整个器件故障。精密的集成电路可能更容易受到损坏，这是因为非常细微的参数更改都可能会导致器件与其发布的规格不相符。

### 11.7 Glossary

**SLYZ022** — TI Glossary.

This glossary lists and explains terms, acronyms, and definitions.

## 12 机械、封装和可订购信息

以下页面包含机械、封装和可订购信息。这些信息是指定器件的最新可用数据。这些数据如有变更，恕不另行通知和修订此文档。如欲获取此产品说明书的浏览器版本，请参阅左侧的导航。

**PACKAGING INFORMATION**

Orderable Device	Status (1)	Package Type	Package Drawing	Pins	Package Qty	Eco Plan (2)	Lead/Ball Finish (6)	MSL Peak Temp (3)	Op Temp (°C)	Device Marking (4/5)	Samples
TSC2007IPWRQ1	ACTIVE	TSSOP	PW	16	2000	Green (RoHS & no Sb/Br)	CU NIPDAU	Level-3-260C-168 HR	-40 to 85	TS2007I	Samples

(1) The marketing status values are defined as follows:

**ACTIVE:** Product device recommended for new designs.

**LIFEBUY:** TI has announced that the device will be discontinued, and a lifetime-buy period is in effect.

**NRND:** Not recommended for new designs. Device is in production to support existing customers, but TI does not recommend using this part in a new design.

**PREVIEW:** Device has been announced but is not in production. Samples may or may not be available.

**OBSELETE:** TI has discontinued the production of the device.

(2) **RoHS:** TI defines "RoHS" to mean semiconductor products that are compliant with the current EU RoHS requirements for all 10 RoHS substances, including the requirement that RoHS substance do not exceed 0.1% by weight in homogeneous materials. Where designed to be soldered at high temperatures, "RoHS" products are suitable for use in specified lead-free processes. TI may reference these types of products as "Pb-Free".

**RoHS Exempt:** TI defines "RoHS Exempt" to mean products that contain lead but are compliant with EU RoHS pursuant to a specific EU RoHS exemption.

**Green:** TI defines "Green" to mean the content of Chlorine (Cl) and Bromine (Br) based flame retardants meet JS709B low halogen requirements of <=1000ppm threshold. Antimony trioxide based flame retardants must also meet the <=1000ppm threshold requirement.

(3) MSL, Peak Temp. - The Moisture Sensitivity Level rating according to the JEDEC industry standard classifications, and peak solder temperature.

(4) There may be additional marking, which relates to the logo, the lot trace code information, or the environmental category on the device.

(5) Multiple Device Markings will be inside parentheses. Only one Device Marking contained in parentheses and separated by a "~" will appear on a device. If a line is indented then it is a continuation of the previous line and the two combined represent the entire Device Marking for that device.

(6) Lead/Ball Finish - Orderable Devices may have multiple material finish options. Finish options are separated by a vertical ruled line. Lead/Ball Finish values may wrap to two lines if the finish value exceeds the maximum column width.

**Important Information and Disclaimer:**The information provided on this page represents TI's knowledge and belief as of the date that it is provided. TI bases its knowledge and belief on information provided by third parties, and makes no representation or warranty as to the accuracy of such information. Efforts are underway to better integrate information from third parties. TI has taken and continues to take reasonable steps to provide representative and accurate information but may not have conducted destructive testing or chemical analysis on incoming materials and chemicals. TI and TI suppliers consider certain information to be proprietary, and thus CAS numbers and other limited information may not be available for release.

In no event shall TI's liability arising out of such information exceed the total purchase price of the TI part(s) at issue in this document sold by TI to Customer on an annual basis.

**OTHER QUALIFIED VERSIONS OF TSC2007-Q1 :**

- Catalog: [TSC2007](#)

NOTE: Qualified Version Definitions:

- Catalog - TI's standard catalog product

## TAPE AND REEL INFORMATION



### QUADRANT ASSIGNMENTS FOR PIN 1 ORIENTATION IN TAPE



\*All dimensions are nominal

Device	Package Type	Package Drawing	Pins	SPQ	Reel Diameter (mm)	Reel Width W1 (mm)	A0 (mm)	B0 (mm)	K0 (mm)	P1 (mm)	W (mm)	Pin1 Quadrant
TSC2007IPWRQ1	TSSOP	PW	16	2000	330.0	12.4	6.9	5.6	1.6	8.0	12.0	Q1

TAPE AND REEL BOX DIMENSIONS



\*All dimensions are nominal

Device	Package Type	Package Drawing	Pins	SPQ	Length (mm)	Width (mm)	Height (mm)
TSC2007IPWRQ1	TSSOP	PW	16	2000	367.0	367.0	35.0



4220204/A 02/2017

NOTES:

1. All linear dimensions are in millimeters. Any dimensions in parenthesis are for reference only. Dimensioning and tolerancing per ASME Y14.5M.
2. This drawing is subject to change without notice.
3. This dimension does not include mold flash, protrusions, or gate burrs. Mold flash, protrusions, or gate burrs shall not exceed 0.15 mm per side.
4. This dimension does not include interlead flash. Interlead flash shall not exceed 0.25 mm per side.
5. Reference JEDEC registration MO-153.

# EXAMPLE BOARD LAYOUT

PW0016A

TSSOP - 1.2 mm max height

SMALL OUTLINE PACKAGE



LAND PATTERN EXAMPLE  
EXPOSED METAL SHOWN  
SCALE: 10X



SOLDER MASK DETAILS

4220204/A 02/2017

NOTES: (continued)

- 6. Publication IPC-7351 may have alternate designs.
- 7. Solder mask tolerances between and around signal pads can vary based on board fabrication site.

# EXAMPLE STENCIL DESIGN

PW0016A

TSSOP - 1.2 mm max height

SMALL OUTLINE PACKAGE



SOLDER PASTE EXAMPLE  
BASED ON 0.125 mm THICK STENCIL  
SCALE: 10X

4220204/A 02/2017

NOTES: (continued)

8. Laser cutting apertures with trapezoidal walls and rounded corners may offer better paste release. IPC-7525 may have alternate design recommendations.
9. Board assembly site may have different recommendations for stencil design.

## 重要声明和免责声明

TI 均以“原样”提供技术性 & 可靠性数据（包括数据表）、设计资源（包括参考设计）、应用或其他设计建议、网络工具、安全信息和其他资源，不保证其中不含任何瑕疵，且不做任何明示或暗示的担保，包括但不限于对适销性、适合某特定用途或不侵犯任何第三方知识产权的暗示担保。

所述资源可供专业开发人员应用 TI 产品进行设计使用。您将对以下行为独自承担全部责任：(1) 针对您的应用选择合适的 TI 产品；(2) 设计、验证并测试您的应用；(3) 确保您的应用满足相应标准以及任何其他安全、安保或其他要求。所述资源如有变更，恕不另行通知。TI 对您使用所述资源的授权仅限于开发资源所涉及 TI 产品的相关应用。除此之外不得复制或展示所述资源，也不提供其它 TI 或任何第三方的知识产权授权许可。如因使用所述资源而产生任何索赔、赔偿、成本、损失及债务等，TI 对此概不负责，并且您须赔偿由此对 TI 及其代表造成的损害。

TI 所提供产品均受 TI 的销售条款 (<http://www.ti.com.cn/zh-cn/legal/termsofsale.html>) 以及 [ti.com.cn](http://www.ti.com.cn) 上或随附 TI 产品提供的其他可适用条款的约束。TI 提供所述资源并不扩展或以其他方式更改 TI 针对 TI 产品所发布的可适用的担保范围或担保免责声明。

邮寄地址：上海市浦东新区世纪大道 1568 号中建大厦 32 楼，邮政编码：200122  
Copyright © 2018 德州仪器半导体技术（上海）有限公司