

具有 2.5V 和 3.3V 输出的 CDCE813-Q1 可编程 1-PLL 时钟合成器和抖动消除器

1 特性

- 符合汽车类 标准
- 具有符合 AEC-Q100 标准的下列特性：
 - 器件温度 2 级：-40°C 至 105°C 的环境运行温度范围
 - 器件人体放电模式 (HBM) 静电放电 (ESD) 分类等级 H2
 - 器件 CDM ESD 分类等级 C6
- 系统内可编程性和 EEPROM
 - 串行可编程易失性寄存器
 - 非易失性 EEPROM 以存储客户设置
- 灵活的输入计时理念
 - 外部晶振：8MHz 至 32MHz
 - 单端低电压互补金属氧化物半导体 (LVCMOS) 高达 160MHz
- 高达 230MHz 可自由选择的输出频率
- 低噪声 PLL 内核
 - 集成了 PLL 环路滤波器组件
 - 低周期抖动（典型值为 50ps）
- 1.8V 器件电源（内核电压）
- 独立的输出电源引脚
 - CDCE813-Q1：3.3V 和 2.5V
- 灵活的时钟驱动器
 - 3 个用户可定义的控制输入 [S0、S1、S2]，例如，展频时钟 (SSC) 选择、频率切换、输出使能或掉电
 - 为视频、音频、USB、IEEE1394、RFID、Bluetooth®、WLAN、以太网和 GPS 生成高精度的时钟
 - 使用 TIDaVinci™，OMAP™，DSP 生成共同时钟频率
 - 可编程 SSC 调制
 - 启用 0-PPM 时钟生成
- 采用薄型小外形尺寸 (TSSOP) 封装
- 用于实现简便 PLL 设计和编程的开发和编程套件 (TI Pro-Clock™)

2 应用

- 仪表组
- 音响主机
- 导航系统
- 先进的驾驶员辅助系统 (ADAS)

3 说明

CDCE813-Q1 器件是一款基于模块化锁相环 (PLL) 的低成本、高性能、可编程时钟合成器。它们最多可从单个输入频率中生成 3 个输出时钟。借助集成的可配置 PLL，可在系统内针对任何时钟频率（高达 230MHz）对每个输出进行编程。

CDCE813-Q1 具有独立的输出电源引脚 V_{DDOUT} ，可提供 2.5V 至 3.3V 电压。

此输入接受外部晶振或 LVCMOS 时钟信号。凭借可选片载 VCXO，可将输出频率与外部控制信号同步。

PLL 支持 SSC（扩频时钟），从而改善抗电磁干扰 (EMI) 性能。

器件信息⁽¹⁾

器件型号	封装	封装尺寸 (标称值)
CDCE813QPWRQ1	TSSOP (14)	5.00mm × 4.40mm

(1) 如需了解所有可用封装，请参阅数据表末尾的可订购产品附录。

典型应用原理图

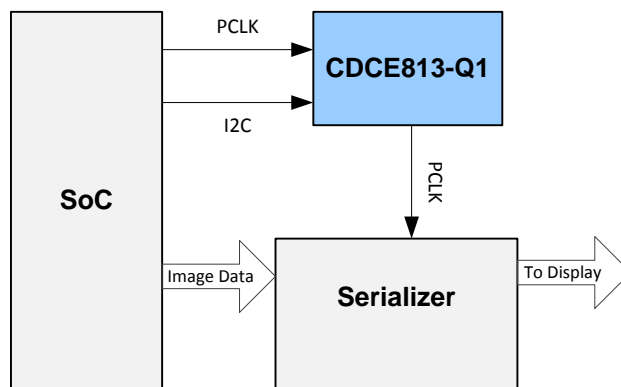

Copyright © 2017, Texas Instruments Incorporated



目录

1	特性	1	9.3	Feature Description	11
2	应用	1	9.4	Device Functional Modes	13
3	说明	1	9.5	Programming	14
4	修订历史记录	2	9.6	Register Maps	15
5	说明 (续)	3	10	Application and Implementation	19
6	Pin Configuration and Functions	3	10.1	Application Information	19
7	Specifications	4	10.2	Typical Application	19
7.1	Absolute Maximum Ratings	4	11	Power Supply Recommendations	23
7.2	ESD Ratings	4	12	Layout	24
7.3	Recommended Operating Conditions	4	12.1	Layout Guidelines	24
7.4	Thermal Information	5	12.2	Layout Example	24
7.5	Electrical Characteristics	5	13	器件和文档支持	25
7.6	Timing Requirements	7	13.1	文档支持	25
7.7	Typical Characteristics	8	13.2	接收文档更新通知	25
8	Parameter Measurement Information	9	13.3	社区资源	25
9	Detailed Description	10	13.4	商标	25
9.1	Overview	10	13.5	静电放电警告	25
9.2	Functional Block Diagram	10	13.6	术语表	25
			14	机械、封装和可订购信息	25

4 修订历史记录

注：之前版本的页码可能与当前版本有所不同。

Changes from Revision A (May 2018) to Revision B	Page
• Changed the text in the <i>Default Device Configuration</i> section from: However the outputs are disabled by default and need to be turned on through I2C or with the S0 pin to: However the outputs are disabled by default and need to be turned on through I2C.	12
• Changed the <i>Factory Default Setting</i> table and <i>Default Configuration</i> graphic text to show that the Y1 outputs as 3-state when S0 = 1 or S0 = 0	13
• Changed the default value of the SLAVE_ADR 1:0 bits from: 00b to: 01b in the <i>Generic Configuration Register</i> table	16
• Changed the default value of the Y1_ST0 3:2 bits from: 11b to: 01b in the <i>Generic Configuration Register</i> table	16
• Changed the default value of the BCOUNT 7:1 bits from: 20h to: 00h in the <i>Generic Configuration Register</i> table	16
• Changed the default value of the Y2Y3_1 bit from: 1b to: 0b in the <i>PLL1 Configuration Register</i> table	17

Changes from Original (January 2017) to Revision A	Page
• Changed the <i>Factory Default Setting</i> table and <i>Default Configuration</i> graphic text to show that S0 = 1 means Y1 outputs 3-state and S0 = 0 means Y1 is enabled	13

5 说明 (续)

为了轻松实现器件自定义来满足应用需要，该器件支持使用非易失性 EEPROM 进行编程。所有器件设置均可通过 I2C 总线（一种两线制串行接口）进行编程。

CDCE813-Q1 在 1.8V 内核环境下运行，无需额外使用独立的 XTAL 振荡器，可减少组件数量并缩减电路板尺寸。它的运行温度范围为 -40°C 至 105°C 。

6 Pin Configuration and Functions

**PW Package
14-Pin TSSOP
Top View**

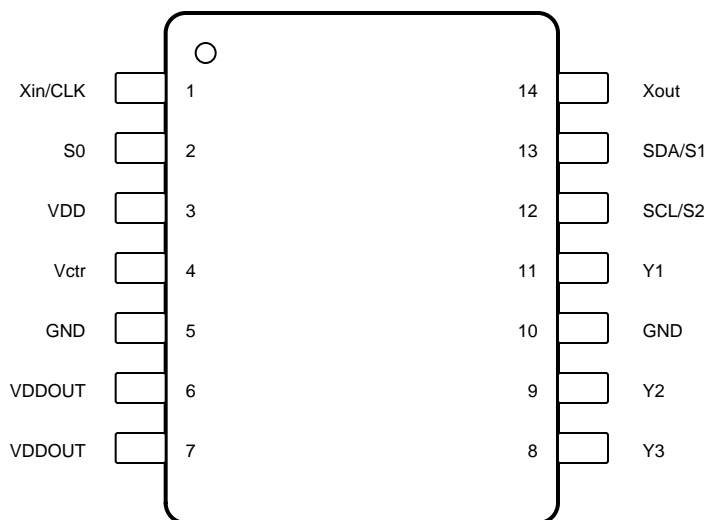

Pin Functions

PIN		TYPE ⁽¹⁾	DESCRIPTION
NAME	NO.		
GND	5, 10	G	Ground
SCL/S2	12	I	SCL: serial clock input LVCMOS (default configuration), 500-k Ω internal pullup; or S2: user-programmable control input, LVCMOS input, 500-k Ω internal pullup
SDA/S1	13	I/O or I	SDA: bidirectional serial data input or output (default configuration), LVCMOS internal pullup; or S1: user-programmable control input, LVCMOS input, 500-k Ω internal pullup
S0	2	I	User-programmable control input S0, LVCMOS input, 500-k Ω internal pullup
V _{ctr}	4	I	VCXO control voltage (leave open or pull up when not used)
V _{DD}	3	P	1.8-V power supply for the device
V _{DDOUT}	6, 7	P	CDCE813-Q1: 3.3-V or 2.5-V supply for all outputs
Xin/CLK	1	I	Crystal oscillator input or LVCMOS clock input (selectable through the I2C bus)
Xout	14	O	Crystal oscillator output (leave open or pull up when not used)
Y1	11	O	LVCMOS output
Y2	9	O	LVCMOS output
Y3	8	O	LVCMOS output

(1) G = Ground, I = Input, O = Output, P = Power

7 Specifications

7.1 Absolute Maximum Ratings

 over operating free-air temperature range (unless otherwise noted)⁽¹⁾

			MIN	MAX	UNIT
V _{DD}	Supply voltage		-0.5	2.5	V
V _{DDOUT}	Output clocks supply voltage	CDCE813-Q1	-0.5	3.6 + 0.5	V
V _I	Input voltage ⁽²⁾⁽³⁾		-0.5	V _{DD} + 0.5	V
V _O	Output voltage ⁽²⁾		-0.5	V _{DDOUT} + 0.5	V
I _I	Input current (V _I < 0, V _I > V _{DD})			20	mA
I _O	Continuous output current			50	mA
T _J	Maximum junction temperature			125	°C
T _{stg}	Storage temperature		-65	150	

- (1) Stresses beyond those listed under *Absolute Maximum Ratings* may cause permanent damage to the device. These are stress ratings only, and functional operation of the device at these or any other conditions beyond those indicated under *Recommended Operating Conditions* is not implied. Exposure to absolute-maximum-rated conditions for extended periods may affect device reliability.
- (2) The input and output negative voltage ratings may be exceeded if the input and output clamp-current ratings are observed.
- (3) SDA and SCL can go up to 3.6 V as stated in the *Recommended Operating Conditions* table.

7.2 ESD Ratings

			VALUE	UNIT
V _(ESD)	Electrostatic discharge	Human-body model (HBM), per AEC Q100-002 ⁽¹⁾	±2000	V
		Charged-device model (CDM), per AEC Q100-011	±1500	

- (1) AEC Q100-002 indicates that HBM stressing shall be in accordance with the ANSI/ESDA/JEDEC JS-001 specification.

7.3 Recommended Operating Conditions

			MIN	NOM	MAX	UNIT
V _{DD}	Device supply voltage		1.7	1.8	1.9	V
V _O	Output Yx supply voltage, V _{DDOUT}	CDCE813-Q1	2.3		3.6	V
V _{IL}	Low-level input voltage, LVCMOS				0.3 × V _{DD}	V
V _{IH}	High-level input voltage, LVCMOS		0.7 × V _{DD}			V
V _{I(thresh)}	Input voltage threshold, LVCMOS			0.5 × V _{DD}		V
V _{I(S)}	Input voltage range, S0		0		1.9	V
	Input voltage range S1, S2, SDA, SCL (V _{I(thresh)} = 0.5 V _{DD})		0		3.6	
V _{I(CLK)}	Input voltage range CLK		0		1.9	V
I _{OH} , I _{OL}	Output current	V _{DDOUT} = 3.3 V			±12	mA
		V _{DDOUT} = 2.5 V			±10	
C _L	Output load, LVCMOS				15	pF
T _A	Operating ambient temperature		-40		105	°C

Recommended Operating Conditions (continued)

		MIN	NOM	MAX	UNIT
CRYSTAL AND VCXO SPECIFICATIONS⁽¹⁾					
f _{Xtal}	Crystal input frequency range (fundamental mode)	8	27	32	MHz
ESR	Effective series resistance			100	Ω
f _{PR}	Pulling range (0 V ≤ V _{ctr} ≤ 1.8 V) ⁽²⁾	±120	±150		ppm
V _{ctr}	Frequency control voltage	0		V _{DD}	V
C ₀ / C ₁	Pullability ratio			220	
C _L	On-chip load capacitance at Xin and Xout	0		20	pF

- (1) For more information about VCXO configuration, and crystal recommendation, see application report [VCXO Application Guideline for CDCE\(L\)9xx Family](#) (SCAA085).
- (2) Pulling range depends on crystal type, on-chip crystal load capacitance, and PCB stray capacitance; pulling range of minimum ±120 ppm applies for crystal listed in the application report [VCXO Application Guideline for CDCE\(L\)9xx Family](#) (SCAA085).

7.4 Thermal Information

THERMAL METRIC ⁽¹⁾⁽²⁾		CDCE813-Q1	UNIT
		PW (TSSOP)	
		14 PINS	
R _{θJA}	Junction-to-ambient thermal resistance	110.6	°C/W
R _{θJC(top)}	Junction-to-case (top) thermal resistance	35.4	°C/W
R _{θJB}	Junction-to-board thermal resistance	53.6	°C/W
ψ _{JT}	Junction-to-top characterization parameter	2.1	°C/W
ψ _{JB}	Junction-to-board characterization parameter	52.8	°C/W
R _{θJC(bot)}	Junction-to-case (bottom) thermal resistance	—	°C/W

- (1) For more information about traditional and new thermal metrics, see the [Semiconductor and IC Package Thermal Metrics](#) application report.
- (2) The package thermal impedance is calculated in accordance with JESD 51 and JEDEC2S2P (high-K board).

7.5 Electrical Characteristics

over recommended operating free-air temperature range (unless otherwise noted)

		TEST CONDITIONS		MIN	TYP ⁽¹⁾	MAX	UNIT
OVERALL PARAMETER							
I _{DD}	Supply current (see Figure 1)	All outputs off, f _{CLK} = 27 MHz, f _{VCO} = 135 MHz, f _{OUT} = 27 MHz	All PLLS on	11			mA
			Per PLL	9			
I _{DD(OUT)}	Supply current (see Figure 2)	No load, all outputs on, f _{OUT} = 27 MHz	V _{DDOUT} = 3.3 V	1.3			mA
I _{DD(PD)}	Power-down current. Every circuit powered down except I2C	f _{IN} = 0 MHz, V _{DD} = 1.9 V		30			μA
V _(PUC)	Supply voltage V _{DD} threshold for power-up control circuit			0.85		1.45	V
f _{VCO}	VCO frequency range of PLL			70		230	MHz
f _{OUT}	LVCOS output frequency	V _{DDOUT} = 3.3 V				230	MHz

- (1) All typical values are at respective nominal V_{DD}.

Electrical Characteristics (continued)

over recommended operating free-air temperature range (unless otherwise noted)

		TEST CONDITIONS	MIN	TYP ⁽¹⁾	MAX	UNIT
LVC MOS PARAMETER						
V _{IK}	LVC MOS input voltage	V _{DD} = 1.7 V, I _I = -18 mA			-1.2	V
I _I	LVC MOS input current	V _I = 0 V or V _{DD} , V _{DD} = 1.9 V			±5	μA
I _{IH}	LVC MOS input current for S0, S1, and S2	V _I = V _{DD} , V _{DD} = 1.9 V			5	μA
I _{IL}	LVC MOS input current for S0, S1, and S2	V _I = 0 V, V _{DD} = 1.9 V			-4	μA
C _I	Input capacitance at Xin/CLK	V _{ICLK} = 0 V or V _{DD}		6		pF
	Input capacitance at Xout	V _{Ixout} = 0 V or V _{DD}		2		
	Input capacitance at S0, S1, and S2	V _{IS} = 0 V or V _{DD}		3		
CDCE813-Q1, LVC MOS PARAMETER FOR V_{DDOUT} = 3.3-V MODE						
V _{OH}	LVC MOS high-level output voltage	V _{DDOUT} = 3 V, I _{OH} = -0.1 mA	2.9			V
		V _{DDOUT} = 3 V, I _{OH} = -8 mA	2.4			
		V _{DDOUT} = 3 V, I _{OH} = -12 mA	2.2			
V _{OL}	LVC MOS low-level output voltage	V _{DDOUT} = 3 V, I _{OL} = 0.1 mA		0.1		V
		V _{DDOUT} = 3 V, I _{OL} = 8 mA		0.5		
		V _{DDOUT} = 3 V, I _{OL} = 12 mA		0.8		
t _{PLH} , t _{PHL}	Propagation delay	PLL bypass		3.2		ns
		PLL enabled (f _{CLK} = f _{VCO}), 70 MHz ≤ f _{VCO} ≤ 85 MHz	1.6		4.3	
t _r , t _f	Rise and fall time	V _{DDOUT} = 3.3 V (20%–80%)		0.6		ns
t _{jit(cc)}	Cycle-to-cycle jitter ⁽²⁾	1 PLL switching, Y2-to-Y3, 10,000 cycles		50	200	ps
t _{jit(per)}	Peak-to-peak period jitter ⁽²⁾	1 PLL switching, Y2-to-Y3		60	200	ps
t _{sk(o)}	Output skew (see Table 2) ⁽³⁾	f _{OUT} = 50 MHz, Y1-to-Y3			440	ps
odc	Output duty cycle ⁽⁴⁾	f _{VCO} = 100 MHz, Pdiv = 1	45%		55%	
CDCE813-Q1, LVC MOS PARAMETER FOR V_{DDOUT} = 2.5-V MODE						
V _{OH}	LVC MOS high-level output voltage	V _{DDOUT} = 2.3 V, I _{OH} = -0.1 mA	2.2			V
		V _{DDOUT} = 2.3 V, I _{OH} = -6 mA	1.7			
		V _{DDOUT} = 2.3 V, I _{OH} = -10 mA	1.6			
V _{OL}	LVC MOS low-level output voltage	V _{DDOUT} = 2.3 V, I _{OL} = 0.1 mA		0.1		V
		V _{DDOUT} = 2.3 V, I _{OL} = 6 mA		0.5		
		V _{DDOUT} = 2.3 V, I _{OL} = 10 mA		0.7		
t _{PLH} , t _{PHL}	Propagation delay	PLL bypass		3.6		ns
t _r , t _f	Rise and fall time	V _{DDOUT} = 2.5 V (20%–80%)		0.8		ns
t _{jit(cc)}	Cycle-to-cycle jitter ⁽²⁾	1 PLL switching, Y2-to-Y3, 10,000 cycles		50	200	ps
t _{jit(per)}	Peak-to-peak period jitter ⁽²⁾	1 PLL switching, Y2-to-Y3		60	200	ps
t _{sk(o)}	Output skew (see Table 2) ⁽³⁾	f _{OUT} = 50 MHz, Y1-to-Y3			440	ps
odc	Output duty cycle ⁽⁴⁾	f _{VCO} = 100 MHz, Pdiv = 1	45%		55%	

 (2) Jitter depends on configuration. Jitter data is for input frequency = 27 MHz, f_{VCO} = 108 MHz, f_{OUT} = 27 MHz (measured at Y2).

 (3) The t_{sk(o)} specification is only valid for equal loading of each bank of outputs, and the outputs are generated from the same divider.

 (4) odc depends on the output rise and fall time (t_r and t_f); data sampled on the rising edge (t_r)

Electrical Characteristics (continued)

over recommended operating free-air temperature range (unless otherwise noted)

		TEST CONDITIONS	MIN	TYP ⁽¹⁾	MAX	UNIT
I2C PARAMETER						
V _{IK}	SCL and SDA input clamp voltage	V _{DD} = 1.7 V, I _I = –18 mA			–1.2	V
I _{IH}	SCL and SDA input current	V _I = V _{DD} , V _{DD} = 1.9 V			±10	μA
V _{IH}	I2C input high voltage ⁽⁵⁾		0.7 × V _{DD}			V
V _{IL}	I2C input low voltage ⁽⁵⁾				0.3 × V _{DD}	V
V _{OL}	SDA low-level output voltage	I _{OL} = 3 mA, V _{DD} = 1.7 V			0.2 × V _{DD}	V
C _I	SCL-SDA input capacitance	V _I = 0 V or V _{DD}		3	10	pF
EEPROM SPECIFICATION						
EE _{cy}	Programming cycles of EEPROM		100	1000		cycles
EE _{ret}	Data retention		10			years

(5) SDA and SCL pins are 3.3-V tolerant.

7.6 Timing Requirements

over recommended ranges of supply voltage, load, and operating free-air temperature

		MIN	NOM	MAX	UNIT
CLK_IN					
f _{CLK}	LVCMOS clock input frequency	PLL bypass mode	0	160	MHz
		PLL mode	8	160	
t _r and t _f	Rise and fall time, CLK signal (20% to 80%)			3	ns
	Duty cycle of CLK at V _{DD} / 2	40%		60%	
I2C (SEE Figure 12)					
f _{SCL}	SCL clock frequency	Standard mode	0	100	kHz
		Fast mode	0	400	
t _{SU(START)}	START setup time (SCL high before SDA low)	Standard mode	4.7		μs
		Fast mode	0.6		
t _{H(START)}	START hold time (SCL low after SDA low)	Standard mode	4		μs
		Fast mode	0.6		
t _{W(SCLL)}	SCL low-pulse duration	Standard mode	4.7		μs
		Fast mode	1.3		
t _{W(SCLH)}	SCL high-pulse duration	Standard mode	4		μs
		Fast mode	0.6		
t _{H(SDA)}	SDA hold time (SDA valid after SCL low)	Standard mode	0	3.45	μs
		Fast mode	0	0.9	
t _{SU(SDA)}	SDA setup time	Standard mode	250		ns
		Fast mode	100		
t _r	SCL-SDA input rise time	Standard mode		1000	ns
		Fast mode		300	
t _f	SCL-SDA input fall time			300	ns
t _{SU(STOP)}	STOP setup time	Standard mode	4		μs
		Fast mode	0.6		
t _{BUS}	Bus free time between a STOP and START condition	Standard mode	4.7		μs
		Fast mode	1.3		

CDCE813-Q1

ZHCSG21B – JANUARY 2017 – REVISED MAY 2018

www.ti.com.cn

7.7 Typical Characteristics

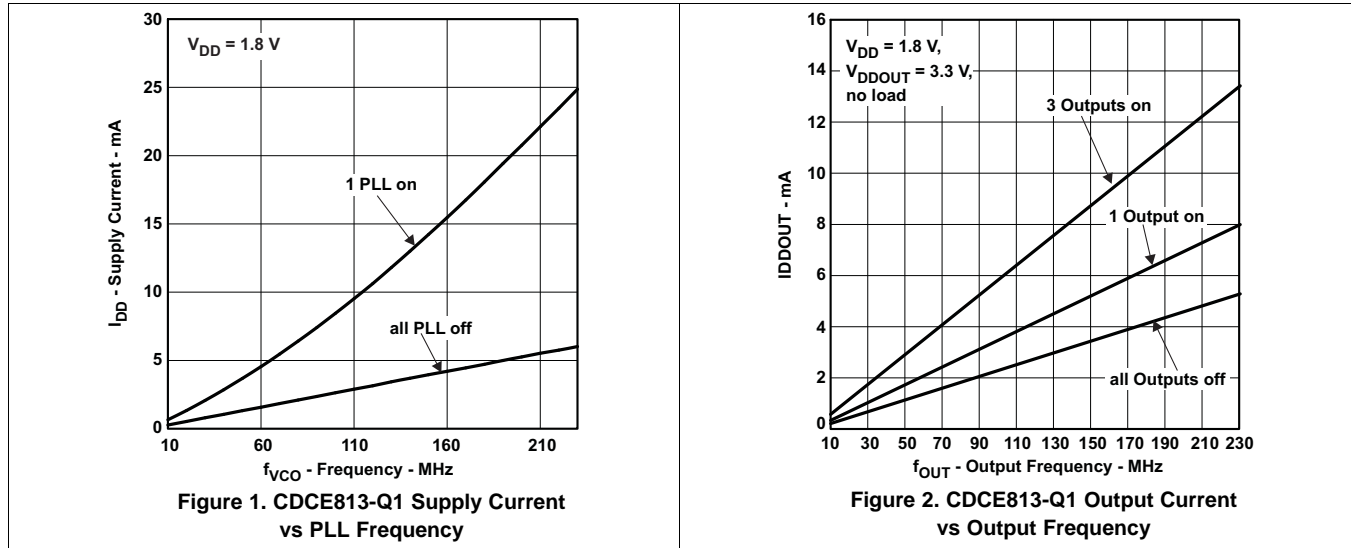

8 Parameter Measurement Information

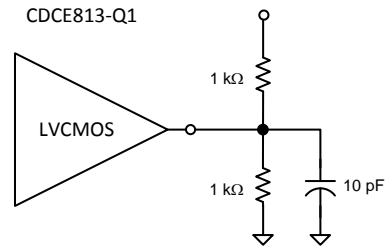

Copyright © 2017, Texas Instruments Incorporated

Figure 3. Test Load

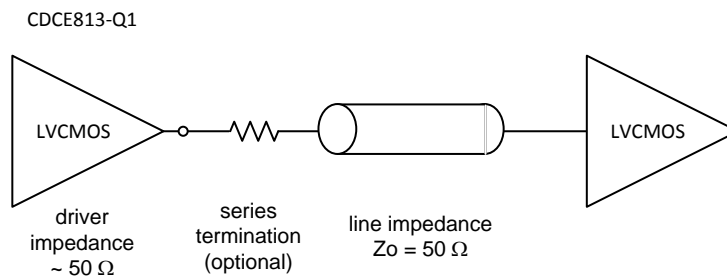

Copyright © 2017, Texas Instruments Incorporated

Figure 4. Test Load for 50- Ω Board Environment

9 Detailed Description

9.1 Overview

The CDCExxx-Q1 devices are modular PLL-based, low-cost, high-performance, programmable clock synthesizers, multipliers, and dividers. They generate up to three output clocks from a single input frequency. Each output can be programmed in-system for any clock frequency up to 230 MHz, using the integrated configurable PLL.

The CDCE813-Q1 device has separate output supply pins, V_{DDOUT} , with output of 2.5 V to 3.3 V.

The input accepts an external crystal or LVCMOS clock signal. If an external crystal is used, an on-chip load capacitor is adequate for most applications. The value of the load capacitor is programmable from 0 pF to 20 pF. Additionally, a selectable on-chip VCXO allows synchronization of the output frequency to an external control signal, that is, the PWM signal.

The deep M / N divider ratio allows the generation of zero-ppm audio-video, networking (WLAN, Bluetooth, Ethernet, GPS) or interface (USB, IEEE1394, memory stick) clocks from, for example, a 27-MHz reference input frequency.

The PLL supports spread-spectrum clocking (SSC). SSC can be center-spread or down-spread clocking, which is a common technique to reduce electromagnetic interference (EMI).

Based on the PLL frequency and the divider settings, the internal loop filter components are automatically adjusted to achieve high stability and optimized jitter transfer characteristics.

The device supports nonvolatile EEPROM programming for easy customization of the device to the application. It is preset to a factory default configuration (see [Default Device Configuration](#)). It can be reprogrammed to a different application configuration before PCB assembly, or reprogrammed by in-system programming. All device settings are programmable through the SDA-SCL bus, a 2-wire serial interface.

Three programmable control inputs, S0, S1, and S2, can be used to select different frequencies, change SSC setting for lowering EMI, or control other features like outputs disable to low, outputs in Hi-Z state, power down, PLL bypass, and so forth).

The CDCE813-Q1 core operates in a 1.8-V environment. It operates in a temperature range of -40°C to 105°C .

9.2 Functional Block Diagram

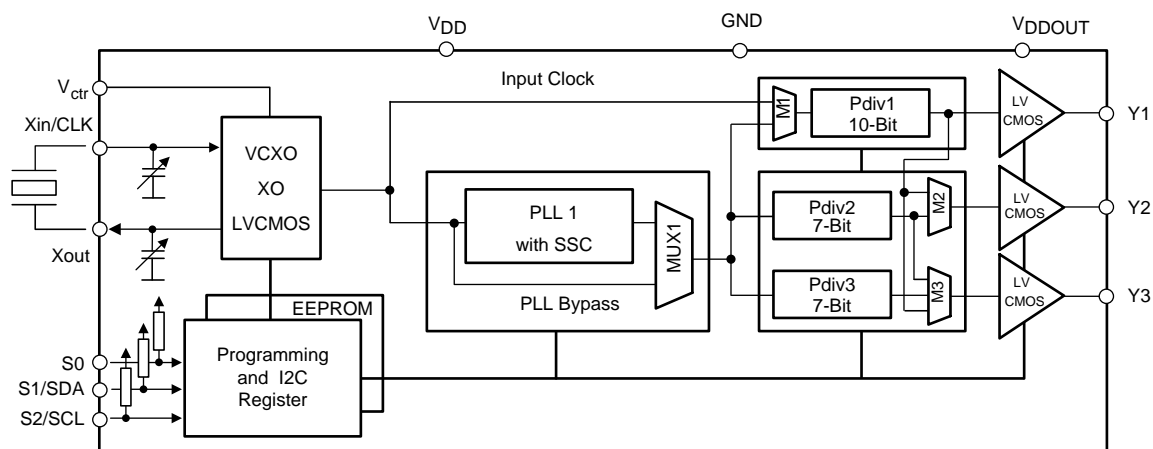

Copyright © 2017, Texas Instruments Incorporated

9.3 Feature Description

9.3.1 Control Terminal Configuration

The CDCE813-Q1 device has three user-definable control terminals (S0, S1, and S2), which allow external control of device settings. They can be programmed to any of the following functions:

- Spread-spectrum clocking selection → spread type and spread amount selection
- Frequency selection → switching between any of two user-defined frequencies
- Output state selection → output configuration and power-down control

The user can predefine up to eight different control settings. Table 1 and Table 2 explain these settings.

Table 1. Control Terminal Definition

EXTERNAL CONTROL BITS	PLL1 SETTING			Y1 SETTING
Control function	PLL frequency selection	SSC selection	Output Y2 and Y3 selection	Output Y1 and power-down selection

Table 2. PLL1 Setting ⁽¹⁾

SSCx [3 BITS]			CENTER	DOWN
SSC SELECTION (CENTER AND DOWN)				
0	0	0	0% (off)	0% (off)
0	0	1	±0.25%	–0.25%
0	1	0	±0.5%	–0.5%
0	1	1	±0.75%	–0.75%
1	0	0	±1.0%	–1.0%
1	0	1	±1.25%	–1.25%
1	1	0	±1.5%	–1.5%
1	1	1	±2.0%	–2.0%

(1) Center and down-spread, Frequency0, Frequency1, State0, and State1 are user-definable in PLL1 configuration register.

Table 3. PLL1 Setting, Frequency Selection ⁽¹⁾

FSx	FUNCTION
0	Frequency 0
1	Frequency 1

(1) Frequency0 and Frequency1 can be any frequency within the specified f_{VCO} range.

Table 4. PLL1 Setting, Output Selection (Y2, Y3) ⁽¹⁾

Y2, Y3	FUNCTION
0	State 0
1	State 1

(1) State0 or State1 selection is valid for both outputs of the corresponding PLL module and can be power down, Hi-Z state, low, or active.

Table 5. Y1 Setting ⁽¹⁾

Y1	FUNCTION
0	State 0
1	State 1

(1) State0 and State1 are user definable in the generic configuration register and can be power down, Hi-Z state, low, or active.

The S1/SDA and S2/SCL pins of the CDCE813-Q1 device are dual-function pins. In the default configuration, they are defined as SDA and SCL for the serial programming interface. They can be programmed as control pins (S1 and S2) by setting the appropriate bits in the EEPROM.

NOTE

Changes to the control register (Bit [6] of byte 02h) have no effect until they are written into the EEPROM.

Once they are set as control pins, the serial programming interface is no longer available. However, if V_{DDOUT} is forced to GND, the two control pins, S1 and S2, temporally act as serial programming pins (SDA and SCL).

S0 is *not* a multi-use pin; it is a control pin only.

9.3.2 Default Device Configuration

The internal EEPROM of the CDCE813-Q1 device is pre-configured with a factory default configuration as shown in Figure 5 (the input frequency is routed through PLL1 to the outputs as a default). This mode can be used to clean the jitter of an incoming clock signal. However the outputs are disabled by default and need to be turned on through I2C.

The default setting appears either after power is supplied or after a power-down – power-up sequence until it is reprogrammed by the user to a different application configuration. A new register setting is programmed through the serial I2C interface.

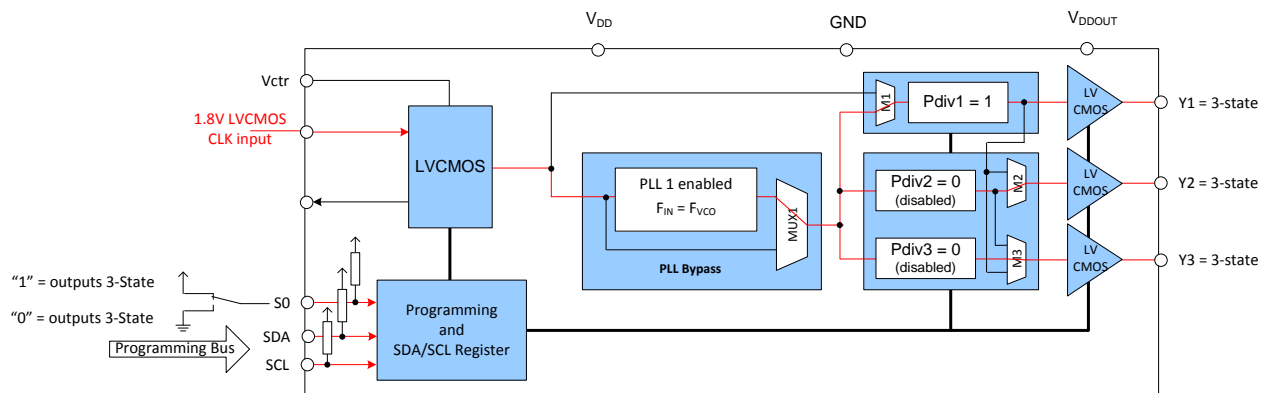

Figure 5. Default Configuration

Table 6 shows the factory default setting for the Control Terminal Register.

NOTE

Even though eight different register settings are possible, in the default configuration, only the first two settings (0 and 1) can be selected with S0, as S1 and S2 are configured as programming pins in default mode.

Table 6. Factory Default Setting for Control Terminal Register ⁽¹⁾

EXTERNAL CONTROL PINS			Y1	PLL1 SETTINGS		
			OUTPUT SELECTION	FREQUENCY SELECTION	SSC SELECTION	OUTPUT SELECTION
S2	S1	S0	Y1	FS1	SSC1	Y2Y3
SCL (I ² C)	SDA (I ² C)	0	3-state	f _{VCO1_0}	Off	3-state
SCL (I ² C)	SDA (I ² C)	1	3-state	f _{VCO1_0}	Off	3-state

(1) In default mode or when programmed respectively, S1 and S2 act as serial programming interface, I²C. They do not have any control-pin function but they are internally interpreted as if S1 = 0 and S2 = 0. S0, however, is a control pin, which in the default mode switches all outputs ON or OFF (as previously predefined).

9.3.3 I²C Serial Interface

The CDCE813-Q1 device operates as a slave device on the 2-wire serial I²C bus compatible with the popular SMBus or I²C specification. It operates in the standard-mode transfer (up to 100 kbps) and fast-mode transfer (up to 400 kbps) and supports 7-bit addressing.

The S1/SDA and S2/SCL pins of the CDCE813-Q1 device are dual-function pins. In the default configuration, they are used as the I²C serial programming interface. They can be reprogrammed as general-purpose control pins, S1 and S2, by changing the corresponding EEPROM setting, byte 02h, bit [6].

9.3.4 Data Protocol

The device supports *Byte Write and Byte Read* and *Block Write and Block Read* operations.

For *Byte Write/Read* operations, the system controller can individually access addressed bytes.

For *Block Write/Read* operations, the bytes are accessed in sequential order from lowest to highest byte (with most-significant bit first) with the ability to stop after any complete byte has been transferred. The numbers of bytes read out are defined by Byte Count in the generic configuration register. At the *Block Read* instruction, all bytes defined in Byte Count must be read out to finish the read cycle correctly.

Once a byte has been sent, it is written into the internal register and is effective immediately. This applies to each transferred byte, regardless of whether this is a *Byte Write* or a *Block Write* sequence.

If the EEPROM write cycle is initiated, the internal SDA registers are written into the EEPROM. During this write cycle, data is not accepted at the I²C bus until the write cycle is completed. However, data can be read out during the programming sequence (*Byte Read* or *Block Read*). The programming status can be monitored by *EEPIP*, byte 01h–bit 6.

The offset of the indexed byte is encoded in the command code, as described in [Table 7](#).

Table 7. Slave Receiver Address (7 Bits)

DEVICE	A6	A5	A4	A3	A2	A1 ⁽¹⁾	A0 ⁽¹⁾	R/W
CDCE813-Q1	1	1	0	0	1	0	1	1/0
CDCEx925	1	1	0	0	1	0	0	1/0
CDCEx937	1	1	0	1	1	0	1	1/0
CDCEx949	1	1	0	1	1	0	0	1/0

(1) Address bits A0 and A1 are programmable through the I²C bus (byte 01, bits [1:0]). This allows addressing up to 4 devices connected to the same I²C bus. The least-significant bit of the address byte designates a write or read operation.

9.4 Device Functional Modes

9.4.1 SDA and SCL Hardware Interface

[Figure 6](#) shows how the CDCE813-Q1 clock synthesizer is connected to the I²C serial interface bus. Multiple devices can be connected to the bus, but it may be necessary to reduce the speed (400 kHz is the maximum) if many devices are connected.

Device Functional Modes (continued)

Note that the pullup resistors (R_p) depend on the supply voltage, bus capacitance, and number of connected devices. The recommended pullup value is 4.7 k Ω . The resistor must meet the minimum sink current of 3 mA at $V_{OLmax} = 0.4$ V for the output stages (for more details see the SMBus or I²C Bus specifications in the [Timing Requirements](#) table).

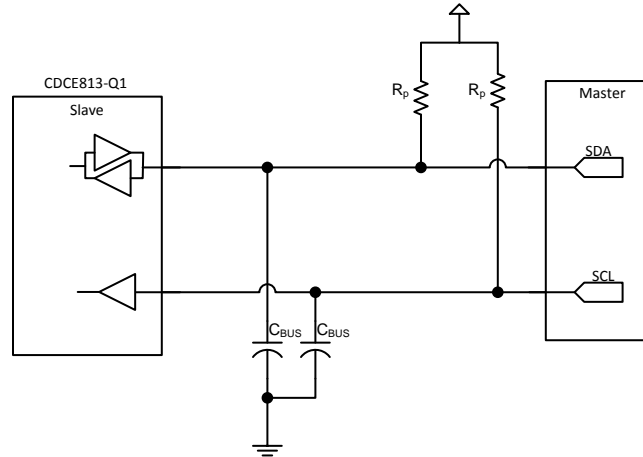

Copyright © 2017, Texas Instruments Incorporated

Figure 6. I2C Hardware Interface

9.5 Programming

Table 8. Command Code Definition

BIT	DESCRIPTION
7	0 = Block Read or Block Write operation 1 = Byte Read or Byte Write operation
(6:0)	Byte offset for Byte Read, Block Read, Byte Write, and Block Write operations

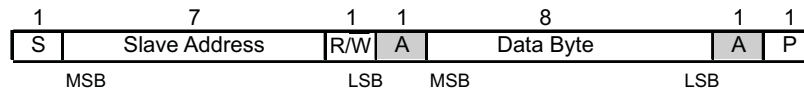

- S** Start Condition
- Sr** Repeated Start Condition
- R/W** 1 = Read (Rd) From CDCE9xx Device; 0 = Write (Wr) to CDCE9xxx
- A** Acknowledge (ACK = 0 and NACK =1)
- P** Stop Condition
- Master-to-Slave Transmission
- Slave-to-Master Transmission

Figure 7. Generic Programming Sequence

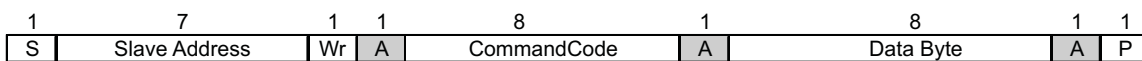

Figure 8. Byte Write Protocol

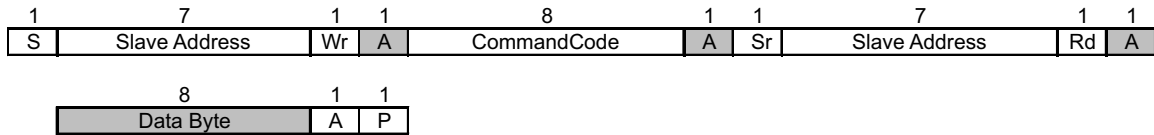
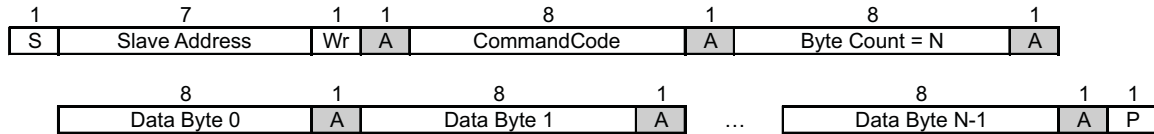

Figure 9. Byte Read Protocol



- (1) Data byte 0 bits [7:0] is reserved for Revision Code and Vendor Identification. Also, it is used for internal test purpose and should not be overwritten.

Figure 10. Block Write Protocol

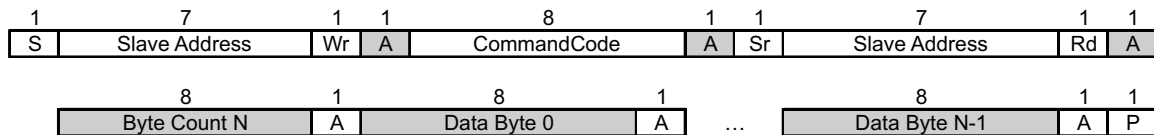

Figure 11. Block Read Protocol

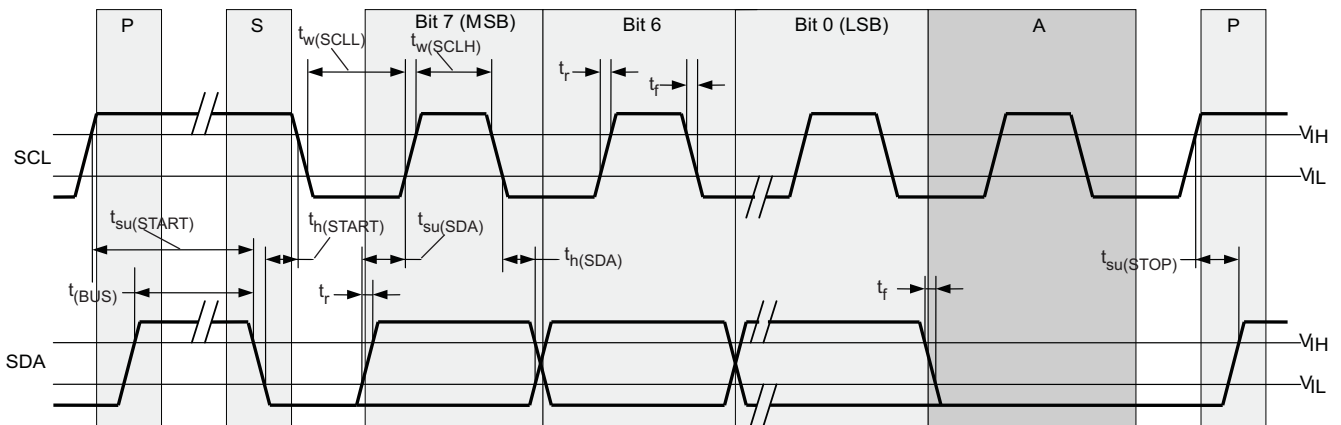

Figure 12. Timing Diagram for I2C Serial Control Interface

9.6 Register Maps

9.6.1 I2C Configuration Registers

The clock input, control pins, PLLs, and output stages are user configurable. The following tables and explanations describe the programmable functions of the CDCE813-Q1 device. All settings can be manually written into the device through the I2C bus or easily programmed by using the TI Pro-Clock™ software. TI Pro-Clock™ software allows the user to make all settings quickly, and automatically calculates the values for optimized performance at lowest jitter.

Table 9. I2C Registers

ADDRESS OFFSET	REGISTER DESCRIPTION	TABLE
00h	Generic configuration register	Table 11
10h	PLL1 configuration register	Table 12

Table 11. Generic Configuration Register (continued)

OFFSET ⁽¹⁾	BIT ⁽²⁾	ACRONYM	DEFAULT ⁽³⁾	DESCRIPTION
04h	7	Y1_7	0b	Y1_x State selection ⁽⁷⁾ 0 – State0 (predefined by Y1_ST0) 1 – State1 (predefined by Y1_ST1)
	6	Y1_6	0b	
	5	Y1_5	0b	
	4	Y1_4	0b	
	3	Y1_3	0b	
	2	Y1_2	0b	
	1	Y1_1	0b	
	0	Y1_0	0b	
05h	7:3	XCSEL	00h	Crystal load capacitor selection ⁽⁸⁾ 00h – 0 pF 01h – 1 pF 02h – 2 pF :14h to 1Fh – 20 pF
	2:0		0b	Reserved – do not write other than 0
06h	7:1	BCOUNT	00h	7-bit byte count (defines the number of bytes which will be sent from this device at the next <i>Block Read</i> transfer); all bytes must be read out to finish the read cycle correctly.
	0	EEWRITE	0b	Initiate EEPROM write cycle ⁽⁴⁾⁽⁹⁾ 0 – No EEPROM write cycle 1 – Start EEPROM write cycle (internal registers are saved to the EEPROM)
07h-0Fh		—	0h	Unused address range

- (7) These are the bits of the control terminal register (see [Table 10](#)). The user can predefine up to eight different control settings. These settings then can be selected by the external control pins, S0, S1, and S2.
- (8) The internal load capacitor (C1, C2) must be used to achieve the best clock performance. External capacitors should be used only to finely adjust C_L by a few picofarads. The value of C_L can be programmed with a resolution of 1 pF for a crystal load range of 0 pF to 20 pF. For C_L > 20 pF, use additional external capacitors. The device input capacitance value must be considered, which always adds 1.5 pF (6 pF/2 pF) to the selected C_L. For more about VCXO configuring and crystal recommendation, see application report [VCXO Application Guideline for CDCE\(L\)9xx Family](#) (SCAA085).
- (9) The EEPROM WRITE bit must be sent last. This ensures that the content of all internal registers are stored in the EEPROM. The EEWRITE cycle is initiated with the rising edge of the EEWRITE bit. A static level-high does not trigger an EEPROM WRITE cycle. The EEWRITE bit must be reset to low after the programming is completed. The programming status can be monitored by reading out EEPIP. If EELOCK is set to high, no EEPROM programming is possible.

Table 12. PLL1 Configuration Register

OFFSET ⁽¹⁾	BIT ⁽²⁾	ACRONYM	DEFAULT ⁽³⁾	DESCRIPTION																		
10h	7:5	SSC1_7 [2:0]	000b	SSC1: PLL1 SSC selection (modulation amount). ⁽⁴⁾ <table border="0"> <tr> <td>Down</td> <td>Center</td> </tr> <tr> <td>000 (off)</td> <td>000 (off)</td> </tr> <tr> <td>001 – 0.25%</td> <td>001 ± 0.25%</td> </tr> <tr> <td>010 – 0.5%</td> <td>010 ± 0.5%</td> </tr> <tr> <td>011 – 0.75%</td> <td>011 ± 0.75%</td> </tr> <tr> <td>100 – 1.0%</td> <td>100 ± 1.0%</td> </tr> <tr> <td>101 – 1.25%</td> <td>101 ± 1.25%</td> </tr> <tr> <td>110 – 1.5%</td> <td>110 ± 1.5%</td> </tr> <tr> <td>111 – 2.0%</td> <td>111 ± 2.0%</td> </tr> </table>	Down	Center	000 (off)	000 (off)	001 – 0.25%	001 ± 0.25%	010 – 0.5%	010 ± 0.5%	011 – 0.75%	011 ± 0.75%	100 – 1.0%	100 ± 1.0%	101 – 1.25%	101 ± 1.25%	110 – 1.5%	110 ± 1.5%	111 – 2.0%	111 ± 2.0%
	Down	Center																				
	000 (off)	000 (off)																				
001 – 0.25%	001 ± 0.25%																					
010 – 0.5%	010 ± 0.5%																					
011 – 0.75%	011 ± 0.75%																					
100 – 1.0%	100 ± 1.0%																					
101 – 1.25%	101 ± 1.25%																					
110 – 1.5%	110 ± 1.5%																					
111 – 2.0%	111 ± 2.0%																					
4:2	SSC1_6 [2:0]	000b																				
1:0	SSC1_5 [2:1]	000b																				
7	SSC1_5 [0]																					
11h	6:4	SSC1_4 [2:0]	000b																			
	3:1	SSC1_3 [2:0]	000b																			
	0	SSC1_2 [2]	000b																			
12h	7:6	SSC1_2 [1:0]	000b																			
	5:3	SSC1_1 [2:0]																				
	2:0	SSC1_0 [2:0]																				
13h	7	FS1_7	0b	FS1_x: PLL1 frequency selection ⁽⁴⁾ 0 – f _{VCO1_0} (predefined by PLL1_0 – multiplier/divider value) 1 – f _{VCO1_1} (predefined by PLL1_1 – multiplier/divider value)																		
	6	FS1_6	0b																			
	5	FS1_5	0b																			
	4	FS1_4	0b																			
	3	FS1_3	0b																			
	2	FS1_2	0b																			
	1	FS1_1	0b																			
	0	FS1_0	0b																			

- (1) Writing data beyond 20h may adversely affect device function.
- (2) All data is transferred MSB-first.
- (3) Unless a custom setting is used
- (4) The user can predefine up to eight different control settings. In normal device operation, these settings can be selected by the external control pins, S0, S1, and S2.

Table 12. PLL1 Configuration Register (continued)

OFFSET ⁽¹⁾	BIT ⁽²⁾	ACRONYM	DEFAULT ⁽³⁾	DESCRIPTION		
14h	7	MUX1	0b	PLL1 multiplexer:	0 – PLL1 1 – PLL1 bypass (PLL1 is in power down)	
	6	M2	1b	Output Y2 multiplexer:	0 – Pdiv1 1 – Pdiv2	
	5:4	M3	10b	Output Y3 Multiplexer:	00 – Pdiv1-divider 01 – Pdiv2-divider 10 – Pdiv3-divider 11 – Reserved	
	3:2	Y2Y3_ST1	00b	Y2, Y3- State0/1 definition:	00 – Y2 and Y3 disabled to Hi-Z state (PLL1 is in power down) 01 – Y2 and Y3 disabled to Hi-Z state	
	1:0	Y2Y3_ST0	01b		10 – Y2 and Y3 disabled to low 11 – Y2 and Y3 enabled	
15h	7	Y2Y3_7	0b	Y2Y3_x output state selection. ⁽⁴⁾ 0 – State0 (predefined by Y2Y3_ST0) 1 – State1 (predefined by Y2Y3_ST1)		
	6	Y2Y3_6	0b			
	5	Y2Y3_5	0b			
	4	Y2Y3_4	0b			
	3	Y2Y3_3	0b			
	2	Y2Y3_2	0b			
	1	Y2Y3_1	0b			
	0	Y2Y3_0	0b			
16h	7	SSC1DC	0b	PLL1 SSC down or center selection:	0 – Down 1 – Center	
	6:0	Pdiv2	00h	7-bit Y2-output-divider Pdiv2:	0 – Reset and standby 1 to 127 – Divider value	
17h	7	—	0b	Reserved – do not write other than 0		
	6:0	Pdiv3	00h	7-bit Y3-output-divider Pdiv3:	0 – Reset and standby 1 to 127 – Divider value	
18h	7:0	PLL1_0N [11:4]	1FFh	PLL1_0 ⁽⁵⁾ : 30-bit multiplier or divider value for frequency f_{VCO1_0} (for more information, see PLL Frequency Planning).		
19h	7:4	PLL1_0N [3:0]				
	3:0	PLL1_0R [8:5]	000h			
1Ah	7:3	PLL1_0R[4:0]				
	2:0	PLL1_0Q [5:3]	10h			
1Bh	7:5	PLL1_0Q [2:0]				
	4:2	PLL1_0P [2:0]	100b			VCO1_0 range selection:
1Ch	7:0	PLL1_1N [11:4]	1FFh			
1Dh	7:4	PLL1_1N [3:0]				
	3:0	PLL1_1R [8:5]	000h			
1Eh	7:3	PLL1_1R[4:0]				
	2:0	PLL1_1Q [5:3]	10h			
1Fh	7:5	PLL1_1Q [2:0]				
	4:2	PLL1_1P [2:0]	100b	VCO1_1 range selection:	00 – $f_{VCO1_1} < 125$ MHz 01 – $125 \text{ MHz} \leq f_{VCO1_1} < 150$ MHz 10 – $150 \text{ MHz} \leq f_{VCO1_1} < 175$ MHz 11 – $f_{VCO1_1} \geq 175$ MHz	
	1:0	VCO1_1_RANGE	00b			

(5) PLL settings limits: $16 \leq q \leq 63$, $0 \leq p \leq 7$, $0 \leq r \leq 511$, $0 < N < 4096$

10 Application and Implementation

NOTE

Information in the following applications sections is not part of the TI component specification, and TI does not warrant its accuracy or completeness. TI's customers are responsible for determining suitability of components for their purposes. Customers should validate and test their design implementation to confirm system functionality.

10.1 Application Information

The CDCE813-Q1 device is an easy-to-use, high-performance, programmable CMOS clock synthesizer which can be used as a crystal buffer, clock synthesizer with separate output supply pin. The CDCE813-Q1 device features an on-chip loop filter and spread-spectrum modulation. Programming can be done through the I2C interface, or previously saved settings can be loaded from on-chip EEPROM. The pins S0, S1, and S2 can be programmed as control pins to select various output settings. This section shows some examples of using the CDCE813-Q1 device in various applications.

10.2 Typical Application

Figure 13 shows the application example of CDCE813-Q1 in combination with an SoC processor and an FPD-Link3 serializer, serving as a PCLK jitter cleaner.

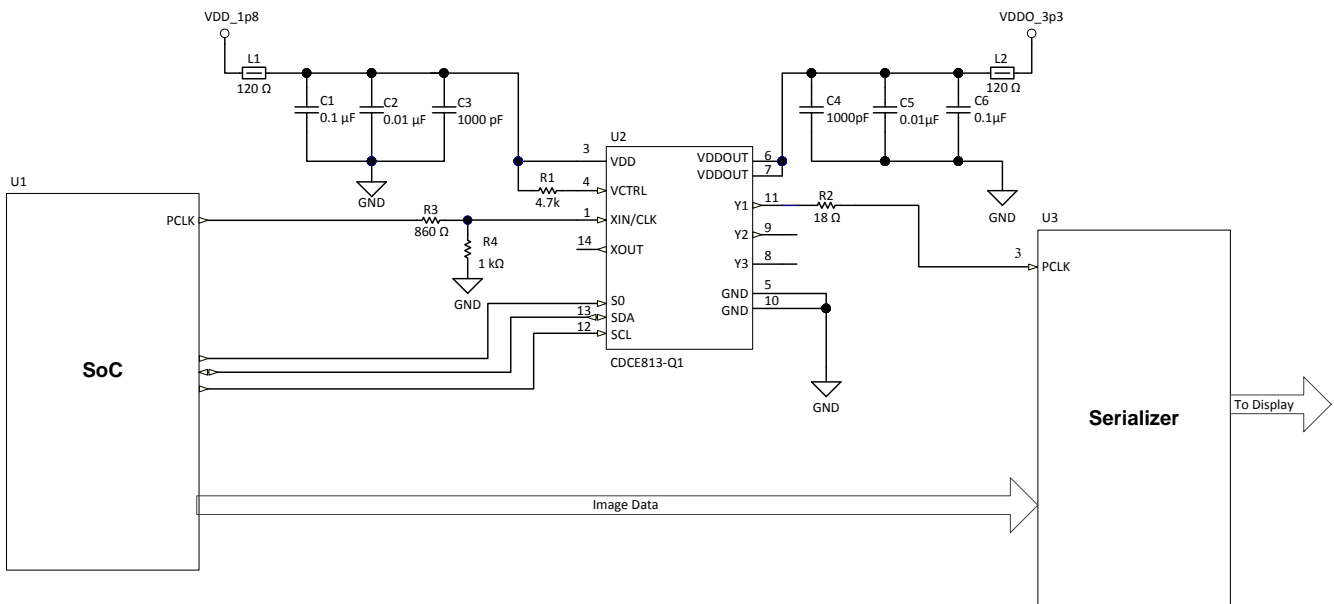

Copyright © 2017, Texas Instruments Incorporated

Figure 13. PCLK Jitter Cleaner Reference Design

10.2.1 Design Requirements

The CDCE813-Q1 device supports spread-spectrum clocking (SSC) with multiple control parameters:

- Modulation amount (%)
- Modulation frequency (>20 kHz)
- Center spread or down spread (\pm or $-$)

Typical Application (continued)

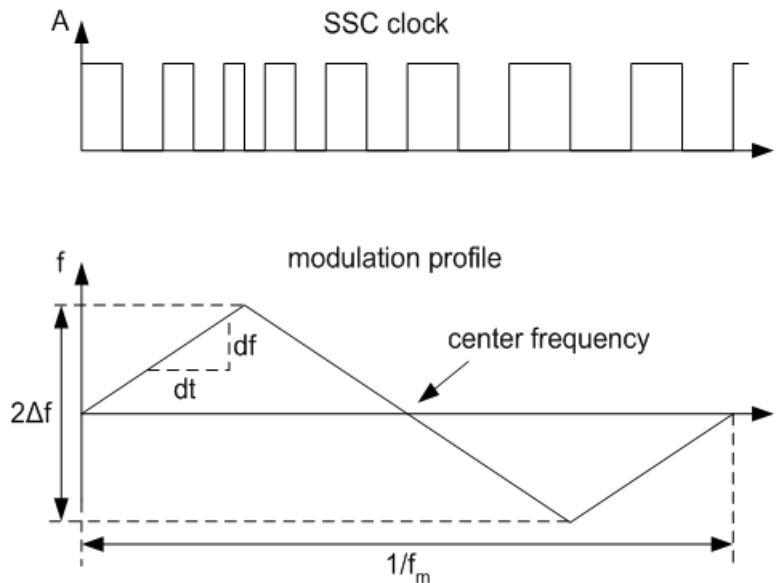
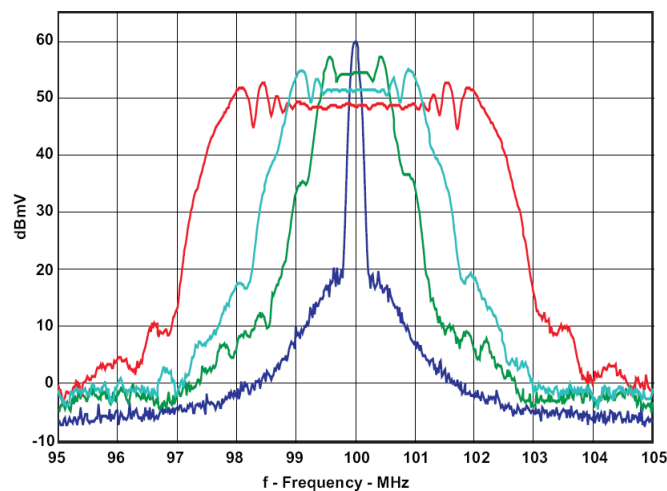

Figure 14. Modulation Frequency (f_m) and Modulation Amount

10.2.2 Detailed Design Procedure

10.2.2.1 Spread-Spectrum Clock (SSC)

Spread-spectrum modulation is a method to spread emitted energy over a larger bandwidth. In clocking, spread spectrum can reduce electromagnetic interference (EMI) by reducing the level of emission from clock distribution network.



CDCS502 with a 25-MHz Crystal, FS = 1, f_{OUT} = 100 MHz, and 0%, ± 0.5 , ± 1 %, and ± 2 % SSC

Figure 15. Comparison Between Typical Clock Power Spectrum and Spread-Spectrum Clock

Spread spectrum clocking can be used to help reduce EMI to meet design specifications. For example, a specified EMI threshold of 55 dB/mV would require ± 1 % spread-spectrum clocking to meet this requirement.

Typical Application (continued)

10.2.2.2 PLL Frequency Planning

At a given input frequency (f_{IN}), the output frequency (f_{OUT}) of the CDCE813-Q1 device is calculated with [Equation 1](#).

$$f_{OUT} = \frac{f_{IN}}{Pdiv} \times \frac{N}{M}$$

- M (1 to 511) and N (1 to 4095) are the multiplier or divider values of the PLL,
- and Pdiv (1 to 127) is the output divider.

(1)

The target VCO frequency (f_{VCO}) of each PLL is calculated with [Equation 2](#).

$$f_{VCO} = f_{IN} \times \frac{N}{M}$$
(2)

The PLL internally operates as fractional divider and needs the following multiplier or divider settings:

- N
- $P = 4 - \text{int}(\log_2 N / M)$; if $P < 0$ then $P = 0$
- $Q = \text{int}(N' / M)$
- $R = N' - M \times Q$

where

- $\text{int}(X)$ = integer portion of X
- $N' = N \times 2^P$
- $N \geq M$

$$80 \text{ MHz} \leq f_{VCO} \leq 230 \text{ MHz}$$

$$16 \leq Q \leq 63$$

$$0 \leq P \leq 4$$

$$0 \leq R \leq 51$$

Example:

for $f_{IN} = 27 \text{ MHz}$; $M = 1$; $N = 4$; $Pdiv = 2$

$$\rightarrow f_{OUT} = 54 \text{ MHz}$$

$$\rightarrow f_{VCO} = 108 \text{ MHz}$$

$$\rightarrow P = 4 - \text{int}(\log_2 4) = 4 - 2 = 2$$

$$\rightarrow N' = 4 \times 2^2 = 16$$

$$\rightarrow Q = \text{int}(16) = 16$$

$$\rightarrow R = 16 - 16 = 0$$

for $f_{IN} = 27 \text{ MHz}$; $M = 2$; $N = 11$; $Pdiv = 2$

$$\rightarrow f_{OUT} = 74.25 \text{ MHz}$$

$$\rightarrow f_{VCO} = 148.50 \text{ MHz}$$

$$\rightarrow P = 4 - \text{int}(\log_2 5.5) = 4 - 2 = 2$$

$$\rightarrow N' = 11 \times 2^2 = 44$$

$$\rightarrow Q = \text{int}(22) = 22$$

$$\rightarrow R = 44 - 44 = 0$$

The values for P, Q, R, and N' are automatically calculated when using TI Pro-Clock™ software.

10.2.2.3 Crystal Oscillator Start-Up

When the CDCE813-Q1 device can be used as a crystal buffer, the crystal oscillator start-up dominates the start-up time compared to the internal PLL lock time. [Figure 16](#) shows the oscillator start-up sequence for a 27-MHz crystal input with an 8-pF load. The start-up time for the crystal is on the order of approximately 250 μs compared to approximately 10 μs of lock time. In general, lock time is an order of magnitude less compared to the crystal start-up time.

Typical Application (continued)



Figure 16. Crystal Oscillator Start-Up vs PLL Lock Time

10.2.2.4 Frequency Adjustment With Crystal Oscillator Pulling

The frequency for the CDCE813-Q1 device is adjusted for media and other applications with the VCXO control input V_{ctr} . If a PWM-modulated signal is used as a control signal for the VCXO, an external filter is needed.

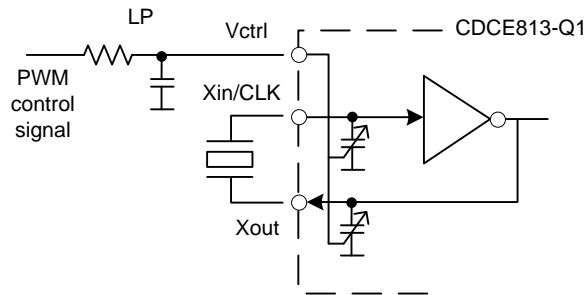

Copyright © 2017, Texas Instruments Incorporated

Figure 17. Frequency Adjustment Using PWM Input to the VCXO Control

10.2.2.5 Unused Inputs and Outputs

If VCXO-pulling functionality is not required, V_{ctr} should be left floating. All other unused inputs should be set to GND. Unused outputs should be left floating.

If one output block is not used, TI recommends disabling it. However, TI recommends providing a supply for all output blocks, even if they are disabled.

10.2.2.6 Switching Between XO and VCXO Mode

When the CDCE813-Q1 device is in the crystal-oscillator or VCXO configuration, the internal capacitors require different internal capacitance. The following steps are recommended to switch to VCXO mode when the configuration for the on-chip capacitor is still set for XO mode. To center the output frequency to 0 ppm:

1. While in XO mode, put $V_{ctr} = V_{DD} / 2$
2. Switch from XO mode to VCXO mode
3. Program the internal capacitors to obtain 0 ppm at the output.

Typical Application (continued)

10.2.3 Application Curves

Figure 18, Figure 19, Figure 20, and Figure 21 show CDCE813-Q1 measurements with the SSC feature enabled. Device configuration: 27-MHz input, 27-MHz output.

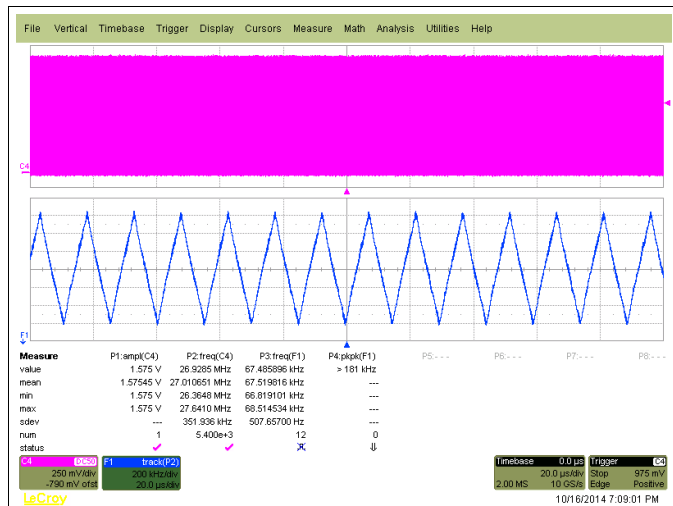

Figure 18. $f_{OUT} = 27$ MHz, VCO frequency < 125 MHz, SSC (2% Center)

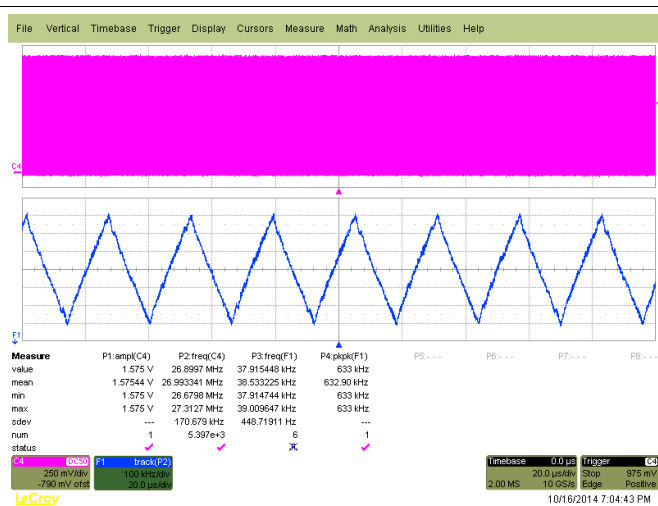

Figure 19. $f_{OUT} = 27$ MHz, VCO frequency > 175 MHz, SSC (1%, Center)

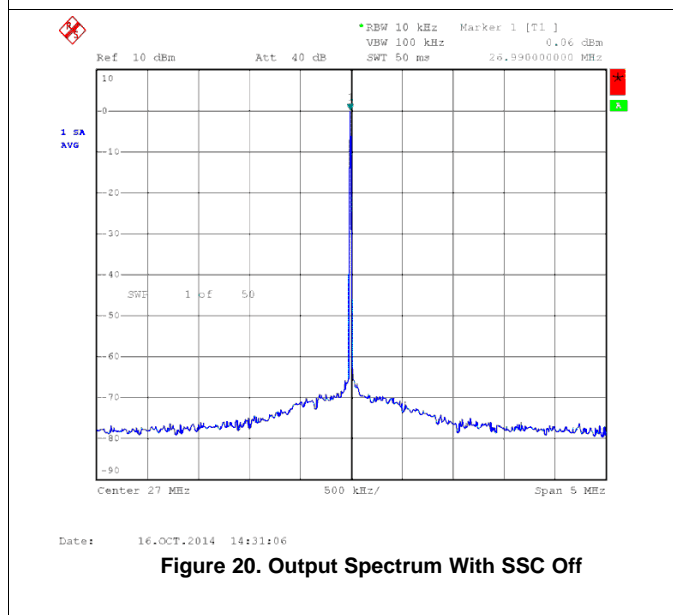

Figure 20. Output Spectrum With SSC Off

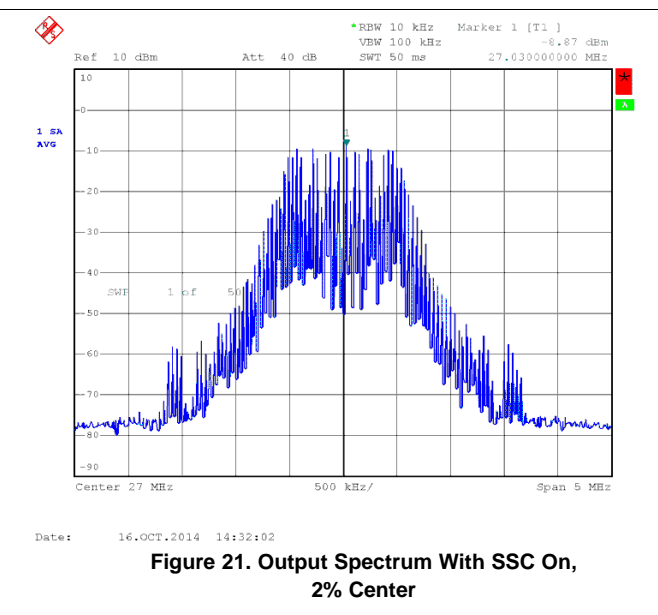

Figure 21. Output Spectrum With SSC On, 2% Center

11 Power Supply Recommendations

There is no restriction on the power-up sequence. In case V_{DDOUT} is applied first, TI recommends grounding the V_{DD} . In case V_{DDOUT} is powered while V_{DD} is floating, there is a risk of high current flowing on the V_{DDOUT} pins.

The device has a power-up control that is connected to the 1.8-V supply. This keeps the whole device disabled until the 1.8-V supply reaches a sufficient voltage level. Then the device switches on all internal components, including the outputs. If a 3.3-V V_{DDOUT} is available before the 1.8-V, the outputs stay disabled until the 1.8-V supply has reached a certain level.

12 Layout

12.1 Layout Guidelines

When the CDCE813-Q1 device is used as a crystal buffer, any parasitic across the crystal affect the pulling range of the VCXO. Therefore, take care in placing the crystal units on the board. Crystals must be placed as close to the device as possible, ensuring that the routing lines from the crystal terminals to Xin and Xout have the same length.

If possible, cut out both ground plane and power plane under the area where the crystal and the routing to the device are placed. In this area, always avoid routing any other signal line, as it could be a source of noise coupling.

Additional discrete capacitors can be required to meet the load capacitance specification of certain crystals. For example, a 10.7-pF load capacitor is not fully programmable on the chip, because the internal capacitor can range from 0 pF to 20 pF with steps of 1 pF. The 0.7-pF capacitor therefore can be discretely added on top of an internal 10-pF capacitor.

To minimize the inductive influence of the trace, TI recommends placing this small capacitor as close to the device as possible and symmetrically with respect to Xin and Xout.

Figure 22 shows a conceptual layout detailing recommended placement of power-supply bypass capacitors. For component-side mounting, use 0402 body-size capacitors to facilitate signal routing. Keep the connections between the bypass capacitors and the power supply on the device as short as possible. Ground the other side of the capacitor using a low-impedance connection to the ground plane.

12.2 Layout Example

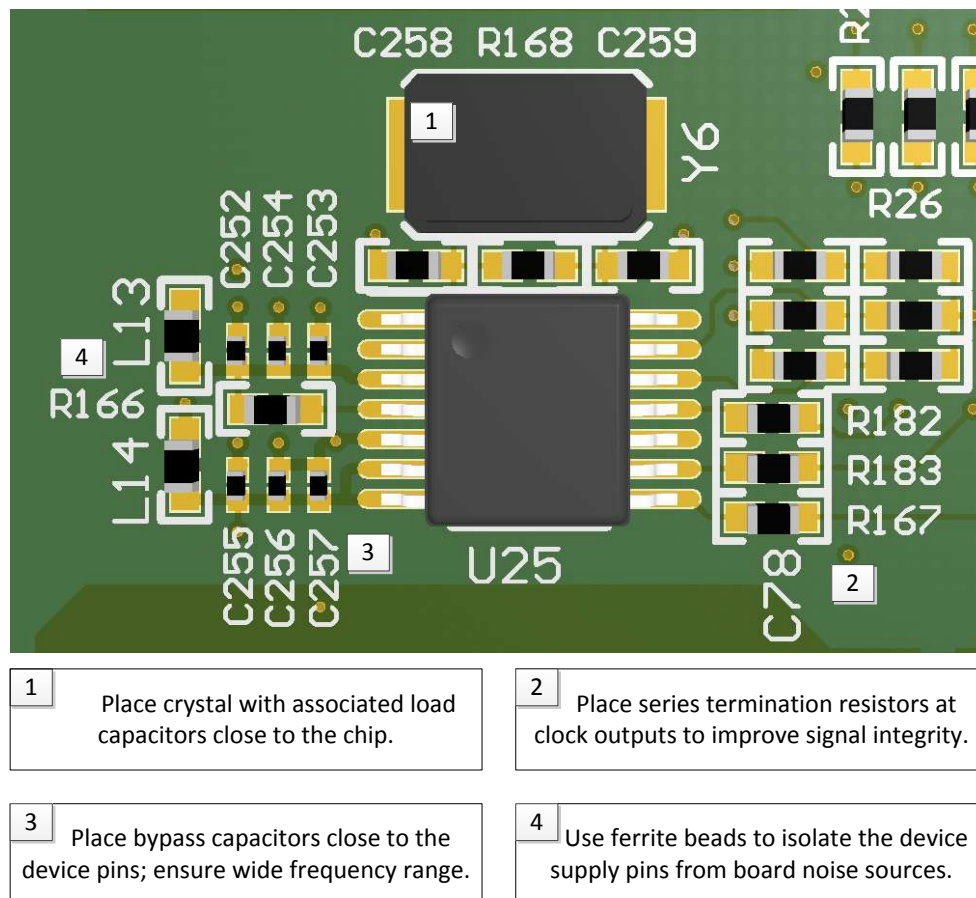

Figure 22. Annotated Layout

13 器件和文档支持

13.1 文档支持

13.1.1 相关文档

请参阅如下相关文档：

- 《面向 CDCE(L)9xx 系列的 VCXO 应用指南》（文献编号：SCAA085）
- 《针对 CDCE(L)9xx 系列选择晶振的实际问题》（文献编号：SLEA071）
- 《针对 CDCE(L)9xx 系列的 I2C/EEPROM 常规使用》（文献编号：SCAA104）
- 《使用硅器件替代晶体或晶体振荡器》（文献编号：SNAA217）
- 《 μ C 在 CDCE(L)949、CDCE(L)937、CDCE(L)925、CDCE(L)813 中的应用》（SCAA105）
- 《使用低频字时钟为音频数据转换器生成低相位噪声时钟》（文献编号：SCAA088）

13.2 接收文档更新通知

要接收文档更新通知，请导航至 TI.com.cn 上的器件产品文件夹。单击右上角的通知我进行注册，即可每周接收产品信息更改摘要。有关更改的详细信息，请查看任何已修订文档中包含的修订历史记录。

13.3 社区资源

下列链接提供到 TI 社区资源的连接。链接的内容由各个分销商“按照原样”提供。这些内容并不构成 TI 技术规范，并且不一定反映 TI 的观点；请参阅 TI 的《使用条款》。

TI E2E™ 在线社区 TI 的工程师对工程师 (E2E) 社区。此社区的创建目的在于促进工程师之间的协作。在 e2e.ti.com 中，您可以咨询问题、分享知识、拓展思路并与同行工程师一道帮助解决问题。

设计支持 TI 参考设计支持 可帮助您快速查找有帮助的 E2E 论坛、设计支持工具以及技术支持的联系信息。

13.4 商标

DaVinci, OMAP, Pro-Clock, E2E are trademarks of Texas Instruments.
Bluetooth is a registered trademark of Bluetooth SIG, Inc.
All other trademarks are the property of their respective owners.

13.5 静电放电警告



这些装置包含有限的内置 ESD 保护。存储或装卸时，应将导线一起截短或将装置放置于导电泡棉中，以防止 MOS 门极遭受静电损伤。

13.6 术语表

SLYZ022 — TI 术语表。

这份术语表列出并解释术语、缩写和定义。

14 机械、封装和可订购信息

以下页面包含机械、封装和可订购信息。这些信息是指定器件的最新可用数据。数据如有变更，恕不另行通知，且不会对此文档进行修订。如需获取此数据表的浏览器版本，请参阅左侧的导航栏。

PACKAGING INFORMATION

Orderable Device	Status (1)	Package Type	Package Drawing	Pins	Package Qty	Eco Plan (2)	Lead/Ball Finish (6)	MSL Peak Temp (3)	Op Temp (°C)	Device Marking (4/5)	Samples
CDCE813QPWRQ1	ACTIVE	TSSOP	PW	14	2000	Green (RoHS & no Sb/Br)	CU NIPDAU	Level-3-260C-168 HR	-40 to 105	CE813Q	Samples
CDCE813R02TPWRQ1	ACTIVE	TSSOP	PW	14	2000	Green (RoHS & no Sb/Br)	CU NIPDAU	Level-3-260C-168 HR	-40 to 105	E813Q02	Samples

(1) The marketing status values are defined as follows:

ACTIVE: Product device recommended for new designs.

LIFEBUY: TI has announced that the device will be discontinued, and a lifetime-buy period is in effect.

NRND: Not recommended for new designs. Device is in production to support existing customers, but TI does not recommend using this part in a new design.

PREVIEW: Device has been announced but is not in production. Samples may or may not be available.

OBsolete: TI has discontinued the production of the device.

(2) **RoHS:** TI defines "RoHS" to mean semiconductor products that are compliant with the current EU RoHS requirements for all 10 RoHS substances, including the requirement that RoHS substance do not exceed 0.1% by weight in homogeneous materials. Where designed to be soldered at high temperatures, "RoHS" products are suitable for use in specified lead-free processes. TI may reference these types of products as "Pb-Free".

RoHS Exempt: TI defines "RoHS Exempt" to mean products that contain lead but are compliant with EU RoHS pursuant to a specific EU RoHS exemption.

Green: TI defines "Green" to mean the content of Chlorine (Cl) and Bromine (Br) based flame retardants meet JS709B low halogen requirements of <=1000ppm threshold. Antimony trioxide based flame retardants must also meet the <=1000ppm threshold requirement.

(3) MSL, Peak Temp. - The Moisture Sensitivity Level rating according to the JEDEC industry standard classifications, and peak solder temperature.

(4) There may be additional marking, which relates to the logo, the lot trace code information, or the environmental category on the device.

(5) Multiple Device Markings will be inside parentheses. Only one Device Marking contained in parentheses and separated by a "~" will appear on a device. If a line is indented then it is a continuation of the previous line and the two combined represent the entire Device Marking for that device.

(6) Lead/Ball Finish - Orderable Devices may have multiple material finish options. Finish options are separated by a vertical ruled line. Lead/Ball Finish values may wrap to two lines if the finish value exceeds the maximum column width.

Important Information and Disclaimer:The information provided on this page represents TI's knowledge and belief as of the date that it is provided. TI bases its knowledge and belief on information provided by third parties, and makes no representation or warranty as to the accuracy of such information. Efforts are underway to better integrate information from third parties. TI has taken and continues to take reasonable steps to provide representative and accurate information but may not have conducted destructive testing or chemical analysis on incoming materials and chemicals. TI and TI suppliers consider certain information to be proprietary, and thus CAS numbers and other limited information may not be available for release.

In no event shall TI's liability arising out of such information exceed the total purchase price of the TI part(s) at issue in this document sold by TI to Customer on an annual basis.

TAPE AND REEL INFORMATION



QUADRANT ASSIGNMENTS FOR PIN 1 ORIENTATION IN TAPE



*All dimensions are nominal

Device	Package Type	Package Drawing	Pins	SPQ	Reel Diameter (mm)	Reel Width W1 (mm)	A0 (mm)	B0 (mm)	K0 (mm)	P1 (mm)	W (mm)	Pin1 Quadrant
CDCE813QPWRQ1	TSSOP	PW	14	2000	330.0	12.4	6.9	5.6	1.6	8.0	12.0	Q1
CDCE813R02TPWRQ1	TSSOP	PW	14	2000	330.0	12.4	6.9	5.6	1.6	8.0	12.0	Q1

TAPE AND REEL BOX DIMENSIONS

*All dimensions are nominal

Device	Package Type	Package Drawing	Pins	SPQ	Length (mm)	Width (mm)	Height (mm)
CDCE813QPWRQ1	TSSOP	PW	14	2000	367.0	367.0	35.0
CDCE813R02TPWRQ1	TSSOP	PW	14	2000	367.0	367.0	35.0

PW (R-PDSO-G14)

PLASTIC SMALL OUTLINE



- NOTES:
- All linear dimensions are in millimeters.
 - This drawing is subject to change without notice.
 - Publication IPC-7351 is recommended for alternate designs.
 - Laser cutting apertures with trapezoidal walls and also rounding corners will offer better paste release. Customers should contact their board assembly site for stencil design recommendations. Refer to IPC-7525 for other stencil recommendations.
 - Customers should contact their board fabrication site for solder mask tolerances between and around signal pads.

重要声明和免责声明

TI 均以“原样”提供技术性数据（包括数据表）、设计资源（包括参考设计）、应用或其他设计建议、网络工具、安全信息和其他资源，不保证其中不含任何瑕疵，且不做任何明示或暗示的担保，包括但不限于对适销性、适合某特定用途或不侵犯任何第三方知识产权的暗示担保。

所述资源可供专业开发人员应用TI 产品进行设计使用。您将对以下行为独自承担全部责任：(1) 针对您的应用选择合适的TI 产品；(2) 设计、验证并测试您的应用；(3) 确保您的应用满足相应标准以及任何其他安全、安保或其他要求。所述资源如有变更，恕不另行通知。TI 对您使用所述资源的授权仅限于开发资源所涉及TI 产品的相关应用。除此之外不得复制或展示所述资源，也不提供其它TI 或任何第三方的知识产权授权许可。如因使用所述资源而产生任何索赔、赔偿、成本、损失及债务等，TI 对此概不负责，并且您须赔偿由此对TI 及其代表造成的损害。

TI 所提供产品均受TI 的销售条款 (<http://www.ti.com.cn/zh-cn/legal/termsofsale.html>) 以及ti.com.cn上或随附TI产品提供的其他可适用条款的约束。TI提供所述资源并不扩展或以其他方式更改TI 针对TI 产品所发布的可适用的担保范围或担保免责声明。

邮寄地址：上海市浦东新区世纪大道 1568 号中建大厦 32 楼，邮政编码：200122
Copyright © 2019 德州仪器半导体技术（上海）有限公司