

## 16 位、4 通道 CCD/CMOS 传感器 具有定时发生器的模拟前端

查询样品: [VSP5610](#), [VSP5611](#), [VSP5612](#)

### 特性

- 四通道 **CCD/CMOS** 信号: **2 通道、4 通道或 4 通道** (可选)
- 电源: 仅限 **3.3V** (典型值)  
(内置 **LDO, 3.3V 至 1.8V**)
- 最大转换速率:
  - **VSP5610: 35 MSPS**
  - **VSP5611: 50 MSPS**
  - **VSP5612: 70 MSPS**
- **16 位** 分辨率
- **CDS/SH** (可选)
- 最大输入信号范围: **2.0V**
- 模拟和数字混合增益:
  - 模拟增益: **3/64-V/V** 步骤中为 **0.5V/V 至 3.5V/V**
  - 数字增益: **1/256-V/V** 步骤中为 **1V/V 至 2V/V**
- 偏移校正 **DAC: ±250mV、8 位**
- 标准 **LVDS/CMOS** 可选输出:
  - **LVDS:**
    - 数据通道: **2 通道、3 通道**
    - 时钟通道: **1 通道**
    - **8 位/7 位** 串行器 (可选)
  - **CMOS: 4 位 × 4、8 位 × 2**
- 定时发生器:
  - 快速传输时钟: 八个信号
  - 慢速传输时钟: 六个信号
- 定时调节分辨率: **t<sub>MCLK</sub>/48**
- 输入钳位/输入参考级别内部/外部 (可选)
- 参考 **DAC: 0.5V、1.1V、1.5V、2V**
- **SPI™**: 三线串行
- **GPIO**: 四端口

### 应用

- 复印机
- 传真机
- 扫描仪

### 说明

VSP5610/11/12 为高速、高性能 **16 位** 模数转换器 (ADC), 具有四个独立的采样电路通道, 用于多路输出充电耦合设备 (CCD) 及互补金属氧化物半导体 (CMOS) 系列传感器。传感器的像素数据由采样/保持 (SH) 或相关双采样 (CDS) 电路采样, 然后由 ADC 转化为数字数据。数据输出在低电压差动信号 (LVDS) 或 CMOS 模式下可选。

VSP5610/11/12 包括一个可编程增益, 支持亮度引起的像素级反射。集成数模转换器 (DAC) 可用于调节模拟输入信号的偏移级别。此外, 定时发生器 (TG) 和一些控制传感器运行的器件集成。

VSP5610/11/12 使用 **1.65V 至 1.95V** 用于内核电压, **3.0V 至 3.6V** 用于 I/O。内核电压由内置低压降稳压器 (LDO) 提供。



Please be aware that an important notice concerning availability, standard warranty, and use in critical applications of Texas Instruments semiconductor products and disclaimers thereto appears at the end of this data sheet.

SPI is a trademark of Motorola.

All other trademarks are the property of their respective owners.



This integrated circuit can be damaged by ESD. Texas Instruments recommends that all integrated circuits be handled with appropriate precautions. Failure to observe proper handling and installation procedures can cause damage.

ESD damage can range from subtle performance degradation to complete device failure. Precision integrated circuits may be more susceptible to damage because very small parametric changes could cause the device not to meet its published specifications.

### PACKAGE/ORDERING INFORMATION<sup>(1)</sup>

PRODUCT	PACKAGE-LEAD	PACKAGE DESIGNATOR	SPECIFIED TEMPERATURE RANGE	PACKAGE MARKING	ORDERING NUMBER	TRANSPORT MEDIA
VSP5610	QFN-56	RSH	0°C to +85°C	VSP5610	VSP5610RSHR	Tape and Reel
VSP5611	QFN-56	RSH	0°C to +85°C	VSP5611	VSP5611RSHR	Tape and Reel
VSP5612	QFN-56	RSH	0°C to +85°C	VSP5612	VSP5612RSHR	Tape and Reel

(1) For the most current package and ordering information, see the Package Option Addendum at the end of this document, or visit the device product folder at [www.ti.com](http://www.ti.com).

### ABSOLUTE MAXIMUM RATINGS<sup>(1)</sup>

Over operating free-air temperature range, unless otherwise noted.

	VSP5610, VSP5611, VSP5612	UNIT
Supply voltage: VDD, DVDD_IO, LVDD	4.0	V
Supply voltage difference: VDD, DVDD_IO, LVDD	±0.6	V
Ground voltage difference: VSS, DVSS, LVSS	±0.1	V
Digital voltage input	−0.3 to DVDD_IO + 0.3	V
Analog voltage input	−0.3 to VDD + 0.3	V
Digital input current	±10	mA
Analog input current	±10	mA
Ambient temperature under bias	−40 to +125	°C
Storage temperature	−55 to +150	°C
Junction temperature	+150	°C
Package temperature (IR reflow, peak)	+260	°C

(1) Stresses beyond those listed under *absolute maximum ratings* may cause permanent damage to the device. These are stress ratings only and functional operation of the device at these or any other conditions beyond those indicated under *recommended operating conditions* is not implied. Exposure to absolute-maximum-rated conditions for extended periods may affect device reliability.

### RECOMMENDED OPERATING CONDITIONS

		MIN	NOM	MAX	UNIT
LDO and analog I/O power-supply voltage	VDD	3.0	3.3	3.6	V
Digital power-supply voltage	DVDD_IO	3.0	3.3	3.6	V
LVDS/CMOS power-supply voltage	LVDD	3.0	3.3	3.6	V
Supply voltage difference	VDD, DVDD_IO, LVDD	−0.3		0.3	V
Digital input logic family		Low-voltage CMOS			
Master clock frequency (MCLK)	VSP5610	1		11.66	MHz
	VSP5611	1		16.66	MHz
	VSP5612	1		23.33	MHz
Serial I/O clock frequency (SCLK)				10	MHz
Operating free-air temperature		0		+85	°C

**ELECTRICAL CHARACTERISTICS: VSP5610**

All specifications at  $T_A = +25^\circ\text{C}$ , supply voltage = +3.3 V, conversion rate = 8.75 MHz, and four-channel mode, unless otherwise noted.

PARAMETER	TEST CONDITIONS	VSP5610			UNIT	
		MIN	TYP	MAX		
<b>ANALOG INPUT</b>						
Allowable input voltage		0		VDD	V	
Full-scale range	Gain = 1 V/V		1		$V_{PP}$	
Input capacitor			5		pF	
<b>DIGITAL INPUT</b>						
Positive-going threshold	$V_{T+}$		DVDD_IO × 0.7		V	
Negative-going threshold	$V_{T-}$	DVDD_IO × 0.3			V	
Hysteresis ( $V_{T+} - V_{T-}$ )	$\Delta V_T$	DVDD_IO × 0.13			V	
Input current	$I_{IN}$			±1	μA	
Input capacitor			5		pF	
<b>DIGITAL OUTPUT</b>						
High-level output voltage	$V_{OH}$	$I_{OH} = -2\text{ mA}$	DVDD_IO – 0.45		V	
		$I_{OH} = -4\text{ mA}$	DVDD_IO – 0.50		V	
		$I_{OH} = -8\text{ mA}$	DVDD_IO – 0.50		V	
Low-level output voltage	$V_{OL}$	$I_{OL} = 2\text{ mA}$	0.35		V	
		$I_{OL} = 4\text{ mA}$	0.50		V	
		$I_{OL} = 8\text{ mA}$	0.65		V	
TG output timing skew		XP1, XP2, XP3, XP4	–1	1	ns	
		Other signals	–2	2	ns	
CMOS data output bit rate				80	MHz	
<b>LVDS DRIVER (TA, TB, TC, TCLK)</b>						
Differential steady-state output voltage adjustment range	$ V_{OD} $	$R_L = 100\ \Omega$	300	350	400	mV
Differential steady-state output adjustment step	$ V_{OD} $		3		Steps	
Differential steady-state output voltage tolerance	$ V_{OD} $		–30	30	%	
Change in the steady-state differential output voltage magnitude between opposite binary states	$\Delta V_{OD} $			35	mV	
Steady-state common-mode output voltage	$V_{OC(SS)}$	$R_L = 100\ \Omega$	1.125	1.375	V	
Peak-to-peak common-mode output voltage	$V_{OC(PP)}$		80	150	mV	
Short-circuit output current	$I_{OS}$	$V_O = 0\text{ V}$ ( $V_O = TA, TB, TC, TCLK$ )	–6	±24	mA	
Hi-Z output current	$I_{OZ}$	$V_O = 0\text{ V}$ to LVDD ( $V_O = TA, TB, TC, TCLK$ )		±10	μA	
Transition time, differential output voltage	$t_{LR}/t_{LF}$		0.75	1.5	ns	
TCLK clock rate			8	35	MHz	
<b>LVDS RECEIVER (RCLK)</b>						
Positive-going differential input threshold voltage	$V_{IT+}$			100	mV	
Negative-going differential input threshold voltage	$V_{IT-}$		–100		mV	
RCLK clock rate			1	11.66	MHz	

## ELECTRICAL CHARACTERISTICS: VSP5610 (continued)

All specifications at  $T_A = +25^\circ\text{C}$ , supply voltage = +3.3 V, conversion rate = 8.75 MHz, and four-channel mode, unless otherwise noted.

PARAMETER	TEST CONDITIONS	VSP5610			UNIT	
		MIN	TYP	MAX		
<b>POWER SUPPLY</b>						
LDO and analog I/O supply voltage	VDD	3.0	3.3	3.6	V	
Digital I/O supply voltage	DVDD_IO	3.0	3.3	3.6	V	
LVDS/CMOS supply voltage	LVDD	3.0	3.3	3.6	V	
LDO and analog I/O current	VDD	74.9			mA	
Digital I/O current	DVDD_IO	Load = 10 pF			mA	
CMOS current	LVDD	10			mA	
LVDS current	LVDD	Three-pair data, one-pair clock			mA	
Power consumption	LVDS, three-pair		339		mW	
	CMOS output		317		mW	
	Standby mode (MCLK = 0 MHz)		15		mW	
<b>TEMPERATURE RANGE</b>						
Operation temperature	$T_A$	0		+85	$^\circ\text{C}$	
Thermal resistor (junction-to-air)	$\theta_{JA}$	PCB (50 mm × 50 mm, four-layer), 0 lfm airflow		29	$^\circ\text{C/W}$	
Thermal resistor (junction-to-case)	$\theta_{JC}$			24	$^\circ\text{C/W}$	
<b>DLL, PLL</b>						
MCLK input frequency	$f_{MCLK}$	1		11.66	MHz	
MCLK modulated frequency	MCLK > 5 MHz		35		kHz	
MCLK modulated amplitude			-3.5		0	%
DLL tap number			48		Taps	
Maximum DLL and PLL lock-up time	MCLK = 1 MHz		10		ms	
<b>TRANSFER CHARACTERISTICS</b>						
Channels			2		4	Channels
Resolution			16			Bits
Conversion rate	LVDS, two- and three-channel mode		1		11.66	MHz/Ch
	LVDS, four-channel mode		1		8.75	MHz/Ch
	CMOS 8-bit × 2, two-channel mode		1		11.66	MHz/Ch
	CMOS 4-bit × 4, two-channel mode		1		10	MHz/Ch
	CMOS 8-bit × 2, three-channel mode		1		11.66	MHz/Ch
	CMOS 4-bit × 4, three-channel mode		1		6.7	MHz/Ch
	CMOS 8-bit × 2, four-channel mode		1		8.75	MHz/Ch
	CMOS 4-bit × 4, four-channel mode		1		5	MHz/Ch
Maximum differential nonlinearity	Gain = 1 V/V, 12-bit		±0.5			LSB
Maximum integral nonlinearity	Gain = 1 V/V, 12-bit		±2			LSB
No missing codes			Specified			
Signal-to-noise ratio	SNR	Gain = 1 V/V		72 <sup>(1)</sup>	76	dB
Analog channel crosstalk	Gain = 1 V/V, 12-bit, full-scale step		±3			LSB
Total absolute gain error			-10		10	%

(1) Specified by design.

**ELECTRICAL CHARACTERISTICS: VSP5610 (continued)**

All specifications at  $T_A = +25^\circ\text{C}$ , supply voltage = +3.3 V, conversion rate = 8.75 MHz, and four-channel mode, unless otherwise noted.

PARAMETER	TEST CONDITIONS	VSP5610			UNIT	
		MIN	TYP	MAX		
<b>ANALOG PROGRAMMABLE GAIN (APG)</b>						
Gain range	APG_x	0.5		3.5	V/V	
Gain step			63		Steps	
Gain relative error	Basis gain = 1 V/V	-10		10	%	
Gain monotonicity	Only APG_x		Specified			
<b>DIGITAL PROGRAMMABLE GAIN (DPG)</b>						
Gain range	DPG_x	1.0		2.0	V/V	
Gain step			255		Steps	
Gain monotonicity	Only DPG_x		Specified			
<b>AIN REFERENCE LEVEL (REF_AIN)</b>						
Internal DAC output	$V_{\text{RINT}}$	Setting code = 2		0.5	V	
		Setting code = 3		1.1	V	
		Setting code = 0 (default)		1.5	V	
		Setting code = 1		2.0	V	
Internal DAC output tolerance	$V_{\text{RINT}}$	-10		10	%	
Internal DAC output temperature drift	$V_{\text{RINT}}$	$T_A = 0^\circ\text{C to } +85^\circ\text{C}^{(2)}$		-2	2	%
External reference range	$V_{\text{REXT}}$	0.5		$V_{\text{DD}} - 0.9$	V	
<b>INPUT CLAMP</b>						
Clamp level	$V_{\text{CLP}}$	Internal reference level clamp		$V_{\text{RINT}}$	V	
		External reference level clamp		$V_{\text{REXT}}$	V	
		Fixed level clamp		2.2	V	
Clamp-on resistance	$R_{\text{CLP}}$			500	$\Omega$	
<b>OFFSET DAC</b>						
Resolution			8		Bits	
Output range			$\pm 250$		mV	
Setting tolerance		-10		10	%	
Temperature drift		$T_A = 0^\circ\text{C to } +85^\circ\text{C}^{(2)}$		-2	2	%

(2) Specified by design.

## ELECTRICAL CHARACTERISTICS: VSP5611

All specifications at  $T_A = +25^\circ\text{C}$ , supply voltage = +3.3 V, conversion rate = 12.5 MHz, and four-channel mode, unless otherwise noted.

PARAMETER	TEST CONDITIONS	VSP5611			UNIT	
		MIN	TYP	MAX		
<b>ANALOG INPUT</b>						
Allowable input voltage		0		VDD	V	
Full-scale range	Gain = 1 V/V		1		$V_{PP}$	
Input capacitor			5		pF	
<b>DIGITAL INPUT</b>						
Positive-going threshold	$V_{T+}$			$DVDD\_IO \times 0.7$	V	
Negative-going threshold	$V_{T-}$	$DVDD\_IO \times 0.3$			V	
Hysteresis ( $V_{T+} - V_{T-}$ )	$\Delta V_T$			$DVDD\_IO \times 0.13$	V	
Input current	$I_{IN}$			$\pm 1$	$\mu\text{A}$	
Input capacitor			5		pF	
<b>DIGITAL OUTPUT</b>						
High-level output voltage	$V_{OH}$	$I_{OH} = -2 \text{ mA}$		$DVDD\_IO - 0.45$	V	
		$I_{OH} = -4 \text{ mA}$		$DVDD\_IO - 0.50$	V	
		$I_{OH} = -8 \text{ mA}$		$DVDD\_IO - 0.50$	V	
Low-level output voltage	$V_{OL}$	$I_{OL} = 2 \text{ mA}$		0.35	V	
		$I_{OL} = 4 \text{ mA}$		0.50	V	
		$I_{OL} = 8 \text{ mA}$		0.65	V	
TG output timing skew		XP1, XP2, XP3, XP4	-1	1	ns	
		Other signals	-2	2	ns	
CMOS data output bit rate				80	MHz	
<b>LVDS DRIVER (TA, TB, TC, TCLK)</b>						
Differential steady-state output voltage adjustment range	$ V_{OD} $	$R_L = 100 \Omega$	300	350	400	mV
Differential steady-state output adjustment step	$ V_{OD} $			3		Steps
Differential steady-state output voltage tolerance	$ V_{OD} $		-30		30	%
Change in the steady-state differential output voltage magnitude between opposite binary states	$\Delta V_{OD} $				35	mV
Steady-state common-mode output voltage	$V_{OC(SS)}$	$R_L = 100 \Omega$	1.125		1.375	V
Peak-to-peak common-mode output voltage	$V_{OC(PP)}$			80	150	mV
Short-circuit output current	$I_{OS}$	$V_O = 0 \text{ V}$ ( $V_O = TA, TB, TC, TCLK$ )		-6	$\pm 24$	mA
Hi-Z output current	$I_{OZ}$	$V_O = 0 \text{ V}$ to LVDD ( $V_O = TA, TB, TC, TCLK$ )			$\pm 10$	$\mu\text{A}$
Transition time, differential output voltage	$t_{LR}/t_{LF}$			0.75	1.5	ns
TCLK clock rate			8		50	MHz
<b>LVDS RECEIVER (RCLK)</b>						
Positive-going differential input threshold voltage	$V_{IT+}$				100	mV
Negative-going differential input threshold voltage	$V_{IT-}$		-100			mV
RCLK clock rate			1		16.66	MHz

**ELECTRICAL CHARACTERISTICS: VSP5611 (continued)**

All specifications at  $T_A = +25^\circ\text{C}$ , supply voltage = +3.3 V, conversion rate = 12.5 MHz, and four-channel mode, unless otherwise noted.

PARAMETER	TEST CONDITIONS	VSP5611			UNIT
		MIN	TYP	MAX	
<b>POWER SUPPLY</b>					
LDO and analog I/O supply voltage	VDD	3.0	3.3	3.6	V
Digital I/O supply voltage	DVDD_IO	3.0	3.3	3.6	V
LVDS/CMOS supply voltage	LVDD	3.0	3.3	3.6	V
LDO and analog I/O current	VDD	99.6			mA
Digital I/O current	DVDD_IO	Load = 10 pF			mA
CMOS current	LVDD	10			mA
LVDS current	LVDD	Three-pair data, one-pair clock			mA
Power consumption	LVDS, three-pair		426		mW
	CMOS output		398		mW
	Standby mode (MCLK = 0 MHz)		15		mW
<b>TEMPERATURE RANGE</b>					
Operation temperature	$T_A$	0	+85		$^\circ\text{C}$
Thermal resistor (junction-to-air)	$\theta_{JA}$	PCB (50 mm × 50 mm, four-layer), 0 lfm airflow		29	$^\circ\text{C}/\text{W}$
Thermal resistor (junction-to-case)	$\theta_{JC}$			24	$^\circ\text{C}/\text{W}$
<b>DLL, PLL</b>					
MCLK input frequency	$f_{\text{MCLK}}$	1	16.66		MHz
MCLK modulated frequency	MCLK > 5 MHz		35		kHz
MCLK modulated amplitude			-3.5	0	%
DLL tap number			48		Taps
Maximum DLL and PLL lock-up time	MCLK = 1 MHz		10		ms
<b>TRANSFER CHARACTERISTICS</b>					
Channel			2	4	Channels
Resolution			16		Bits
Conversion rate	LVDS, two- and three-channel mode		1	16.66	MHz/Ch
	LVDS, four-channel mode		1	12.5	MHz/Ch
	CMOS 8-bit × 2, two-channel mode		1	16.66	MHz/Ch
	CMOS 4-bit × 4, two-channel mode		1	10	MHz/Ch
	CMOS 8-bit × 2, three-channel mode		1	13.3	MHz/Ch
	CMOS 4-bit × 4, three-channel mode		1	6.7	MHz/Ch
	CMOS 8-bit × 2, four-channel mode		1	10	MHz/Ch
	CMOS 4-bit × 4, four-channel mode		1	5	MHz/Ch
Maximum differential nonlinearity	Gain = 1 V/V, 12-bit		±0.5		LSB
Maximum integral nonlinearity	Gain = 1 V/V, 12-bit		±2		LSB
No missing codes			Specified		
Signal-to-noise ratio	SNR	Gain = 1 V/V		72 <sup>(1)</sup>	dB
Analog channel crosstalk	Gain = 1 V/V, 12-bit, full-scale step		±6.5		LSB
Total absolute gain error			-10	10	%

(1) Specified by design.

## ELECTRICAL CHARACTERISTICS: VSP5611 (continued)

All specifications at  $T_A = +25^\circ\text{C}$ , supply voltage = +3.3 V, conversion rate = 12.5 MHz, and four-channel mode, unless otherwise noted.

PARAMETER	TEST CONDITIONS	VSP5611			UNIT	
		MIN	TYP	MAX		
<b>ANALOG PROGRAMMABLE GAIN (APG)</b>						
Gain range	APG_x	0.5		3.5	V/V	
Gain step			63		Steps	
Gain relative error	Basis gain = 1 V/V	-10		10	%	
Gain monotonicity	Only APG_x		Specified			
<b>DIGITAL PROGRAMMABLE GAIN (DPG)</b>						
Gain range	DPG_x	1.0		2.0	V/V	
Gain step			255		Steps	
Gain monotonicity	Only DPG_x		Specified			
<b>AIN REFERENCE LEVEL (REF_AIN)</b>						
Internal DAC output	$V_{\text{RINT}}$	Setting code = 2		0.5	V	
		Setting code = 3		1.1	V	
		Setting code = 0 (default)		1.5	V	
		Setting code = 1		2.0	V	
Internal DAC output tolerance	$V_{\text{RINT}}$	-10		10	%	
Internal DAC output temperature drift	$V_{\text{RINT}}$	$T_A = 0^\circ\text{C}$ to $+85^\circ\text{C}^{(2)}$		-2	2	%
External reference range	$V_{\text{REXT}}$	0.5		$V_{\text{DD}} - 0.9$	V	
<b>INPUT CLAMP</b>						
Clamp level	$V_{\text{CLP}}$	Internal reference level clamp		$V_{\text{RINT}}$	V	
		External reference level clamp		$V_{\text{REXT}}$	V	
		Fixed level clamp		2.2	V	
Clamp-on resistance	$R_{\text{CLP}}$			500	$\Omega$	
<b>OFFSET DAC</b>						
Resolution			8		Bits	
Output range			$\pm 250$		mV	
Setting tolerance		-10		10	%	
Temperature drift		$T_A = 0^\circ\text{C}$ to $+85^\circ\text{C}^{(2)}$		-2	2	%

(2) Specified by design.

**ELECTRICAL CHARACTERISTICS: VSP5612**

All specifications at  $T_A = +25^\circ\text{C}$ , supply voltage = +3.3 V, conversion rate = 17.5 MHz, and four-channel mode, unless otherwise noted.

PARAMETER	TEST CONDITIONS	VSP5612			UNIT	
		MIN	TYP	MAX		
<b>ANALOG INPUT</b>						
Allowable input voltage		0		VDD	V	
Full-scale range	Gain = 1 V/V		1		$V_{PP}$	
Input capacitor			5		pF	
<b>DIGITAL INPUT</b>						
Positive-going threshold	$V_{T+}$		DVDD_IO × 0.7		V	
Negative-going threshold	$V_{T-}$	DVDD_IO × 0.3			V	
Hysteresis ( $V_{T+} - V_{T-}$ )	$\Delta V_T$	DVDD_IO × 0.13			V	
Input current	$I_{IN}$			±1	μA	
Input capacitor			5		pF	
<b>DIGITAL OUTPUT</b>						
High-level output voltage	$V_{OH}$	$I_{OH} = -2\text{ mA}$	DVDD_IO – 0.45		V	
		$I_{OH} = -4\text{ mA}$	DVDD_IO – 0.50		V	
		$I_{OH} = -8\text{ mA}$	DVDD_IO – 0.50		V	
Low-level output voltage	$V_{OL}$	$I_{OL} = 2\text{ mA}$	0.35		V	
		$I_{OL} = 4\text{ mA}$	0.50		V	
		$I_{OL} = 8\text{ mA}$	0.65		V	
TG output timing skew		XP1, XP2, XP3, XP4	–1	1	ns	
		Other signals	–2	2	ns	
CMOS data output bit rate				80	MHz	
<b>LVDS DRIVER (TA, TB, TC, TCLK)</b>						
Differential steady-state output voltage adjustment range	$ V_{OD} $	$R_L = 100\ \Omega$	300	350	400	mV
Differential steady-state output adjustment step	$ V_{OD} $		3		Steps	
Differential steady-state output voltage tolerance	$ V_{OD} $		–30	30	%	
Change in the steady-state differential output voltage magnitude between opposite binary states	$\Delta V_{OD} $			35	mV	
Steady-state common-mode output voltage	$V_{OC(SS)}$	$R_L = 100\ \Omega$	1.125	1.375	V	
Peak-to-peak common-mode output voltage	$V_{OC(PP)}$		80	150	mV	
Short-circuit output current	$I_{OS}$	$V_O = 0\text{ V}$ ( $V_O = TA, TB, TC, TCLK$ )	–6	±24	mA	
Hi-Z output current	$I_{OZ}$	$V_O = 0\text{ V}$ to LVDD ( $V_O = TA, TB, TC, TCLK$ )		±10	μA	
Transition time, differential output voltage	$t_{LR}/t_{LF}$		0.75	1.5	ns	
TCLK clock rate			8	70	MHz	
<b>LVDS RECEIVER (RCLK)</b>						
Positive-going differential input threshold voltage	$V_{IT+}$			100	mV	
Negative-going differential input threshold voltage	$V_{IT-}$		–100		mV	
RCLK clock rate			1	23.33	MHz	

### ELECTRICAL CHARACTERISTICS: VSP5612 (continued)

All specifications at  $T_A = +25^\circ\text{C}$ , supply voltage = +3.3 V, conversion rate = 17.5 MHz, and four-channel mode, unless otherwise noted.

PARAMETER	TEST CONDITIONS	VSP5612			UNIT
		MIN	TYP	MAX	
<b>POWER SUPPLY</b>					
LDO and analog I/O supply voltage	VDD	3.0	3.3	3.6	V
Digital I/O supply voltage	DVDD_IO	3.0	3.3	3.6	V
LVDS/CMOS supply voltage	LVDD	3.0	3.3	3.6	V
LDO and analog I/O current	VDD		133		mA
Digital I/O current	DVDD_IO	Load = 10 pF		7.5	mA
CMOS current	LVDD		10		mA
LVDS current	LVDD	Three-pair data, one-pair clock		24	mA
Power consumption		LVDS, three-pair		542	mW
		CMOS output		507	mW
		Standby mode (MCLK = 0 MHz)		15	mW
<b>TEMPERATURE RANGE</b>					
Operation temperature	$T_A$	0		+85	$^\circ\text{C}$
Thermal resistor (junction-to-air)	$\theta_{JA}$	PCB (50 mm × 50 mm, four-layer), 0 lfm airflow		29	$^\circ\text{C/W}$
Thermal resistor (junction-to-case)	$\theta_{JC}$			24	$^\circ\text{C/W}$
<b>DLL, PLL</b>					
MCLK input frequency	$f_{MCLK}$	1		23.33	MHz
MCLK modulated frequency		MCLK > 5 MHz		35	kHz
MCLK modulated amplitude		-3.5		0	%
DLL tap number			48		Taps
Maximum DLL and PLL lock-up time		MCLK = 1 MHz		10	ms
<b>TRANSFER CHARACTERISTICS</b>					
Channel		2		4	Channels
Resolution			16		Bits
Conversion rate	LVDS, two- and three-channel mode	1		23.33	MHz/Ch
	LVDS, four-channel mode	1		17.5	MHz/Ch
	CMOS 8-bit × 2, two-channel mode	1		20	MHz/Ch
	CMOS 4-bit × 4, two-channel mode	1		10	MHz/Ch
	CMOS 8-bit × 2, three-channel mode	1		13.3	MHz/Ch
	CMOS 4-bit × 4, three-channel mode	1		6.7	MHz/Ch
	CMOS 8-bit × 2, four-channel mode	1		10	MHz/Ch
	CMOS 4-bit × 4, four-channel mode	1		5	MHz/Ch
Maximum differential nonlinearity		Gain = 1 V/V, 12-bit		±0.5	LSB
Maximum integral nonlinearity		Gain = 1 V/V, 12-bit		±2	LSB
No missing codes		Specified			
Signal-to-noise ratio	SNR	Gain = 1 V/V		72 <sup>(1)</sup>	dB
Analog channel crosstalk		Gain = 1 V/V, 12-bit, full-scale step		±15	LSB
Total absolute gain error		-10		10	%

(1) Specified by design.

**ELECTRICAL CHARACTERISTICS: VSP5612 (continued)**

All specifications at  $T_A = +25^\circ\text{C}$ , supply voltage = +3.3 V, conversion rate = 17.5 MHz, and four-channel mode, unless otherwise noted.

PARAMETER	TEST CONDITIONS	VSP5612			UNIT	
		MIN	TYP	MAX		
<b>ANALOG PROGRAMMABLE GAIN (APG)</b>						
Gain range	APG_x	0.5		3.5	V/V	
Gain step			63		Steps	
Gain relative error	Basis gain = 1 V/V	-10		10	%	
Gain monotonicity	Only APG_x	Specified				
<b>DIGITAL PROGRAMMABLE GAIN (DPG)</b>						
Gain range	DPG_x	1.0		2.0	V/V	
Gain step			255		Steps	
Gain monotonicity	Only DPG_x	Specified				
<b>AIN REFERENCE LEVEL (REF_AIN)</b>						
Internal DAC output	$V_{\text{RINT}}$	Setting code = 2		0.5	V	
		Setting code = 3		1.1	V	
		Setting code = 0 (default)		1.5	V	
		Setting code = 1		2.0	V	
Internal DAC output tolerance	$V_{\text{RINT}}$	-10		10	%	
Internal DAC output temperature drift	$V_{\text{RINT}}$	$T_A = 0^\circ\text{C}$ to $+85^\circ\text{C}^{(2)}$		-2	2	%
External reference range	$V_{\text{REXT}}$	0.5		$V_{\text{DD}} - 0.9$	V	
<b>INPUT CLAMP</b>						
Clamp level	$V_{\text{CLP}}$	Internal reference level clamp		$V_{\text{RINT}}$	V	
		External reference level clamp		$V_{\text{REXT}}$	V	
		Fixed level clamp		2.2	V	
Clamp-on resistance	$R_{\text{CLP}}$			500	$\Omega$	
<b>OFFSET DAC</b>						
Resolution			8		Bits	
Output range			$\pm 250$		mV	
Setting tolerance		-10		10	%	
Temperature drift		$T_A = 0^\circ\text{C}$ to $+85^\circ\text{C}^{(2)}$		-2	2	%

(2) Specified by design.

**THERMAL INFORMATION**

THERMAL METRIC <sup>(1)</sup>		VSP561xRSH	UNITS
		RSH	
		56 PINS	
$\theta_{\text{JA}}$	Junction-to-ambient thermal resistance	25.8	$^\circ\text{C}/\text{W}$
$\theta_{\text{JcTop}}$	Junction-to-case (top) thermal resistance	13.2	
$\theta_{\text{JB}}$	Junction-to-board thermal resistance	3.5	
$\psi_{\text{JT}}$	Junction-to-top characterization parameter	0.2	
$\psi_{\text{JB}}$	Junction-to-board characterization parameter	3.5	
$\theta_{\text{JcBot}}$	Junction-to-case (bottom) thermal resistance	0.4	

(1) For more information about traditional and new thermal metrics, see the *IC Package Thermal Metrics* application report, [SPRA953](#).

## PARAMETERIC MEASUREMENT INFORMATION

### Analog Input Specification (AIN1, AIN2, AIN3, AIN4)

The analog input specification has two signal inputs: negative and positive. These inputs are shown in [Figure 1a](#) and [Figure 1b](#), respectively.

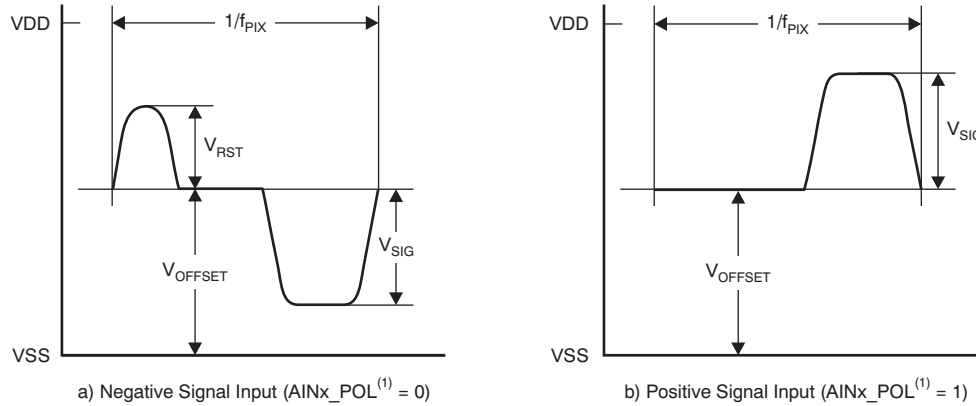

Figure 1. Analog Input Definition

Table 1. Timing Characteristics for [Figure 1](#)

PARAMETER	TEST CONDITIONS	MIN	TYP	MAX	UNIT
Input pixel rate	VSP5610	1		11.66	MHz/Ch
	VSP5611	1		16.66	MHz/Ch
	VSP5612	1		23.33	MHz/Ch
Signal range	Negative (AINx_POL <sup>(1)</sup> = 0)			V <sub>OFFSET</sub>	V
	Positive (AINx_POL <sup>(1)</sup> = 1)			VDD – V <sub>OFFSET</sub>	V
Maximum full-scale range	Gain = 0.5 V/V	1.8	2	2.2	V
Reset field through noise range		–V <sub>OFFSET</sub>	VDD – V <sub>OFFSET</sub>		V
Offset level	Fixed level clamp mode (REF_SEL = 0)		2.2		V
	Internal reference level clamp mode (REF_SEL = 1)		V <sub>RINT</sub>		V
	External reference level clamp mode (REF_SEL = 2)		V <sub>REXT</sub>		V

(1) AINx\_POL = Analog input polarity setting register (x = 1, 2, 3, and 4).

## LVDS Output Voltage Specification

The test load and voltage definition for the LVDS outputs are shown in [Figure 2](#).

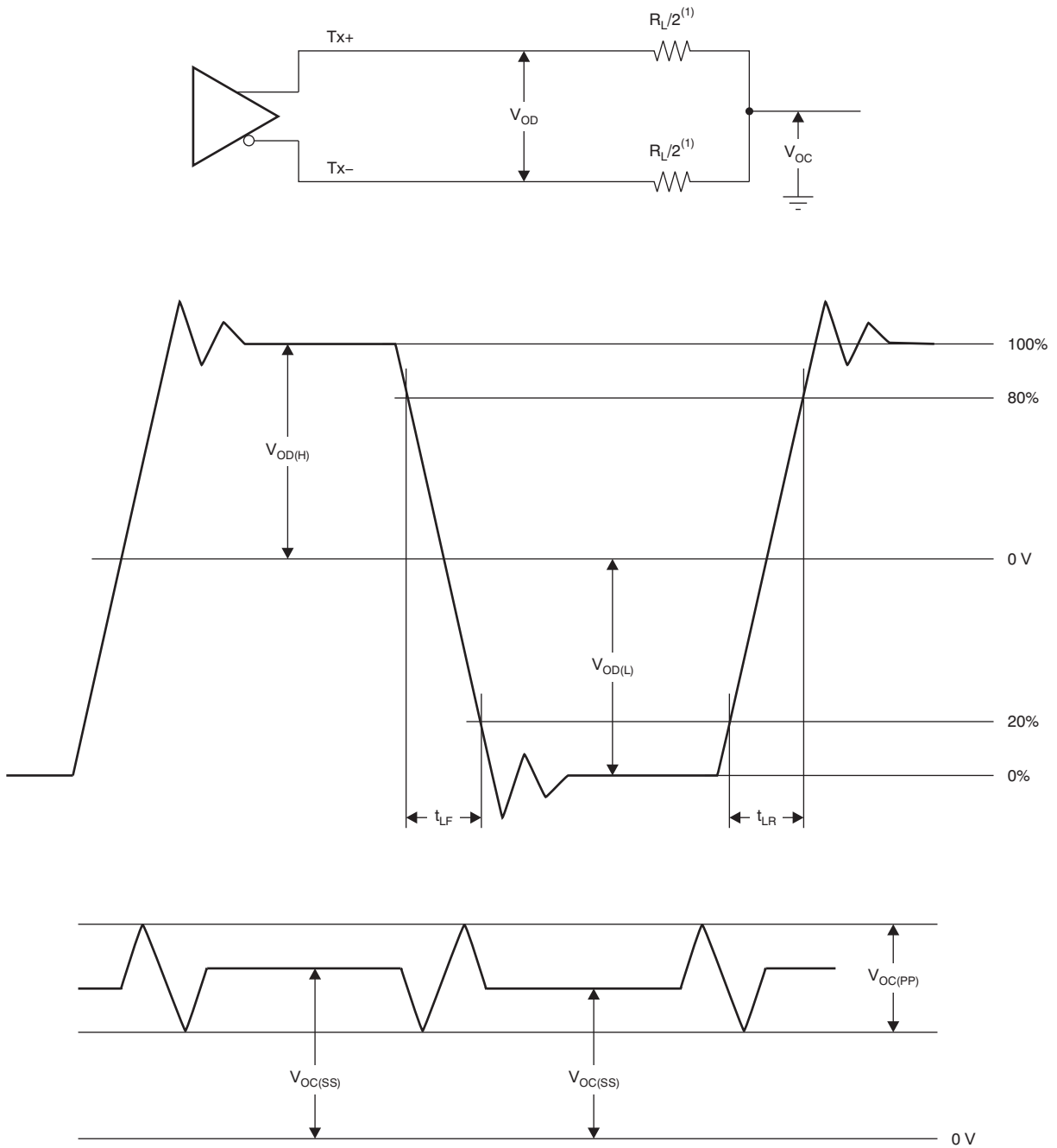

(1)  $R_L/2 = 49.9 \Omega \pm 1\%$

**Figure 2. Test Load and Voltage Definition for LVDS Outputs**

## PIN CONFIGURATION

### RSH PACKAGE QFN-56 (TOP VIEW)

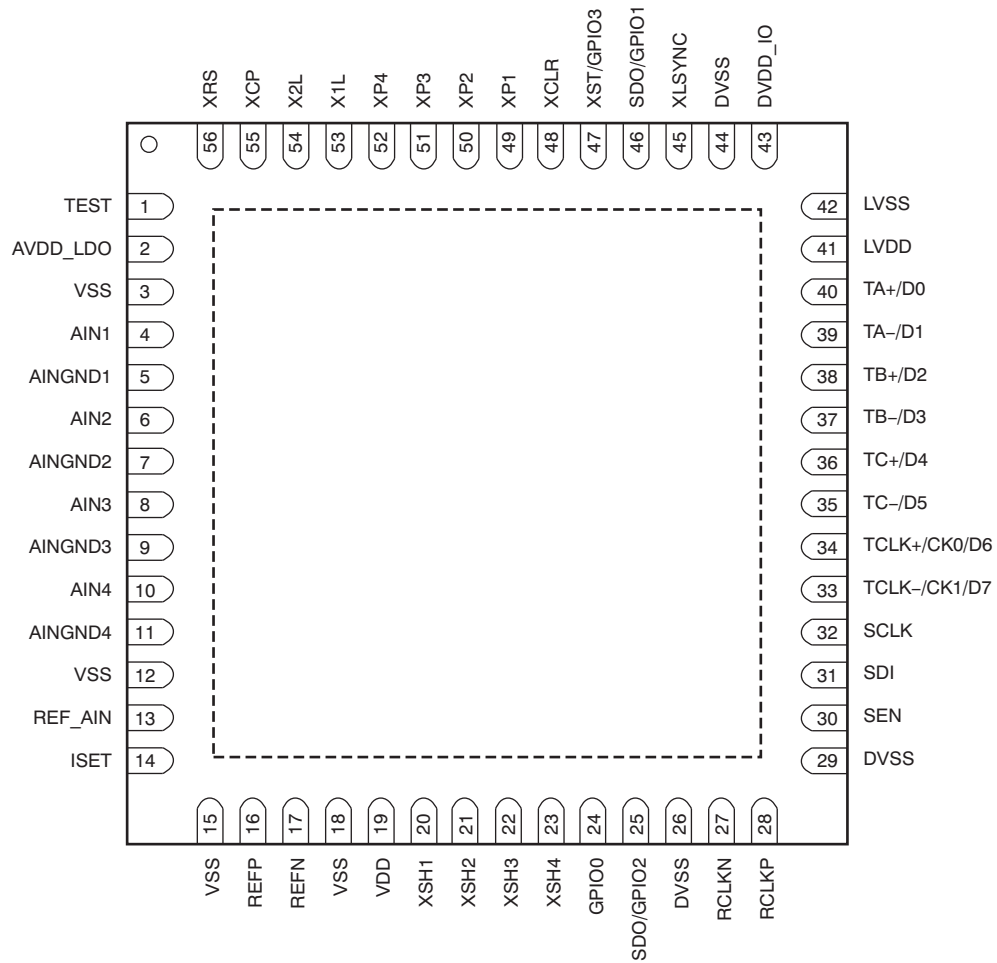

**PIN ASSIGNMENTS**

PIN NUMBER	PIN NAME	TYPE <sup>(1)</sup>	DESCRIPTION
1	TEST	DI3.3	Internal test pin; connect to DGND
2	AVDD_LDO	AP1.8	Analog core power voltage output; not connected, open
3	VSS	AGND	LDO and analog I/O ground
4	AIN1	AI3.3	First channel analog signal input <sup>(2)</sup>
5	AINGND1	AI3.3	First channel analog signal ground <sup>(2)</sup>
6	AIN2	AI3.3	Second channel analog signal input <sup>(2)</sup>
7	AINGND2	AI3.3	Second channel analog signal ground <sup>(2)</sup>
8	AIN3	AI3.3	Third channel analog signal input <sup>(2)</sup>
9	AINGND3	AI3.3	Third channel analog signal ground <sup>(2)</sup>
10	AIN4	AI3.3	Fourth channel analog signal input <sup>(2)</sup>
11	AINGND4	AI3.3	Fourth channel analog signal ground <sup>(2)</sup>
12	VSS	AGND	LDO and analog I/O ground
13	REF_AIN	AI3.3/AO3.3	REF_DAC_IN 0 = Analog signal reference output (default) 1 = Analog signal reference input
14	ISET	LVO1.8	Internal reference voltage output;bypass to ground with a 10-kΩ ±1% resistor
15	VSS	AGND	LDO and analog I/O ground
16	REFP	AO1.8	Positive reference; bypass to AGND with a 0.1-μF capacitor
17	REFN	AO1.8	Negative reference; bypass to AGND with a 0.1-μF capacitor
18	VSS	AGND	LDO and analog I/O ground
19	VDD	AP3.3	LDO and analog I/O power supply
20	XSH1	DO3.3	Sensor shift gate output 1
21	XSH2	DO3.3	Sensor shift gate output 2
22	XSH3	DO3.3	Sensor shift gate output 3
23	XSH4	DO3.3	Sensor shift gate output 4
24	GPIO0	DIO3.3	GPIO0_SEL 0 = GPIO0, general-purpose input port 0 (default) (In case of input, internal pull-down resistor) 1 = GPO0, general-purpose output port 0
25	SDO/GPIO2	DIO3.3	GPIO2_SDO_SEL 0 = GPIO2, general-purpose input port 2 (default) (In case of input, internal pull-down resistor) 1 = GPO2, general-purpose output port 2 2 = Reserved 3 = SDO, serial I/F data output
26	DVSS	DGND	Digital ground
27	RCLKN	LVI3.3	LVDS clock input
28	RCLKP	LVI3.3	CMOS master clock input/positive LVDS clock input
29	DVSS	DGND	Digital ground
30	SEN	DI3.3	Serial I/F enable; active low, internal pull-up resistor
31	SDI	DIO3.3	SDI_BUFF_CTRL 0 = Serial I/F data input 1 = Serial I/F data input/output (Internal pull-down resistor)
32	SCLK	DI3.3	Serial I/F clock (internal pull-down resistor)
33	TCLK-/CK1/ D7	LVO3.3	Negative LVDS clock output/Clock output 1/Data output bit 7
34	TCLK+/CK0/ D6	LVO3.3	Positive LVDS clock output/Clock output 0/Data output bit 6

- (1) AP3.3 = 3.3-V analog power supply; AP1.8 = 1.8-V analog power supply; AGND = analog ground; GND = ground; AO3.3 = 3.3-V analog output; AO1.8 = 1.8-V analog output; AI3.3 = 3.3-V analog input; DP3.3 = 3.3-V digital power supply; DP1.8 = 1.8-V digital power supply; DGND = digital ground; DO3.3 = 3.3-V digital output; DI3.3 = 3.3-V digital input; DIO3.3 = 3.3-V digital I/O; LVP3.3 = 3.3-V LVDS power supply; LVGND = LVDS ground; LVO3.3 = 3.3-V LVDS output; LVI3.3 = 3.3-V LVDS input; and LVO = 3.3-V LVDS output.
- (2) If these pins are unused, they can be opened or decoupled to GND with a decoupling capacitor.

**PIN ASSIGNMENTS (continued)**

PIN NUMBER	PIN NAME	TYPE <sup>(1)</sup>	DESCRIPTION
35	TC–/D5	LVO3.3	Negative TC channel LVDS data output/Data output bit 5
36	TC+/D4	LVO3.3	Positive TC channel LVDS data output/Data output bit 4
37	TB–/D3	LVO3.3	Negative TB channel LVDS data output/Data output bit 3
38	TB+/D2	LVO3.3	Positive TB channel LVDS data output/Data output bit 2
39	TA–/D1	LVO3.3	Negative TA channel LVDS data output/Data output bit 1
40	TA+/D0	LVO3.3	Positive TA channel LVDS data output/Data output bit 0
41	LVDD	LVP3.3	LVDS/CMOS output power supply
42	LVSS	LVGND	LVDS/CMOS output ground
43	DVDD_IO	DP3.3	Digital I/O power supply
44	DVSS	DGND	Digital ground
45	XLSYNC	DIO3.3	XLSYNC_SEL 0 = Internal line synchronous signal output (default) (In case of input, internal pull-down resistor) 1 = External line synchronous signal input. Polarity is set by the XLSYNC_POL register (default is active high).
46	SDO/GPIO1	DIO3.3	GPIO1_SDO_SEL 0 = GPI1, general-purpose input port 1 (default) (In case of input, internal pull-down resistor) 1 = GPO1, general-purpose output port 1 2 = Reserved, internal test input 3 = SDO, serial I/F data output
47	XST/GPIO3	DIO3.3	GPIO3_XST_SEL 0 = GPI3, general-purpose input port 3 (default) (In case of input, internal pull-down resistor) 1 = GPO3, general-purpose output port 3 2 = Reserved, internal test input 3 = XST, storage pulse output
48	XCLR	DO3.3	Sensor clear gate output
49	XP1	DO3.3	Fast transfer clock output $\phi$ 1
50	XP2	DO3.3	Fast transfer clock output $\phi$ 2
51	XP3	DO3.3	Fast transfer clock output $\phi$ 3
52	XP4	DO3.3	Fast transfer clock output $\phi$ 4
53	X1L	DO3.3	Fast transfer clock output 1L
54	X2L	DO3.3	Fast transfer clock output 2L
55	XCP	DO3.3	Clamp gate clock output
56	XRS	DO3.3	Reset gate clock output

FUNCTIONAL BLOCK DIAGRAM

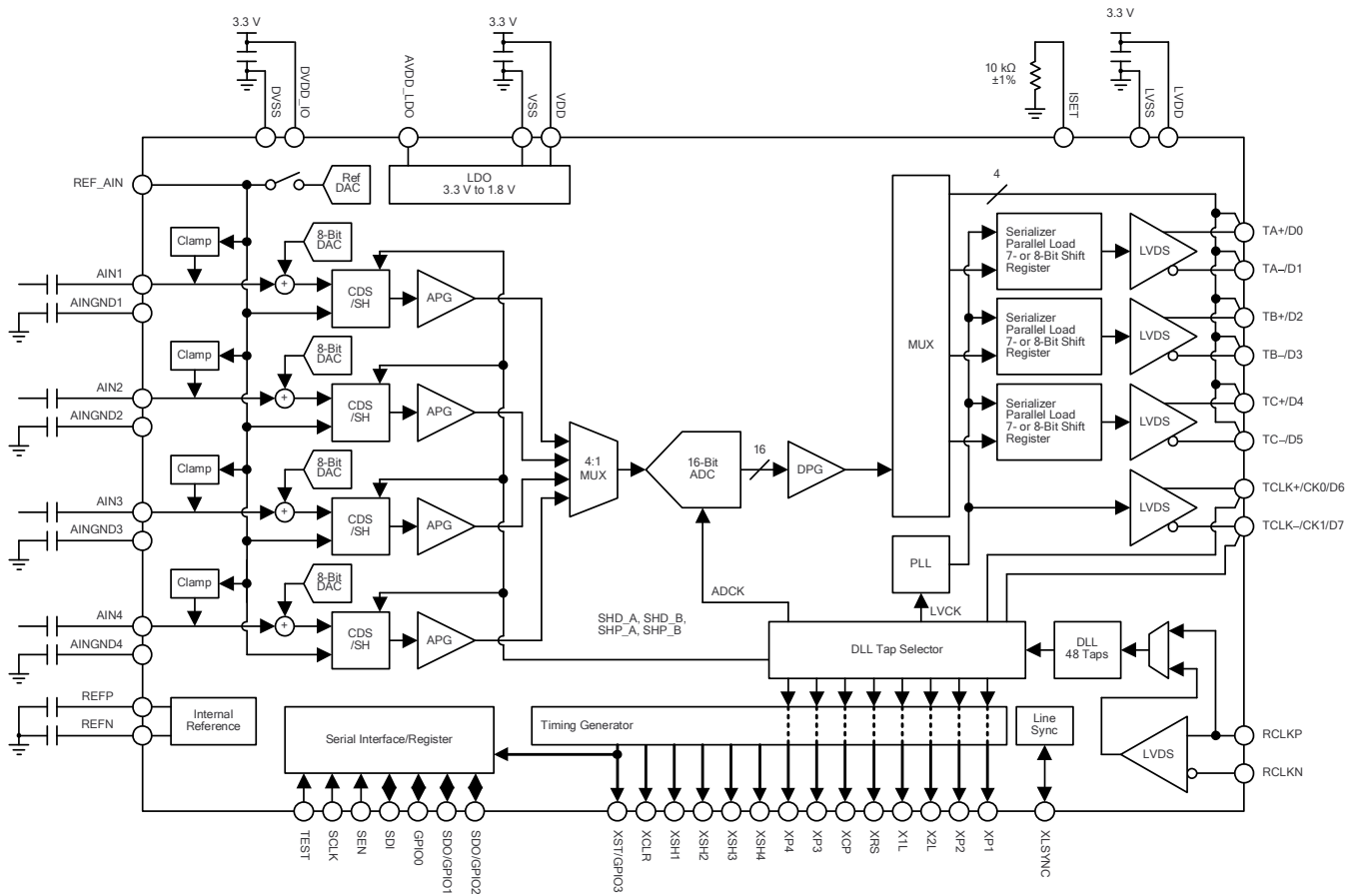

Figure 3. VSP5610/11/12 Block Diagram

## SYSTEM OVERVIEW

### INTRODUCTION

The VSP5610/11/12 are analog front-end (AFE) devices for CCD and CMOS line image sensor applications such as copiers, facsimile machines, etc. The VSP5610/11/12 each provide four independent data processing channels.

The data from each image sensor channel are sampled and held by either the SH or CDS circuit and are then converted into digital data by an ADC. The digital data for each channel are later converted into serial data that can be output in either LVDS mode or CMOS mode.

### AFE BLOCK

#### ANALOG SIGNAL INPUT

These devices have four channels that can be used as analog input ports for an image sensor. In addition to the four-channel input, this AFE device also supports three-channel and two-channel inputs. [Table 2](#) shows the register settings required to select the different channel modes.

**Table 2. Analog Input Channel Mode Selection**

MODE	AIN_CH_SEL	AIN1	AIN2	AIN3	AIN4
Two-channel	2	Active	Standby	Active	Standby
Three-channel	1	Active	Active	Active	Standby
Four-channel	0	Active	Active	Active	Active

Each analog input supports CDS and simple SH circuits to accommodate CCD and CMOS image sensors. The sampling mode can be selected independently for each channel by configuring the internal registers. As shown in [Table 3](#), if AINx\_SH\_CDS is set to '0', then the corresponding channel operates in CDS mode.

**Table 3. CDS/SH Mode Selection**

AINx_SH_CDS <sup>(1)</sup>	SH/CDS
0	CDS
1	SH

(1) AINx\_POL = Analog input polarity setting register (x = 1, 2, 3, and 4).

In addition, these devices also support independent selection of the input signal polarity for each channel. Input signal polarity can be set using the AINx\_POL register, where x = 1, 2, 3, or 4. The input signal range and polarity are defined in the [Analog Input Specification](#) section.

**Correlated Double Sampler (CDS) Mode (AINx\_SH\_CDS = 0)**

CDS mode is designed to accommodate inputs from the CCD sensor. The output signal of a CCD image sensor is sampled twice during one pixel period. First, the reference interval is sampled by the SHP pulse, then the data interval is sampled by the SHD pulse. Subtracting these two samples provides the video information of the pixel as well as removes any noise common to both intervals. Thus, CDS plays an important role in reducing the reset noise and other low-frequency noises that are present on the CCD output signal. Figure 4 shows a diagram of CDS mode.

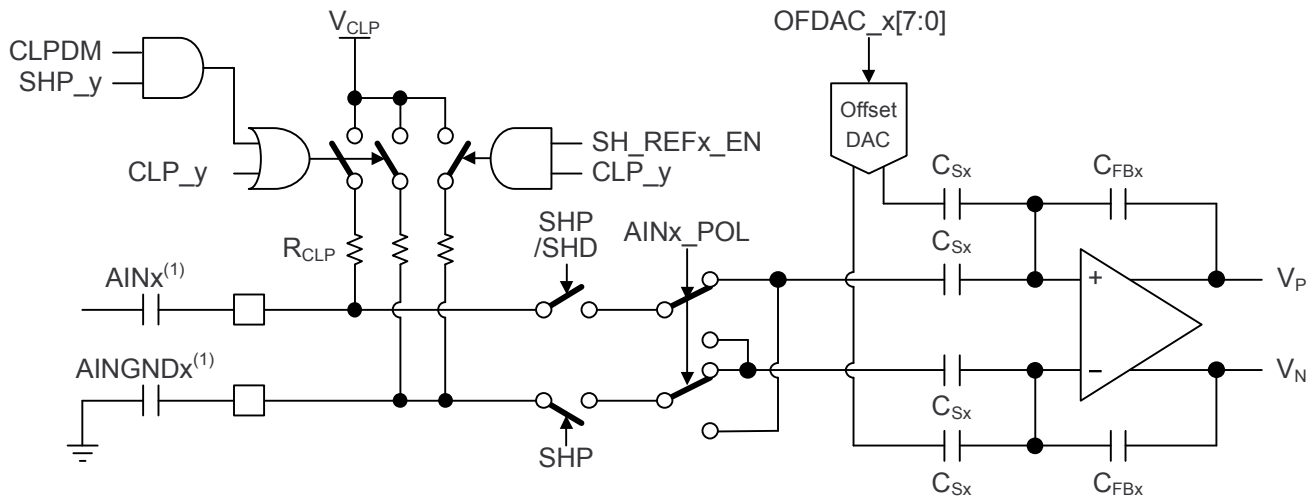
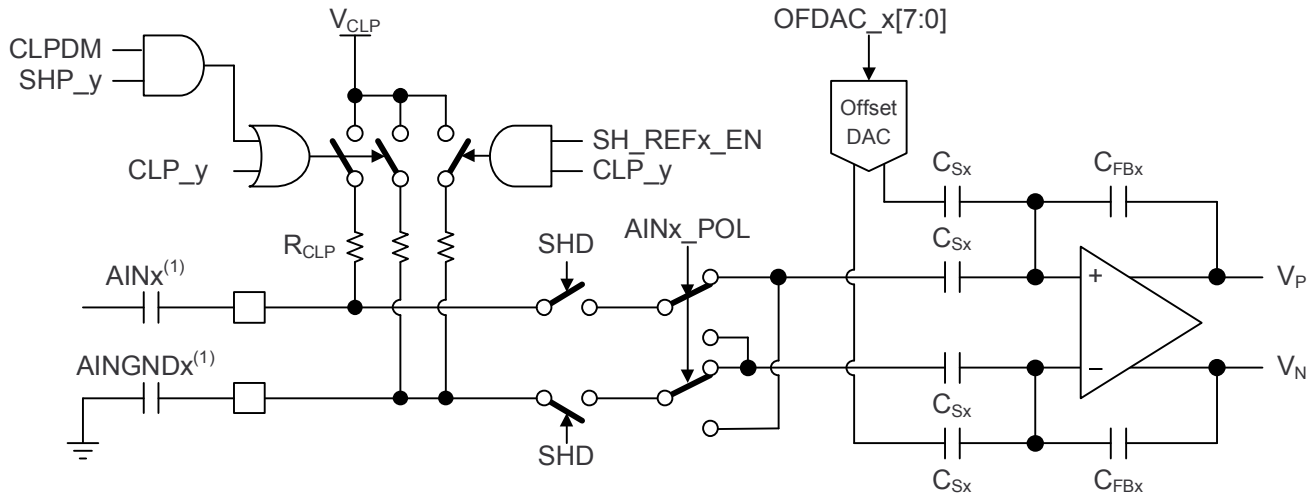

**Figure 4. CDS Mode Input Circuit for CCD Signal**

### Sample Hold (SH) Mode (AINx\_SH\_CDS = 1)

SH mode supports CCD and CMOS sensors. For the CCD sensor, the sensor signal pedestal level is clamped to the  $V_{CLP}$  level using an internal clamp circuit. SH samples only once during a pixel period. The SHD pulse is used to sample the CCD signal data interval. After sampling, the SH circuit takes the difference of the data and  $V_{CLP}$  levels to extract the video information.

For the CMOS input, the input clamp function should be set according to the requirements. If the sensor output is within the allowable input range, an ac-coupling capacitor for analog input may not be needed. When the sensor signal is directly input to the AFE, the SH circuit requires a reference voltage to set the black level. To use  $V_{CLP}$  as a reference, SH\_REFx\_EN should be enabled and AINGNDx then opened or coupled to GND with a capacitor. To use an external reference, it can be input to AINGNDx with sensor signals connected to AINx. Figure 5 shows a diagram of the SH mode.



- (1) Under some conditions, the sensor signal can be directly input to the AFE without requiring an external capacitor.  
(2) In SH mode, the SHP clock should be programmed so that it does not overlap the SHD clock.

Figure 5. SH Mode Input Circuit for CCD or CMOS Signal

### INPUT CLAMP AND SENSOR REFERENCE

The CCD output signal has a large dc offset that may exceed the input range of the AFE input circuit. Therefore, this output signal is ac-coupled to the AFE through a capacitor, and the internal dc level is set to the clamp voltage ( $V_{CLP}$ ) by an internal clamp circuit. The VSP5610/11/12 provide three modes for clamp operation: pixel clamp, line clamp, and not clamped. These modes are shown in Table 4. The clamp mode can be set independently for each channel by configuring the AINx\_CLP\_SEL register.

Table 4. Clamp Mode Selection

CLAMP MODE	MODE SETTING	CLAMP ACTIVE CONDITION AND SETTING			
	AINx_CLP_SEL <sup>(1)</sup>	CDS/SH	CLP_y <sup>(2)</sup>	CLPDM AND SHP_y <sup>(2)</sup>	SH_REF_EN
Pixel clamp	0 (default)	CDS/SH	Active	Active	Off
Line clamp	1	CDS/SH	—	Active	Off
Not clamped	2	Only SH	—	—	On
	3	Only SH	—	—	Off

- (1) AINx\_CLP\_SEL (x = 1, 2, 3, and 4).  
(2) y = A and B.

In pixel clamp mode, CLP\_A/B is used for clamping. The input signal is clamped to  $V_{CLP}$  via the CLP\_A/B pulse during each pixel period, as shown in Figure 6a. Because the ac-coupling capacitor is charged on a pixel-to-pixel basis, the clamp level droop can be controlled by the clamp pulse width.

In line clamp mode, SHP\_A/B is used for clamping when CLPDM is active, as shown in Figure 6b. The input signal is clamped only in the CLPDM period within one line cycle of the sensor. The signal is clamped in this method because the charge leaks the least from the coupling capacitor during the CLPDM period. Accordingly, because there may be a large droop in the clamp level, this device does not support line clamp in the SH mode.

The *not-clamped* mode is mainly used in for a CMOS sensor input. If the sensor signal is directly connected to the AFE, this mode should be configured without an ac-coupling capacitor at the input port. This mode has two options to select a reference for the sensor black level: internal reference and external input. In the internal reference option, the internal reference ( $V_{CLP}$ ) is used with  $AINx\_CLP\_SEL = 2$ . In the external input option, the external input is used from  $AINx\_CLP\_SEL = 3$ .

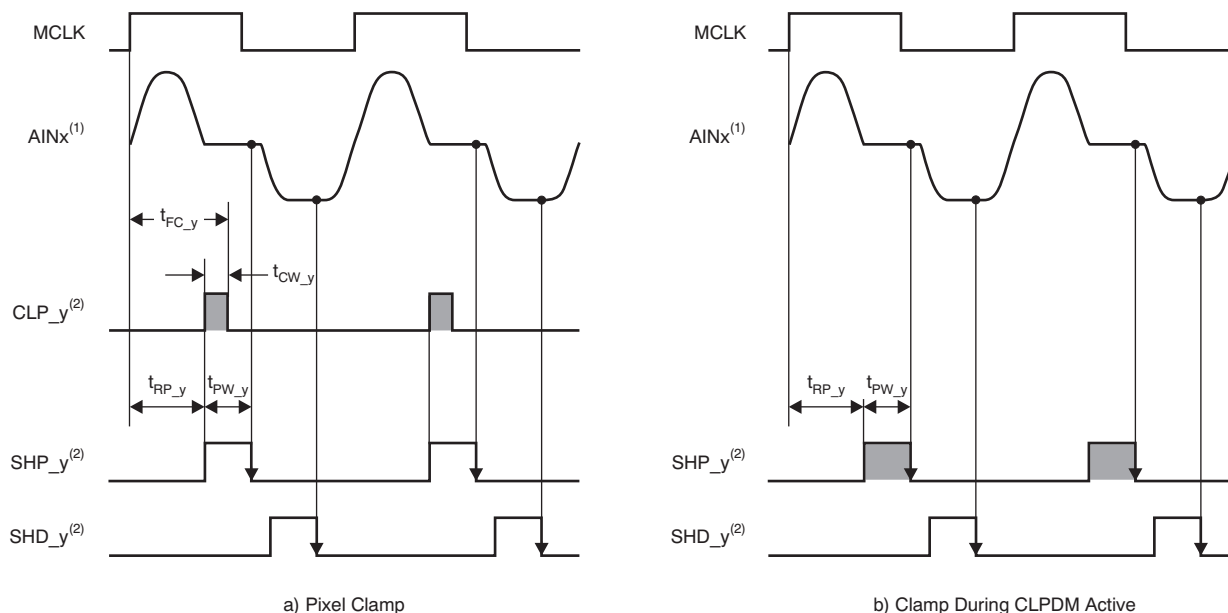

(1) x = AIN channel number, x = 1, 2, 3, and 4.

(2) y = Group code of sample pulse signals. When x = 1 or 2, y = A. When x = 3 or 4, y = B.

**Figure 6. Input Clamp Function**

As shown in Figure 7, the internal  $V_{CLP}$  node provides the clamp reference voltage. As for the clamp level, it is possible to select three reference voltage modes by setting the  $AINx\_REF\_SEL$  register. The first mode provides a fixed 2.2 V, the second mode provides selectable outputs (0.5 V, 1.1 V, 1.5 V, and 2.0 V) of an internal DAC, and the third mode allows an external input from the  $REF\_AIN$  pin to be used as the clamp reference. This  $REF\_AIN$  pin is bidirectional and also acts as an output of the internal DAC. Table 5 shows the relationship between the register and clamp level. Table 6 shows the DAC configuration.

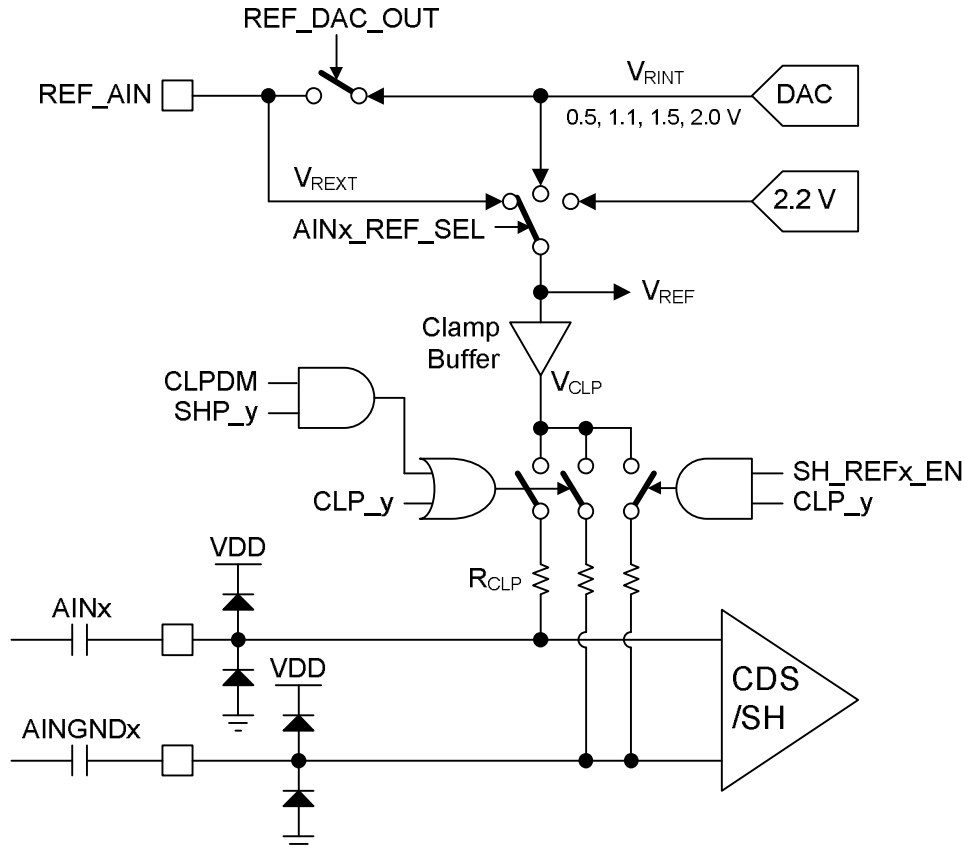

(1) If the sensor signal is directly input to the AFE, the external capacitor should not be connected.

Figure 7.  $V_{CLP}$  Block Diagram

Table 5. Clamp Level Selection

MODE SETTING $AINx\_REF\_SEL[1:0]$ <sup>(1)</sup>	CLAMP LEVEL	
0	2.2 V	
1	$V_{RINT}$	Reference DAC (0.5 V, 1.1 V, 1.5 V, and 2.0 V)
2	$V_{REXT}$	$REF\_AIN$ external input

(1)  $AINx\_CLP\_SEL$  ( $x = 1, 2, 3,$  and  $4$ ).

Table 6.  $V_{RINT}$  Voltage Selection

SETTING CODE	$V_{RINT\_SEL}$	REF DAC $V_{RINT}$ (V)
2		0.5
3		1.1
0		1.5 (default)
1		2.0

If line clamp mode is used, the CLPDM period should be configured by the internal registers. The CLPDM period is determined with reference to the line cycle signal for the sensor (LS). Thus, the start and end of CLPDM are each defined as the number of pixels from the LS falling edge. Because CLPDM is used as the clamp period, it should be assigned for the interval of any dummy or optical black pixels. Figure 8 shows the relationship between LS and CLPDM.

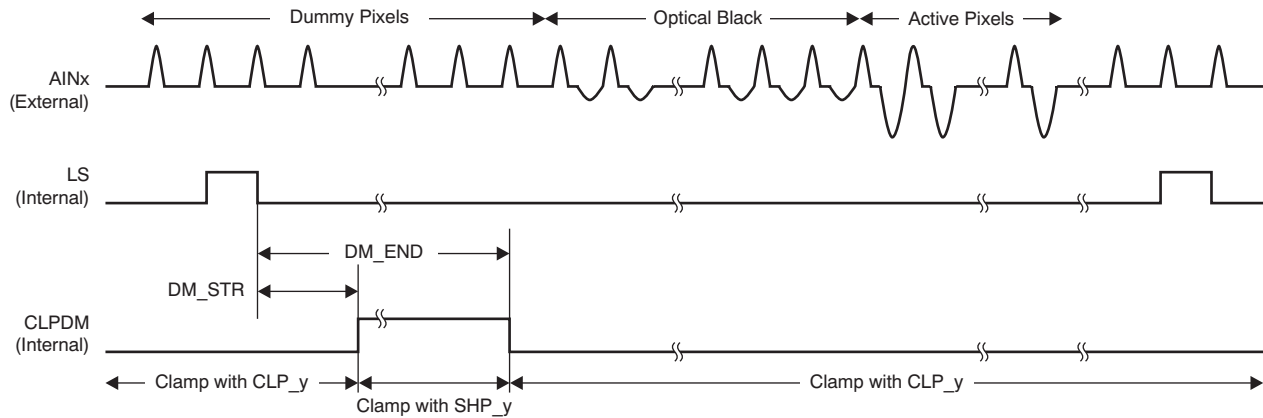

Figure 8. Line Clamp Period Setting

### Pixel Clamp Period Setting

In pixel clamp mode, without CLPDM, the sensor signal is clamped with CLP\_A and CLP\_B pulses. CLP\_A corresponds to AIN1 and AIN2; CLP\_B corresponds to AIN3 and AIN4. The start of these pulses is synchronized with the SHP\_y rising edge (where y = A or B). There are two options to configure the end position: first, to automatically set the pulse width to 50% that of SHP\_y; and second, to manually configure the end position using an internal register. Figure 9 and Figure 10 illustrate the details of the clamp pulse function in automatic and manual modes, respectively.

#### Automatic Mode (CLP\_TF\_AT\_DIS = 0)

Figure 9 shows the automatic mode when CLP\_TF\_AT\_DIS is '0'.

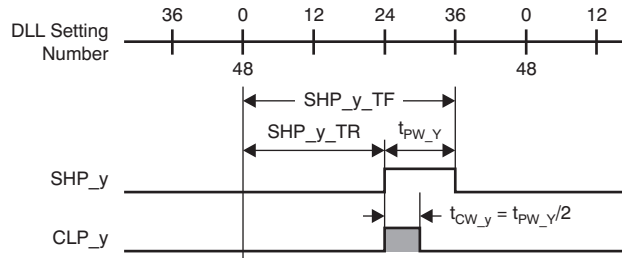

Figure 9. Automatic Mode

#### Manual Mode (CLP\_TF\_AT\_DIS = 1)

Figure 10 shows the manual mode when CLP\_TF\_AT\_DIS is '1'.

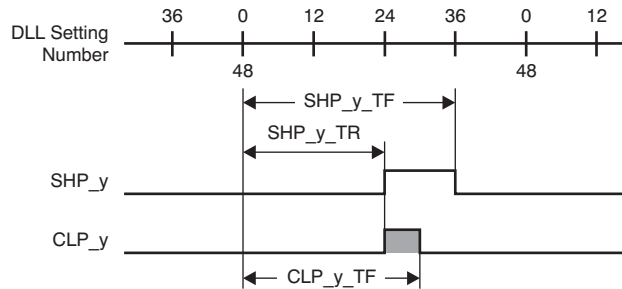
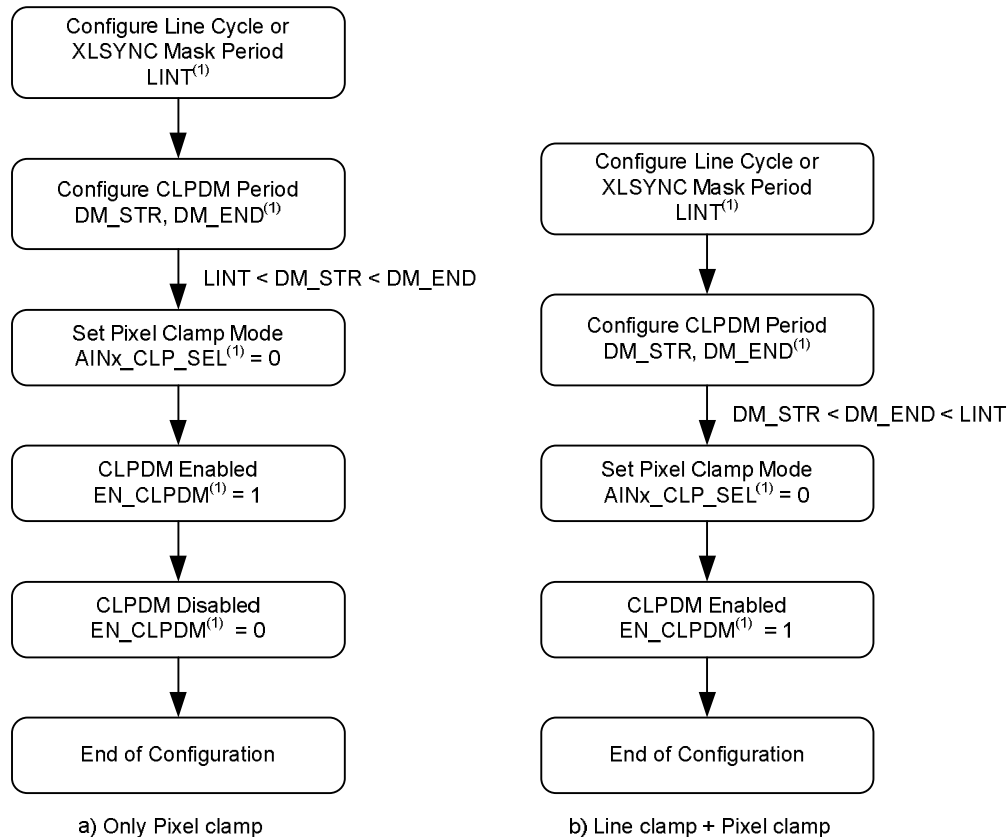

Figure 10. Manual Mode

In pixel clamp mode when CLPDM is active, the sensor signal is clamped with SHP\_y. Therefore, the pixel clamp operation is closely related with the status of CLPDM. The condition of CLPDM should be properly defined with the internal registers. Because CLPDM is always high during a default condition after reset or power up, the status of CLPDM should be defined according to this sequence. Furthermore, the CLPDM status should be defined in the second step of the flowchart shown in Figure 11 for either configuration. All other user-dependent settings, except XLSYNC\_SEL and EN\_OUT of the software reset sequence, are described in Figure 11.



(1) Internal registers: AINx\_CLP\_SEL = addresses 16 and 17; LINT = address 7; DM\_STR = address 8; DM\_END = address 9; and EN\_CLPDM = address 399, bit 1.

Figure 11. Configuration Sequence for Pixel Clamp

## ANALOG PROGRAMMABLE GAIN (APG)

The SH output can be amplified using programmable analog gain. This gain can be set from 0.5 V/V to 3.5 V/V with a step size of 3/64 V/V.

The gain setting can be controlled by an internal register (APG\_x). Equation 1 shows the relationship between the setting code and gain. The gain of each of the four channels can be set independently using different registers. Note that the black pixel level may possibly change as a result of the change in the gain; therefore, the appropriate timing of the gain change should be used to avoid degradation in image quality. Figure 12 shows analog gain as a function of gain control code in terms of V/V. Figure 13 shows the maximum allowed input signal as a function of gain control code.

$$\text{APG (V/V)} = \frac{3}{63} \times \text{Code} + 0.5 \quad (\text{Code} = 0 \text{ LSB to } 63 \text{ LSB}) \quad (1)$$

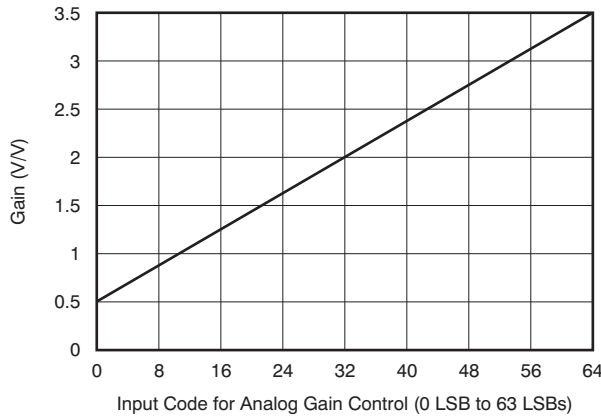

Figure 12. Analog Gain vs Setting Code

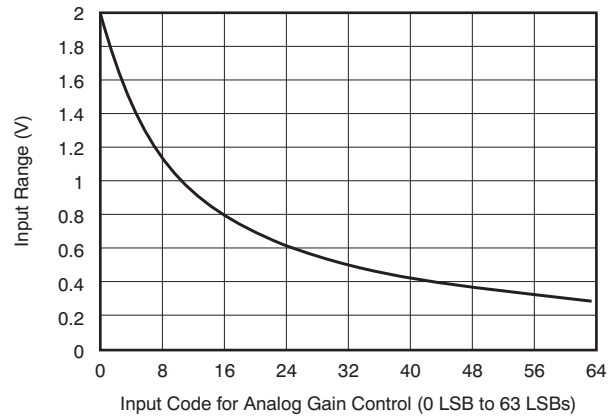

Figure 13. Input Range vs Analog Gain Setting Code

## DIGITAL PROGRAMMABLE GAIN (DPG)

The VSP5610/11/12 provide a maximum digital gain of 2 V/V. The total gain is fixed by the combination of CDS/SH analog gain (APG) and digital gain (DPG). DPG is controlled by an 8-bit internal register (DPG\_x) that can set the gain from 1 V/V to 2 V/V, as defined by Equation 2. This register is included in each of the four channels, so the gain of each channel can be set independently.

Figure 14 shows the relationship between the digital gain and register code. Note that the default value is 1 V/V.

$$\text{DPG (V/V)} = \frac{1}{256} \times \text{Code} + 1 \quad (\text{Code} = 0 \text{ LSB to } 255 \text{ LSB}) \quad (2)$$

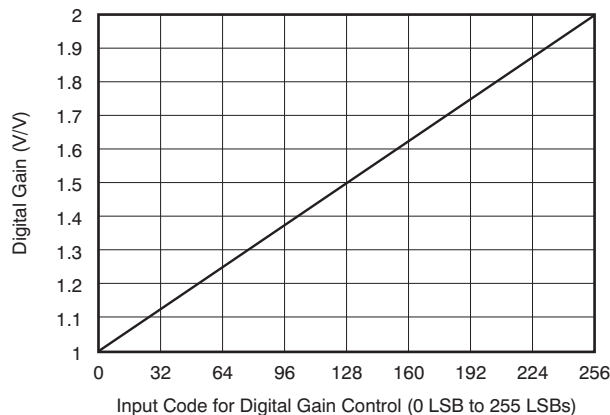

Figure 14. Digital Gain Setting Code

## ADC

The ADC output format is selectable as twos complement or offset binary by configuring a register. [Table 7](#) shows the relationship between register setting and condition.

**Table 7. ADC Data Format Configuration**

ADC_DAT_FRM	MODE
0 (default)	Twos complement
1	Offset binary

## OFFSET DAC

The VSP5610/11/12 have an independent DAC in each channel for offset level correction of the input signal. The correction range is  $\pm 250$  mV and resolution is 8 bits. The DAC output voltage can be set by register settings. [Table 8](#) and [Figure 15](#) show the relationship between the output and setting codes. The setting code is defined in twos complement format. The DAC output offset voltage in millivolts as a function of the register setting is given in [Equation 3](#).

**Table 8. Offset DAC Setting Code**

SETTING CODE OFDAC_x[7:0] <sup>(1)</sup>	OUTPUT (mV)
7Fh	248.05
7Eh	246.09
...	...
01h	1.95
00h	0
FFh	-1.95
...	...
81h	-248.05
80h	-250.00

(1) x = 1, 2, 3, and 4.

$$\text{DAC Output (mV)} = \frac{250}{128} \times \text{OFDAC}_x[7:0]$$

where:

$$x = 1, 2, 3, \text{ and } 4$$

(3)

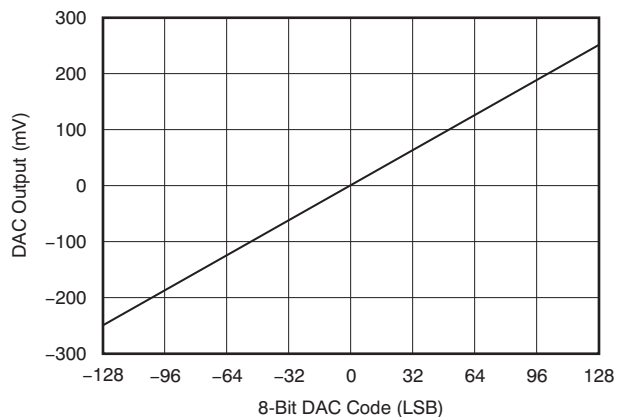

**Figure 15. Offset DAC Setting Code vs Output Voltage**

## TIMING GENERATOR (TG)

The image sensor timing generator (TG) is incorporated into these devices. The TG provides six signals that function as slow transfer clocks and eight signals that function as fast transfer clocks. In addition, the fast clock signals can also be used as slow clock signals. The TG signals are synchronized with LS (which is the image sensor line cycle) and are completely controlled by the internal registers. Because the TG output is locked under the default setting, EN\_OUT (address 2, bit 10) should be set to '1' to enable the outputs.

### LINE SYNCHRONOUS FUNCTION

The VSP5610/11/12 have two modes for synchronizing the sensor line cycle: internal line (Figure 16) and external line synchronous mode (Figure 17). In internal line synchronous mode, the line cycle signal (LS) is generated after a certain number of MCLK cycles that are counted by an internal counter (PIX\_CNT). The number of MCLK cycles is determined by the LINT[19:0] register; the counter clears after LS is generated. The active LS period is equal to one MCLK cycle period.

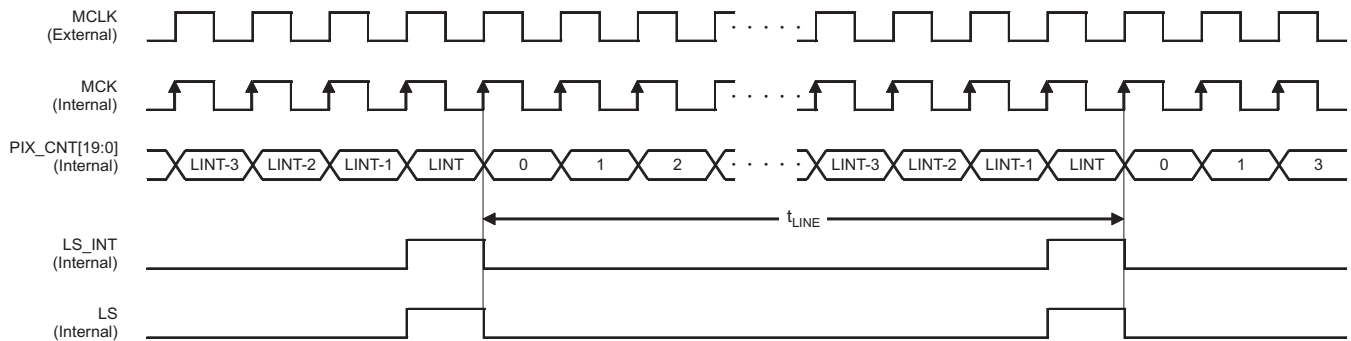

Figure 16. Internal Line Synchronous Mode (XLSYNC\_SEL = 1)

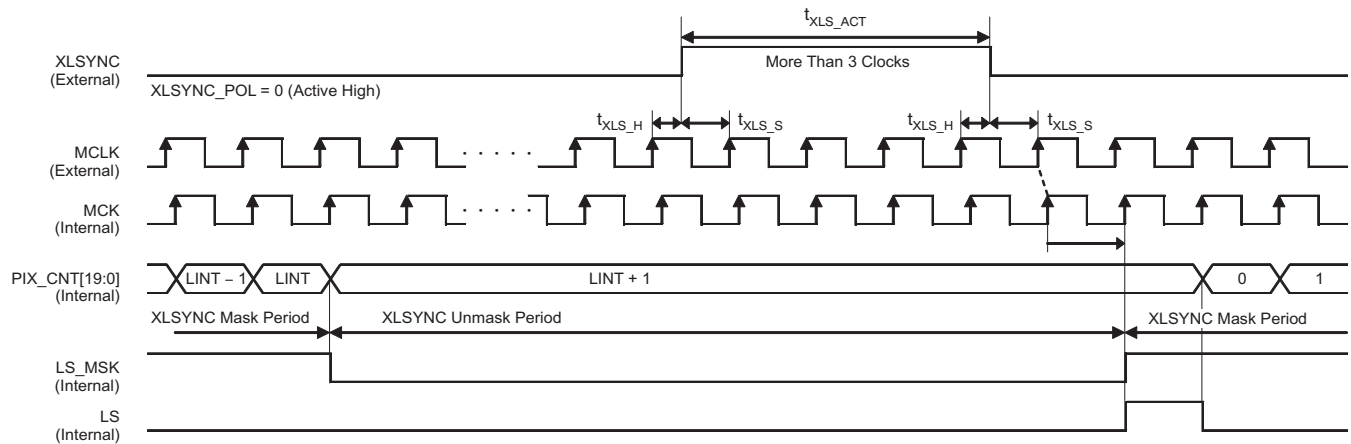

Figure 17. External Line Synchronous Mode (XLSYNC\_SEL = 0, default)

Table 9. Timing Requirements for Figure 16 and Figure 17

PARAMETER	TEST CONDITION	MIN	TYP	MAX	UNIT
t <sub>LINE</sub>	Line cycle period setting	3	LINT + 1	2 <sup>20</sup> - 1	Clocks
t <sub>XLS_ACT</sub>	XLSYNC active period	3			Clocks
t <sub>XLS_S</sub>	XLSYNC setup to MCLK	10			ns
t <sub>XLS_H</sub>	XLSYNC hold to MCLK	10			ns

The other mode is the external line synchronous mode which requires an external signal (XLSYNC). In this mode, if the logic circuit detects an active XLSYNC period for more than three MCLK cycles, the internal line synchronous signal (LS) is generated. This mode has a function that mask XLSYNC in order to avoid noise interference. The duration of the XLSYNC mask can be set by the LINT[19:0] register, which is also used in the internal line synchronous mode.

The two line synchronous modes and the polarity can be selected by the XLSYNC\_SEL and XLSYNC\_POL registers, respectively. The default settings are external mode and active high polarity. XLSYNC can be used to output some internal signals. Table 10 shows the register settings required to select the desired output signals.

PIX\_CNT can be automatically reset by LS\_CNT\_RST (which is an internal register). Before performing this function, a software reset must be executed in order set RST\_ALL to '1'. If LS\_CNT\_RST is set to '1' after a software reset, the pixel counter is then held at '0'. To make the counter active, LS\_CNT\_RST should return to '0'.

**Table 10. XLSYNC Output Signal (XLSYNC\_SEL = 1)**

REGISTER SETTING XLSYNC_OUT	OUTPUT SIGNAL
0	LS
1	CLPDM
2	Reserved
3	Reserved

### SLOW TRANSFER CLOCK SETTING (XST, XSHn, XCLR)

XST, XSHn (where n = 1 to 4), and XCLR are slow transfer clocks that can be configured by setting the initial polarity and toggle points. As shown in Table 11, the predetermined number of toggle points is different for each signal. Because the two toggles generate one pulse, the number of pulses is half the number of toggles.

**Table 11. Toggle Number and Generated Pulse**

SIGNAL	TOGGLE	PULSE
XST	8	4
XSHn	16	8
XCLR	48	24

Each toggle position is defined by a register that is exclusive for each signal. The toggle position is synchronized with LS and the gap between the toggle position and the LS falling edge. The LS falling edge is defined in terms of  $t_{MCLK}$ , the cycle period of MCLK. This gap is set by register settings and is defined by Equation 4:

$$t = (Xn\_T(k) + 1) \times t_{MCLK}$$

where:

$n = ST, SHn, CLR$

$k = 0$  to 7 (XST);  $k = 0$  to 15 (XSHn);  $k = 0$  to 47 (XCLR)

$Xn\_T(k)$  is less than LINT and is the register value of the toggle setting (4)

The toggle for each signal can be disabled with register settings. To make the toggle active,  $Xn\_TGL\_EN$  should be set to '1'. However, because XST shares a pin with GPIO3, pin function should be configured with the GPIO3\_XST\_SEL register. Figure 18 shows the configuration regarding the slow transfer clock.

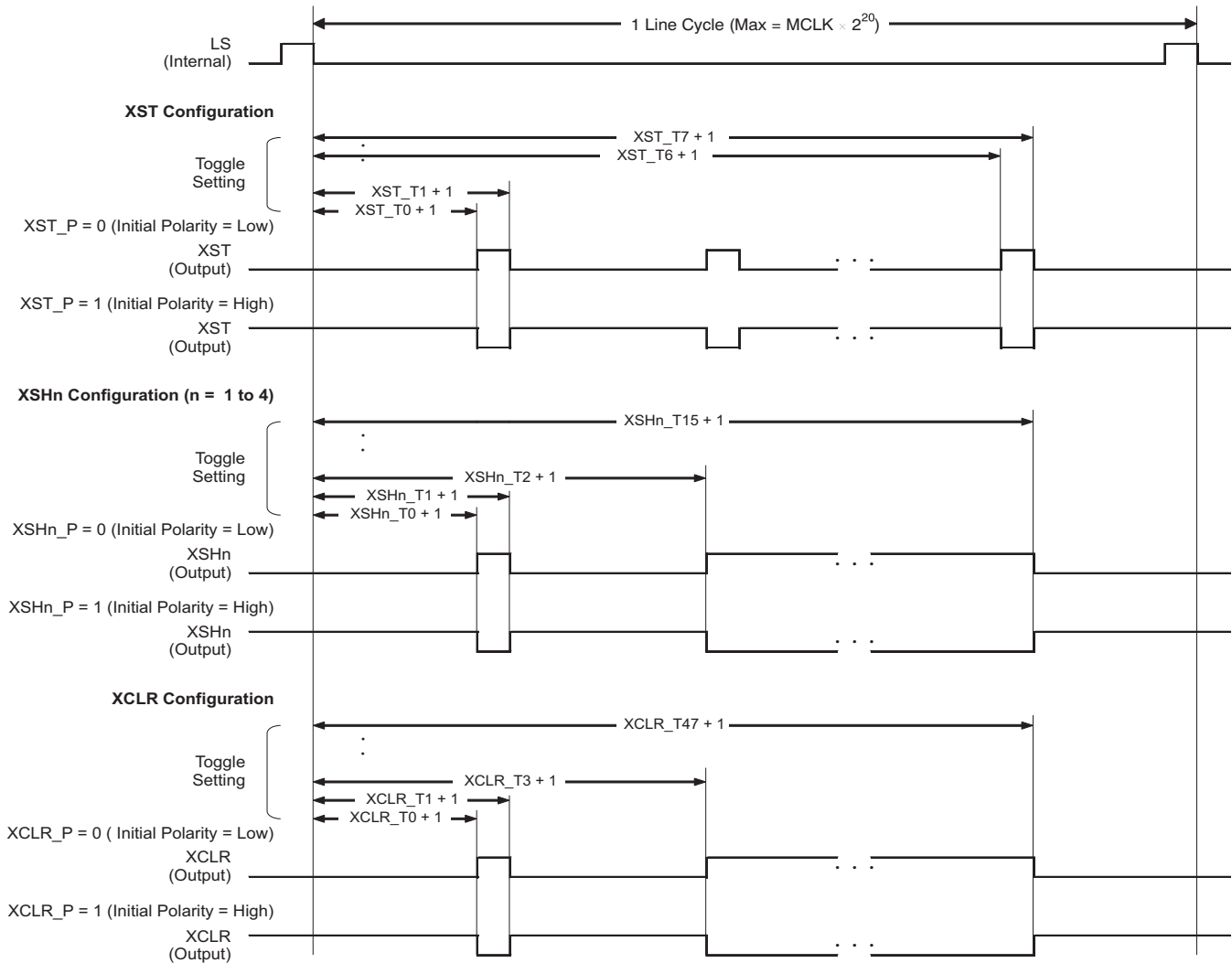

- (1) If  $Xn\_Tn$  is set to '0', the toggle position is ignored (except for  $Xn\_T0$ ).
- (2) The period between the toggle position and LS falling edge =  $(Xn\_T(k) + 1) \times t_{MCLK}$ .
- (3) The following requirement must be satisfied:  $Xn\_T(k) < Xn\_T(k + 1)$ .
- (4) The signal is set to the desired polarity settings at the falling edge of LS.

Figure 18. Slow Transfer Gate Signal Setting for XST, XSHn, and XCLR

## FAST TRANSFER CLOCK PULSE SETTING

XP1/2, X1L, X2L, XRS, XCP, and XP3/4 are fast transfer clock signals with rising and falling edges that are configurable via register settings. Figure 19 shows the block diagram of the fast clock configuration. In Figure 19, the *DLL Tap Selector* is used to select both the rising and the falling edges of each signal from among 48 tap positions.

The XP2 clock signal is an inverse of XP1 and shares rising and falling edge settings. Similarly, XP4 is an inverse of XP3 and likewise shares rising and falling edge settings. The other signals have individual configuration registers for setting the position of both edges.

In addition, it is possible to change the clock rate of each signal with register settings. The clock rate is based on the frequency of MCLK. XP1 and XP2 can select x1, x2, or x4 modes with common settings. XP3 and XP4 can also select x1, x2, or x4 modes with common settings. The other signals can choose between the x1 and x2 rate settings.

Note that two independent sets of registers are available to set the clock rate, the clock rising edge, and the clock falling edge for operation in x1-mode and x2-mode.

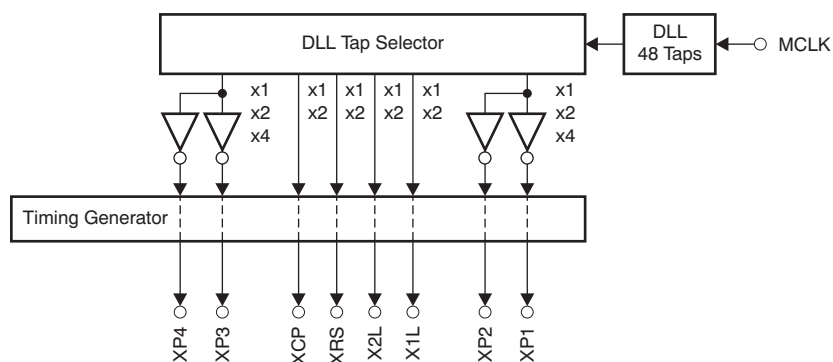

Figure 19. Fast Transfer Clock Pulse Generator

### Fast Transfer Clock Pulse Timing

This section describes the timing of the fast transfer clock pulse for XRS (Figure 20), XCP (Figure 21), XP1 and XP2 (Figure 22), XP3 and XP4 (Figure 23), and X1L and X2L (Figure 24).

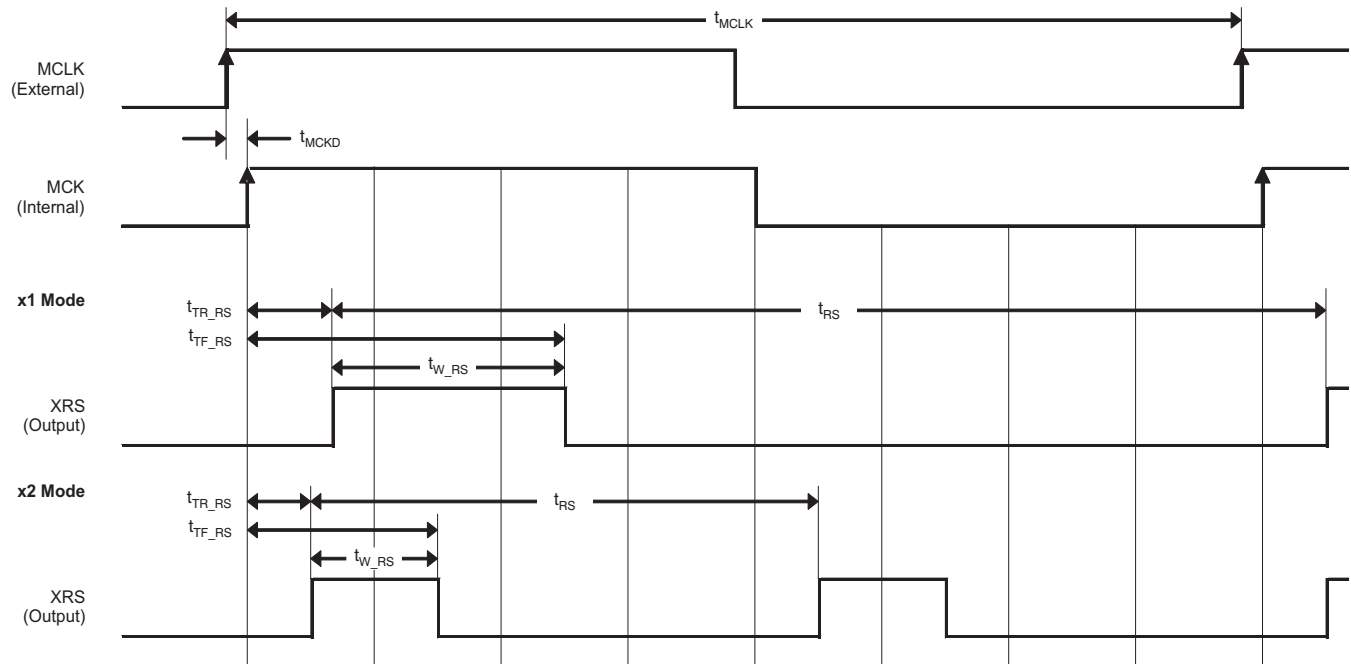

Figure 20. XRS Fast Transfer Clock Pulse Setting

Table 12. Timing Requirements for Figure 20

PARAMETER	TEST CONDITIONS	MIN	TYP	MAX	UNIT
$f_{MCLK}$	MCLK frequency	VSP5610	1	11.66	MHz
		VSP5611	1	16.66	MHz
		VSP5612	1	23.33	MHz
$t_{MCLK}$	MCLK period		$1/f_{MCLK}$		ns
$t_{MCKD}$	MCLK to MCK delay		2		ns
$t_{RS}$	XRS period	x1 mode		$t_{MCLK}$	ns
		x2 mode		$t_{MCLK} \times 1/2$	ns
$t_{TR\_RS}$	XRS rising edge delay from MCK	x1 mode	0	$t_{MCLK} \times 47/48$	ns
		x2 mode	0	$t_{MCLK} \times 23/24$	ns
$t_{TF\_RS}$	XRS falling edge delay from MCK	x1 mode	0	$t_{MCLK} \times 47/48$	ns
		x2 mode	0	$t_{MCLK} \times 23/24$	ns
$t_{W\_RS}$	XRS pulse width	x1 mode	2	$t_{MCLK} - 2$	ns
		x2 mode	2	$t_{MCLK} \times 1/2 - 2$	ns

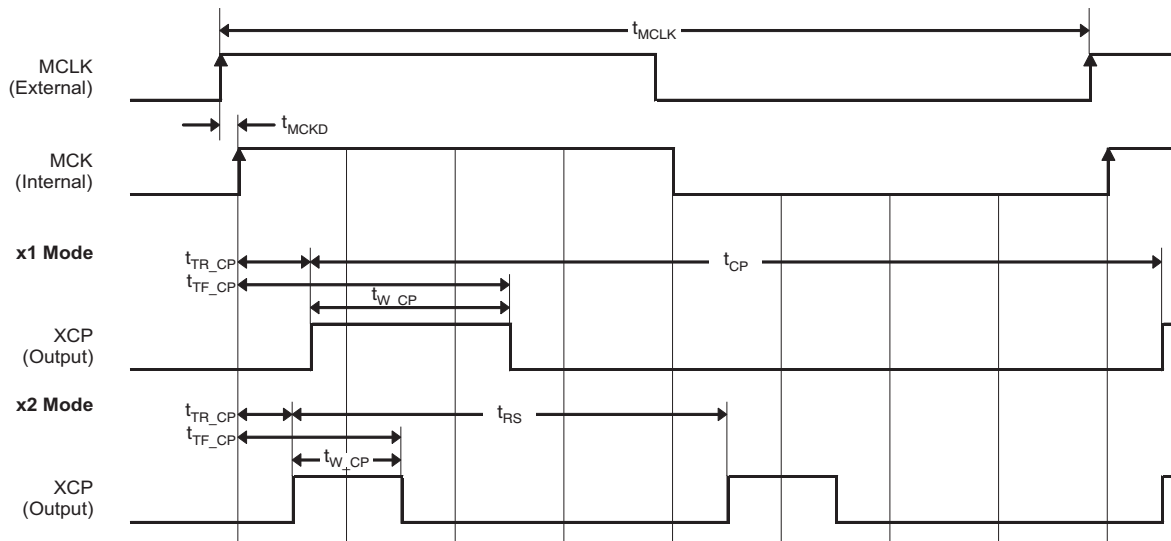

Figure 21. XCP Fast Transfer Clock Pulse Setting

Table 13. Timing Requirements for Figure 21

PARAMETER	TEST CONDITIONS	MIN	TYP	MAX	UNIT
$f_{MCLK}$	MCLK frequency	VSP5610	1	11.66	MHz
		VSP5611	1	16.66	MHz
		VSP5612	1	23.33	MHz
$t_{MCLK}$	MCLK period		$1/f_{MCLK}$		ns
$t_{MCKD}$	MCLK to MCK delay		2		ns
$t_{CP}$	XCP period	x1 mode	$t_{MCLK}$		ns
		x2 mode	$t_{MCLK} \times 1/2$		ns
$t_{TR\_CP}$	XCP rising edge delay from MCK	x1 mode	0	$t_{MCLK} \times 47/48$	ns
		x2 mode	0	$t_{MCLK} \times 23/24$	ns
$t_{TF\_CP}$	XCP falling edge delay from MCK	x1 mode	0	$t_{MCLK} \times 47/48$	ns
		x2 mode	0	$t_{MCLK} \times 23/24$	ns
$t_{W\_CP}$	XCP pulse width	x1 mode	2	$t_{MCLK} - 2$	ns
		x2 mode	2	$t_{MCLK} \times 1/2 - 2$	ns

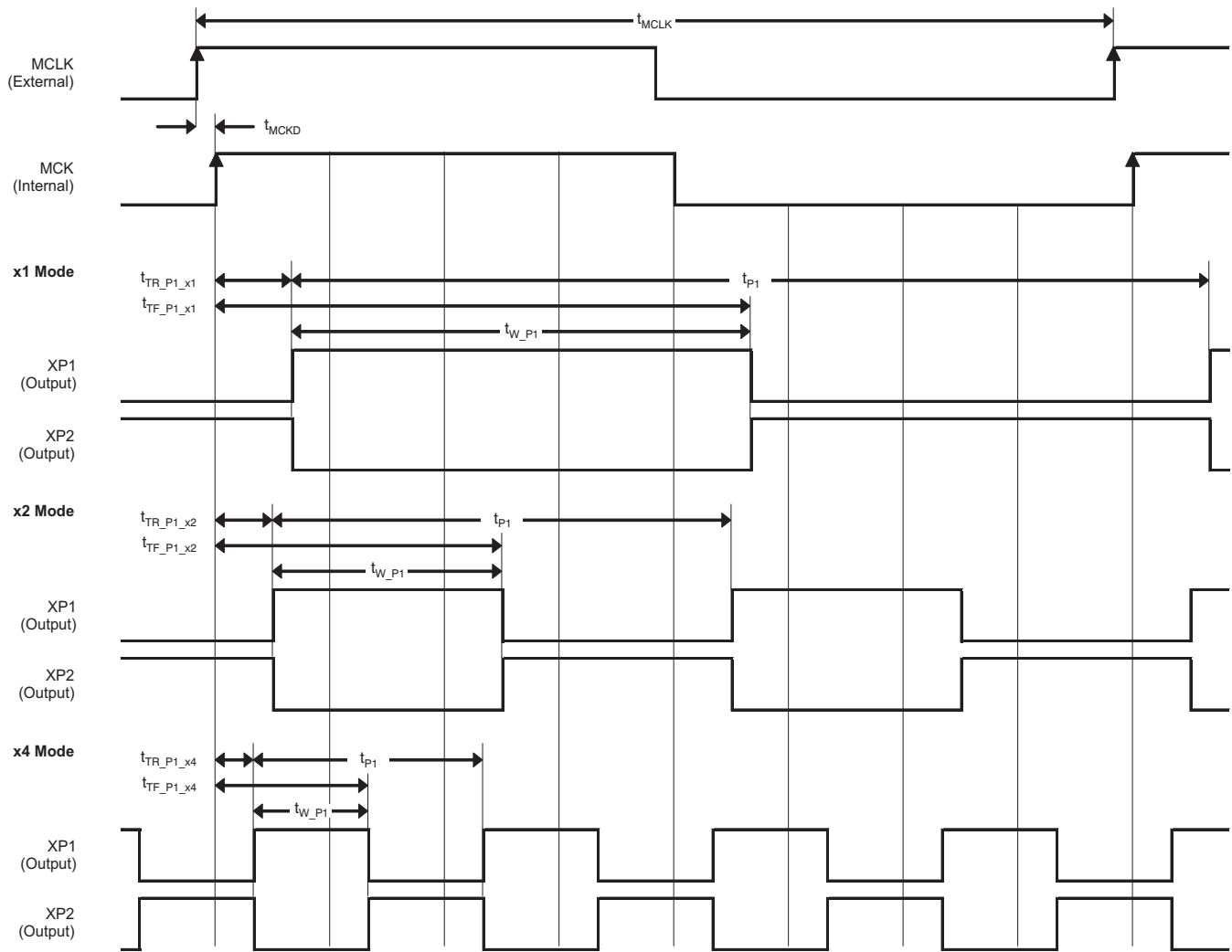

Figure 22. XP1 and XP2 Fast Transfer Clock Pulse Setting

**Table 14. Timing Requirements for Figure 22**

PARAMETER		TEST CONDITIONS	MIN	TYP	MAX	UNIT
f <sub>MCLK</sub>	MCLK frequency	VSP5610	1		11.66	MHz
		VSP5611	1		16.66	MHz
		VSP5612	1		23.33	MHz
t <sub>MCLK</sub>	MCLK period			1/f <sub>MCLK</sub>		ns
t <sub>MCKD</sub>	MCLK to MCK delay			2		ns
t <sub>Pn</sub>	XP1, XP2 period	x1 mode		t <sub>MCLK</sub>		ns
		x2 mode		t <sub>MCLK</sub> × 1/2		ns
		x4 mode		t <sub>MCLK</sub> × 1/4		ns
t <sub>TR_P_x1</sub>	XP1, XP2 rising edge delay from MCK	x1 mode	0	t <sub>MCLK</sub> × 47/48		ns
t <sub>TR_P_x2</sub>		x2 mode	0	t <sub>MCLK</sub> × 23/24		ns
t <sub>TR_P_x3</sub>		x4 mode	0	t <sub>MCLK</sub> × 11/12		ns
t <sub>TF_P_x1</sub>	XP1, XP2 falling edge delay from MCK	x1 mode	0	t <sub>MCLK</sub> × 47/48		ns
t <sub>TF_P_x2</sub>		x2 mode	0	t <sub>MCLK</sub> × 23/24		ns
t <sub>TF_P_x3</sub>		x4 mode	0	t <sub>MCLK</sub> × 11/12		ns
t <sub>W_P1</sub>	XP1, XP2 pulse width	x1 mode	2	t <sub>MCLK</sub> – 2		ns
		x2 mode	2	t <sub>MCLK</sub> × 1/2 – 2		ns
		x4 mode	2	t <sub>MCLK</sub> × 1/4 – 2		ns

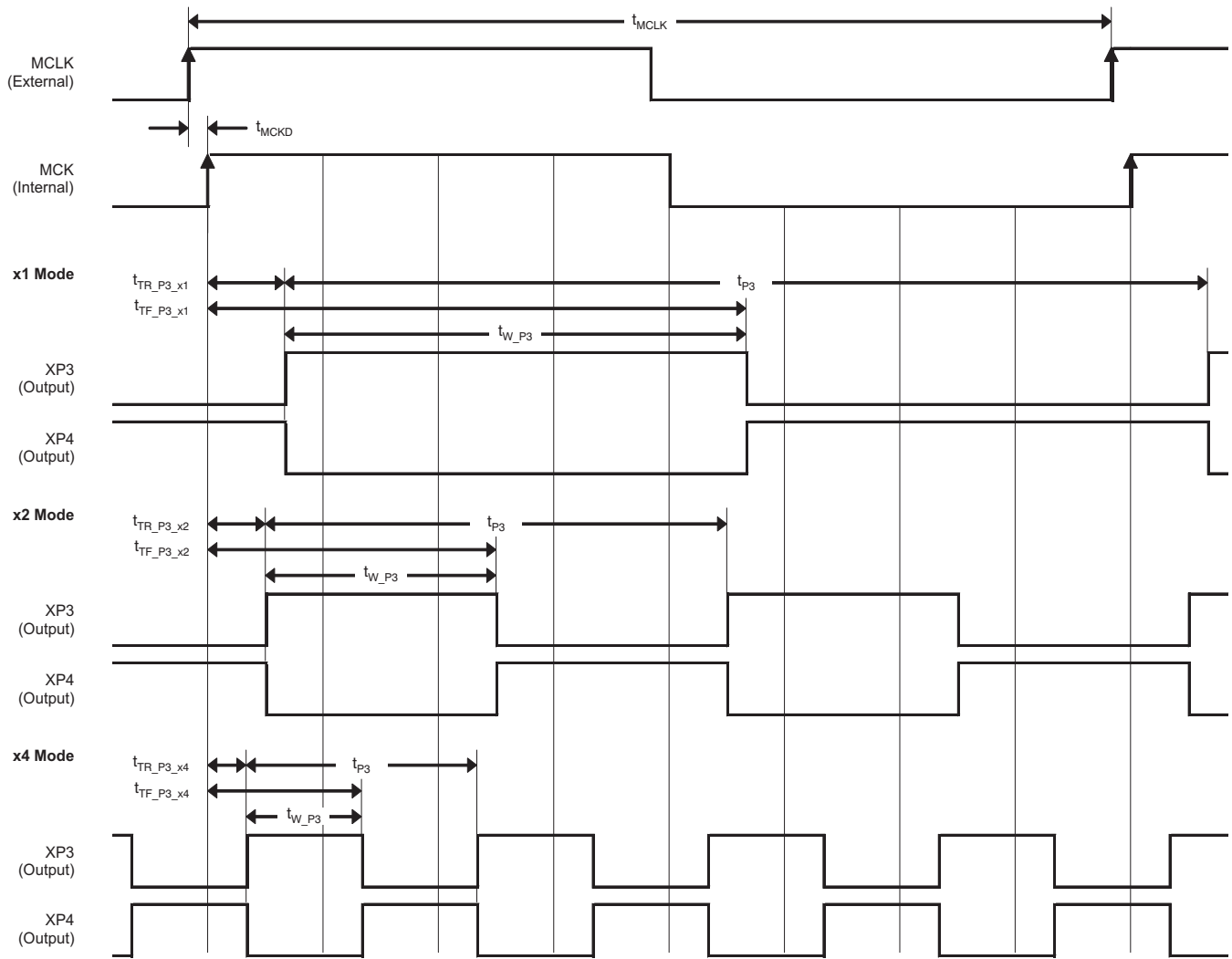

Figure 23. XP3 and XP4 Fast Transfer Clock Pulse Setting

**Table 15. Timing Requirements for Figure 23**

PARAMETER		TEST CONDITIONS	MIN	TYP	MAX	UNIT
f <sub>MCLK</sub>	MCLK frequency	VSP5610	1		11.66	MHz
		VSP5611	1		16.66	MHz
		VSP5612	1		23.33	MHz
t <sub>MCLK</sub>	MCLK period			1/f <sub>MCLK</sub>		ns
t <sub>MCKD</sub>	MCLK to MCK delay			2		ns
t <sub>P3</sub>	XP3, XP4 period	x1 mode		t <sub>MCLK</sub>		ns
		x2 mode		t <sub>MCLK</sub> × 1/2		ns
		x4 mode		t <sub>MCLK</sub> × 1/4		ns
t <sub>TR_P3_x1</sub>	XP3, XP4 rising edge delay from MCK	x1 mode	0	t <sub>MCLK</sub> × 47/48		ns
t <sub>TR_P3_x2</sub>		x2 mode	0	t <sub>MCLK</sub> × 23/24		ns
t <sub>TR_P3_x3</sub>		x4 mode	0	t <sub>MCLK</sub> × 11/12		ns
t <sub>TF_P3_x1</sub>	XP3, XP4 falling edge delay from MCK	x1 mode	0	t <sub>MCLK</sub> × 47/48		ns
t <sub>TF_P3_x2</sub>		x2 mode	0	t <sub>MCLK</sub> × 23/24		ns
t <sub>TF_P3_x3</sub>		x4 mode	0	t <sub>MCLK</sub> × 11/12		ns
t <sub>W_P3</sub>	XP3, XP4 pulse width	x1 mode	2	t <sub>MCLK</sub> – 2		ns
		x2 mode	2	t <sub>MCLK</sub> × 1/2 – 2		ns
		x4 mode	2	t <sub>MCLK</sub> × 1/4 – 2		ns

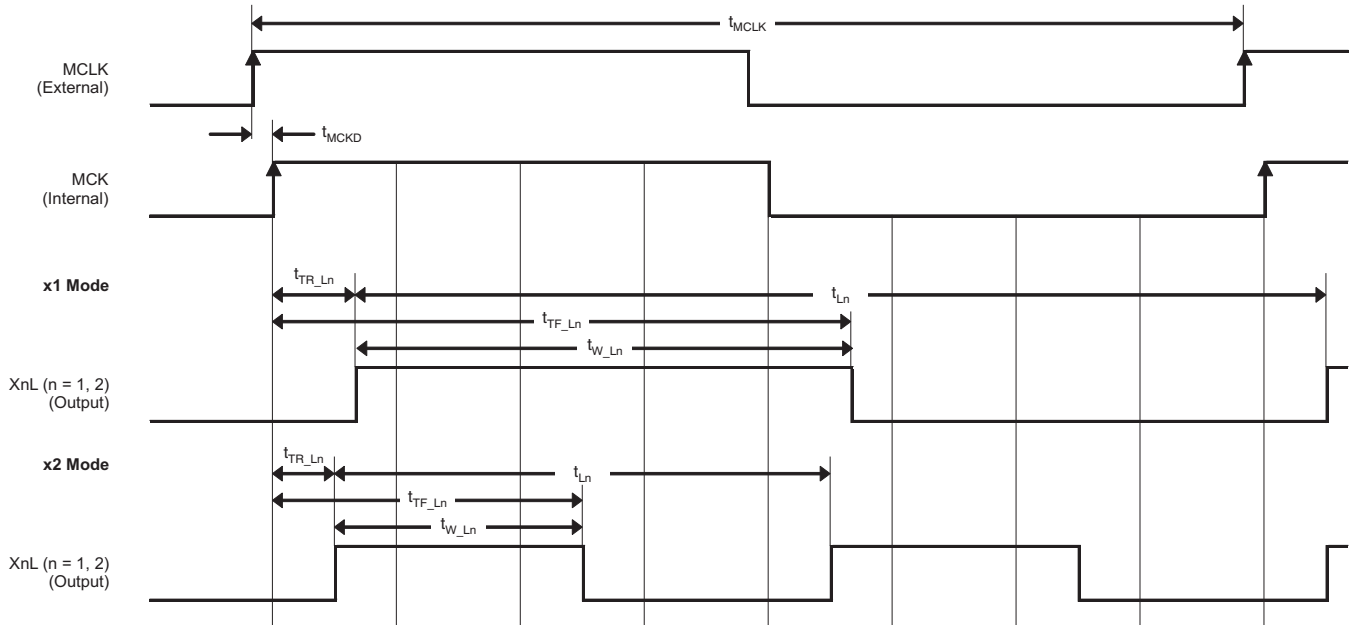

Figure 24. X1L and X2L Fast Transfer Clock Pulse Setting

Table 16. Timing Requirements for Figure 24

PARAMETER		TEST CONDITIONS	MIN	TYP	MAX	UNIT
f <sub>MCLK</sub>	MCLK frequency	VSP5610	1		11.66	MHz
		VSP5611	1		16.66	MHz
		VSP5612	1		23.33	MHz
t <sub>MCLK</sub>	MCLK period			1/f <sub>MCLK</sub>	ns	
t <sub>MCKD</sub>	MCLK to MCK delay			2	ns	
t <sub>Ln</sub>	X <sub>L</sub> <sub>n</sub> period (n = 1,2)	x1 mode		t <sub>MCLK</sub>		ns
		x2 mode		t <sub>MCLK</sub> × 1/2		ns
t <sub>TR_Ln</sub>	X <sub>L</sub> <sub>n</sub> rising edge delay from MCK (n = 1,2)	x1 mode	0	t <sub>MCLK</sub> × 47/48		ns
		x2 mode	0	t <sub>MCLK</sub> × 23/24		ns
t <sub>TF_Ln</sub>	X <sub>L</sub> <sub>n</sub> falling edge delay from MCK (n = 1,2)	x1 mode	0	t <sub>MCLK</sub> × 47/48		ns
		x2 mode	0	t <sub>MCLK</sub> × 23/24		ns
t <sub>W_Ln</sub>	X <sub>L</sub> <sub>n</sub> pulse width (n = 1,2)	x1 mode	2	t <sub>MCLK</sub> – 2		ns
		x2 mode	2	t <sub>MCLK</sub> × 1/2 – 2		ns

## SERIAL INTERFACE

All device functions and settings are controlled through the serial interface. The serial interface consists of three signals (SCLK, SEN, and SDI) for register writing, and a fourth signal (SDO) for readback. SDO shares the terminal with the GPIO signal; thus, a register setting is required to activate the SDO function. Other signals are assigned to individual terminals.

Serial data are composed of 30 bits total, as shown in Figure 25. 10 bits are assigned for the register address and 20 bits for register data. The input serial data at SDI are sequentially stored in a shift register at the SCLK rising edge. Data shift operation is performed at the SCLK rising edges with SEN low. All 30 input data bits are loaded to a parallel latch in an internal register at the rising edge of SEN.

This device has two modes: read and write. The mode selection can be made via the SPL\_RW internal register, located at bit 0 of address 0. SPL\_RW = 0 implies a write mode and SPL\_RW = 1 implies read mode.

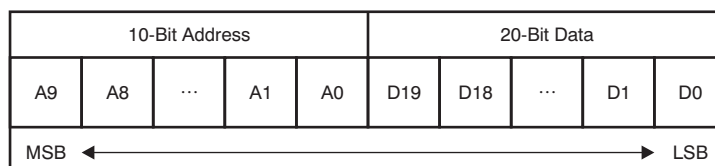

Figure 25. Serial I/F Data Format

### WRITE MODE (SPL\_RW = 0, Default)

Normally, one serial interface command is sent by one address and data combination. The address should be sent MSB first. Data are stored into the respective register, as indicated by the address. If the serial data at the end of the data stream are less than 30 bits, the last incomplete serial data are discarded. Figure 26 shows the SPI signal flow while in write mode.

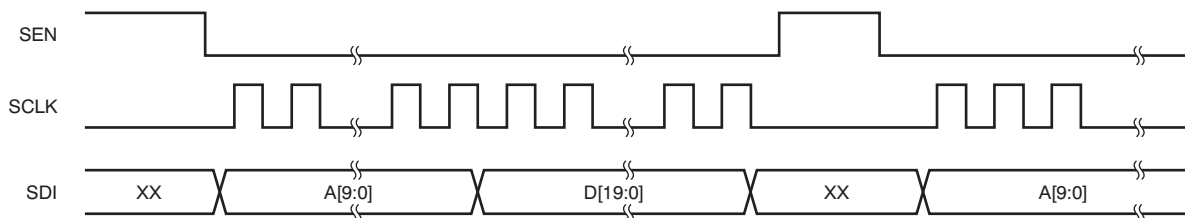

Figure 26. SPI Signal Flow of Write Mode

## READ MODE (SPI\_RW = 1)

In read mode, two types of connections are possible between the AFE and external systems such as an ASIC or CPU. One connection is the four-wire connection in which the SDI and SDO pins are separately connected to the system as shown in Figure 27a.

The other connection is a three-wire connection in which only the SDI pin is connected to the bidirectional I/O port of the external system, as shown in Figure 27b. In this case, SDI\_BUFF\_CTRL should be set to '1' to create an SPI bidirectional port. The bit flow of the four-wire connection is shown in Figure 28. The bit flow of the three-wire connection is shown in Figure 29. As shown in Figure 29, SDI changes from an input to an output at the SCLK falling edge after the end of the A[9:0] input. Because the SDI port is always in pull down mode, the external pull down resistance is unnecessary.

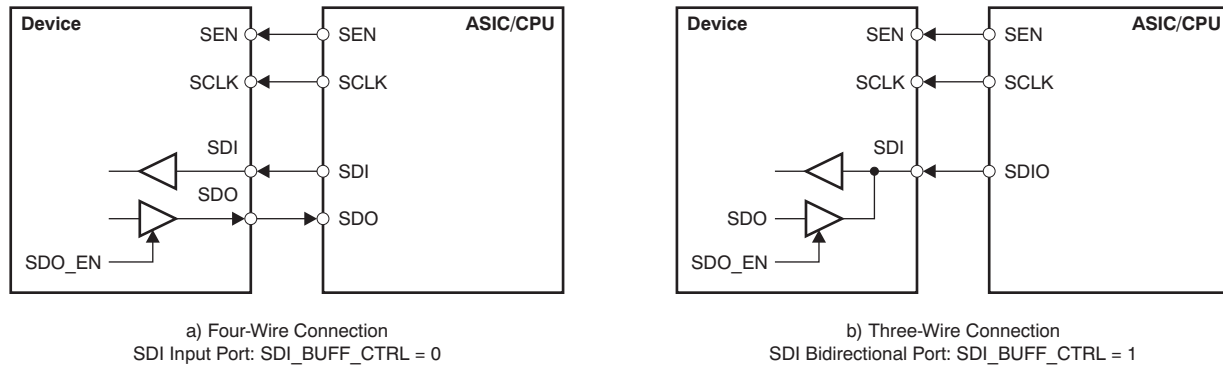

Figure 27. SPI Connection Between AFE and System

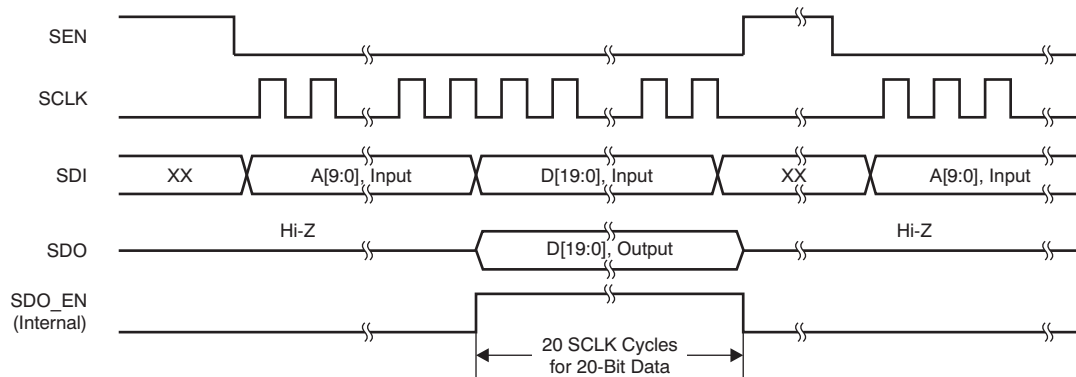

Figure 28. SPI Signal Flow of Read Mode for Four-Wire Connection

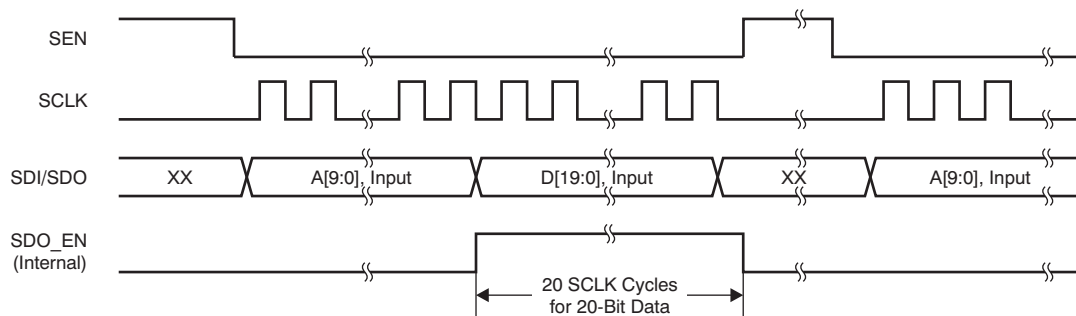

Figure 29. SPI Signal Flow of Read Mode for Three-Wire Connection

## 重要声明

德州仪器(TI) 及其下属子公司有权在不事先通知的情况下, 随时对所提供的产品和服务进行更正、修改、增强、改进或其它更改, 并有权随时中止提供任何产品和服务。客户在下订单前应获取最新的相关信息, 并验证这些信息是否完整且是最新的。所有产品的销售都遵循在订单确认时所提供的TI 销售条款与条件。

TI 保证其所销售的硬件产品的性能符合TI 标准保修的适用规范。仅在TI 保证的范围内, 且TI 认为有必要时才会使用测试或其它质量控制技术。除非政府做出了硬性规定, 否则没有必要对每种产品的所有参数进行测试。

TI 对应用帮助或客户产品设计不承担任何义务。客户应对其使用TI 组件的产品和应用自行负责。为尽量减小与客户产品和应用相关的风险, 客户应提供充分的设计与操作安全措施。

TI 不对任何TI 专利权、版权、屏蔽作品权或其它与使用了TI 产品或服务的组合设备、机器、流程相关的TI 知识产权中授予的直接或隐含权限作出任何保证或解释。TI 所发布的与第三方产品或服务有关的信息, 不能构成从TI 获得使用这些产品或服务的许可、授权、或认可。使用此类信息可能需要获得第三方的专利权或其它知识产权方面的许可, 或是TI 的专利权或其它知识产权方面的许可。

对于TI 的产品手册或数据表, 仅在没有对内容进行任何篡改且带有相关授权、条件、限制和声明的情况下才允许进行复制。在复制信息的过程中对内容的篡改属于非法的、欺诈性商业行为。TI 对此类篡改过的文件不承担任何责任。

在转售TI 产品或服务时, 如果存在对产品或服务参数的虚假陈述, 则会失去相关TI 产品或服务的明示或暗示授权, 且这是非法的、欺诈性商业行为。TI 对此类虚假陈述不承担任何责任。

TI 产品未获得用于关键的安全应用中的授权, 例如生命支持应用(在该类应用中一旦TI 产品故障将预计造成重大的人员伤亡), 除非各方官员已经达成了专门管控此类使用的协议。购买者的购买行为即表示, 他们具备有关其应用安全以及规章衍生所需的所有专业技术和知识, 并且认可和同意, 尽管任何应用相关信息或支持仍可能由TI 提供, 但他们将独力负责满足在关键安全应用中使用其产品及TI 产品所需的所有法律、法规和安全相关要求。此外, 购买者必须全额赔偿因在此类关键安全应用中使用TI 产品而对TI 及其代表造成的损失。

TI 产品并非设计或专门用于军事/航空应用, 以及环境方面的产品, 除非TI 特别注明该产品属于“军用”或“增强型塑料”产品。只有TI 指定的军用产品才满足军用规格。购买者认可并同意, 对TI 未指定军用的产品进行军事方面的应用, 风险由购买者单独承担, 并且独力负责在此类相关使用中满足所有法律和法规要求。

TI 产品并非设计或专门用于汽车应用以及环境方面的产品, 除非TI 特别注明该产品符合ISO/TS 16949 要求。购买者认可并同意, 如果他们在汽车应用中使用任何未被指定的产品, TI 对未能满足应用所需要求不承担任何责任。

可访问以下URL 地址以获取有关其它TI 产品和应用解决方案的信息:

	产品		应用
数字音频	<a href="http://www.ti.com.cn/audio">www.ti.com.cn/audio</a>	通信与电信	<a href="http://www.ti.com.cn/telecom">www.ti.com.cn/telecom</a>
放大器和线性器件	<a href="http://www.ti.com.cn/amplifiers">http://www.ti.com.cn/amplifiers</a>	计算机及周边	<a href="http://www.ti.com.cn/computer">www.ti.com.cn/computer</a>
数据转换器	<a href="http://www.ti.com.cn/dataconverters">http://www.ti.com.cn/dataconverters</a>	消费电子	<a href="http://www.ti.com/consumer-apps">www.ti.com/consumer-apps</a>
DLP® 产品	<a href="http://www.dlp.com">www.dlp.com</a>	能源	<a href="http://www.ti.com/energy">www.ti.com/energy</a>
DSP - 数字信号处理器	<a href="http://www.ti.com.cn/dsp">http://www.ti.com.cn/dsp</a>	工业应用	<a href="http://www.ti.com.cn/industrial">www.ti.com.cn/industrial</a>
时钟和计时器	<a href="http://www.ti.com.cn/clockandtimers">http://www.ti.com.cn/clockandtimers</a>	医疗电子	<a href="http://www.ti.com.cn/medical">www.ti.com.cn/medical</a>
接口	<a href="http://www.ti.com.cn/interface">http://www.ti.com.cn/interface</a>	安防应用	<a href="http://www.ti.com.cn/security">www.ti.com.cn/security</a>
逻辑	<a href="http://www.ti.com.cn/logic">http://www.ti.com.cn/logic</a>	汽车电子	<a href="http://www.ti.com.cn/automotive">www.ti.com.cn/automotive</a>
电源管理	<a href="http://www.ti.com.cn/power">http://www.ti.com.cn/power</a>	视频和影像	<a href="http://www.ti.com.cn/video">www.ti.com.cn/video</a>
微控制器 (MCU)	<a href="http://www.ti.com.cn/microcontrollers">http://www.ti.com.cn/microcontrollers</a>	无线通信	<a href="http://www.ti.com.cn/wireless">www.ti.com.cn/wireless</a>
RFID 系统	<a href="http://www.ti.com.cn/rfidsys">http://www.ti.com.cn/rfidsys</a>		
RF/IF 和 ZigBee® 解决方案	<a href="http://www.ti.com.cn/radiofre">www.ti.com.cn/radiofre</a>		
	TI E2E 工程师社区		<a href="http://e2e.ti.com/cn/">http://e2e.ti.com/cn/</a>

邮寄地址: 上海市浦东新区世纪大道 1568 号, 中建大厦 32 楼 邮政编码: 200122  
Copyright © 2011 德州仪器 半导体技术(上海)有限公司

**PACKAGING INFORMATION**

Orderable Device	Status (1)	Package Type	Package Drawing	Pins	Package Qty	Eco Plan (2)	Lead/Ball Finish (6)	MSL Peak Temp (3)	Op Temp (°C)	Device Marking (4/5)	Samples
VSP5610RSHR	ACTIVE	VQFN	RSH	56	2500	Green (RoHS & no Sb/Br)	CU NIPDAU	Level-3-260C-168 HR	0 to 85	VSP 5610	<a href="#">Samples</a>
VSP5611RSHR	ACTIVE	VQFN	RSH	56	2500	Green (RoHS & no Sb/Br)	CU NIPDAU	Level-3-260C-168 HR	0 to 85	VSP 5611	<a href="#">Samples</a>
VSP5612RSHR	ACTIVE	VQFN	RSH	56	2500	Green (RoHS & no Sb/Br)	CU NIPDAU	Level-3-260C-168 HR	0 to 85	VSP 5612	<a href="#">Samples</a>

(1) The marketing status values are defined as follows:

**ACTIVE:** Product device recommended for new designs.

**LIFEBUY:** TI has announced that the device will be discontinued, and a lifetime-buy period is in effect.

**NRND:** Not recommended for new designs. Device is in production to support existing customers, but TI does not recommend using this part in a new design.

**PREVIEW:** Device has been announced but is not in production. Samples may or may not be available.

**OBsolete:** TI has discontinued the production of the device.

(2) Eco Plan - The planned eco-friendly classification: Pb-Free (RoHS), Pb-Free (RoHS Exempt), or Green (RoHS & no Sb/Br) - please check <http://www.ti.com/productcontent> for the latest availability information and additional product content details.

**TBD:** The Pb-Free/Green conversion plan has not been defined.

**Pb-Free (RoHS):** TI's terms "Lead-Free" or "Pb-Free" mean semiconductor products that are compatible with the current RoHS requirements for all 6 substances, including the requirement that lead not exceed 0.1% by weight in homogeneous materials. Where designed to be soldered at high temperatures, TI Pb-Free products are suitable for use in specified lead-free processes.

**Pb-Free (RoHS Exempt):** This component has a RoHS exemption for either 1) lead-based flip-chip solder bumps used between the die and package, or 2) lead-based die adhesive used between the die and leadframe. The component is otherwise considered Pb-Free (RoHS compatible) as defined above.

**Green (RoHS & no Sb/Br):** TI defines "Green" to mean Pb-Free (RoHS compatible), and free of Bromine (Br) and Antimony (Sb) based flame retardants (Br or Sb do not exceed 0.1% by weight in homogeneous material)

(3) MSL, Peak Temp. - The Moisture Sensitivity Level rating according to the JEDEC industry standard classifications, and peak solder temperature.

(4) There may be additional marking, which relates to the logo, the lot trace code information, or the environmental category on the device.

(5) Multiple Device Markings will be inside parentheses. Only one Device Marking contained in parentheses and separated by a "~" will appear on a device. If a line is indented then it is a continuation of the previous line and the two combined represent the entire Device Marking for that device.

(6) Lead/Ball Finish - Orderable Devices may have multiple material finish options. Finish options are separated by a vertical ruled line. Lead/Ball Finish values may wrap to two lines if the finish value exceeds the maximum column width.

**Important Information and Disclaimer:** The information provided on this page represents TI's knowledge and belief as of the date that it is provided. TI bases its knowledge and belief on information provided by third parties, and makes no representation or warranty as to the accuracy of such information. Efforts are underway to better integrate information from third parties. TI has taken and

continues to take reasonable steps to provide representative and accurate information but may not have conducted destructive testing or chemical analysis on incoming materials and chemicals. TI and TI suppliers consider certain information to be proprietary, and thus CAS numbers and other limited information may not be available for release.

In no event shall TI's liability arising out of such information exceed the total purchase price of the TI part(s) at issue in this document sold by TI to Customer on an annual basis.

**RSH 56**

**GENERIC PACKAGE VIEW**

**VQFN - 1 mm max height**

PLASTIC QUAD FLATPACK - NO LEAD

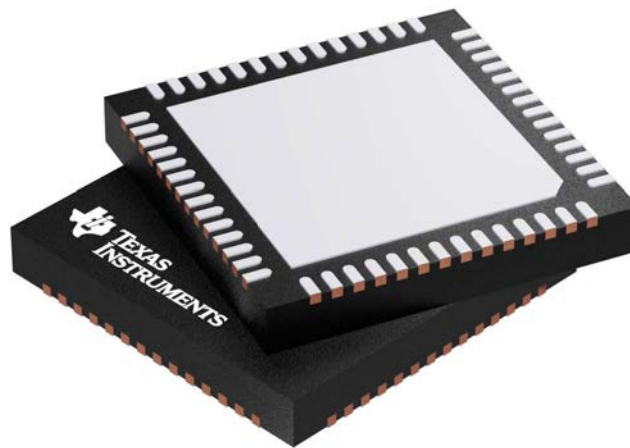

Images above are just a representation of the package family, actual package may vary.  
Refer to the product data sheet for package details.

4207513/D

# MECHANICAL DATA

RSH (S-PVQFN-N56)

PLASTIC QUAD FLATPACK NO-LEAD

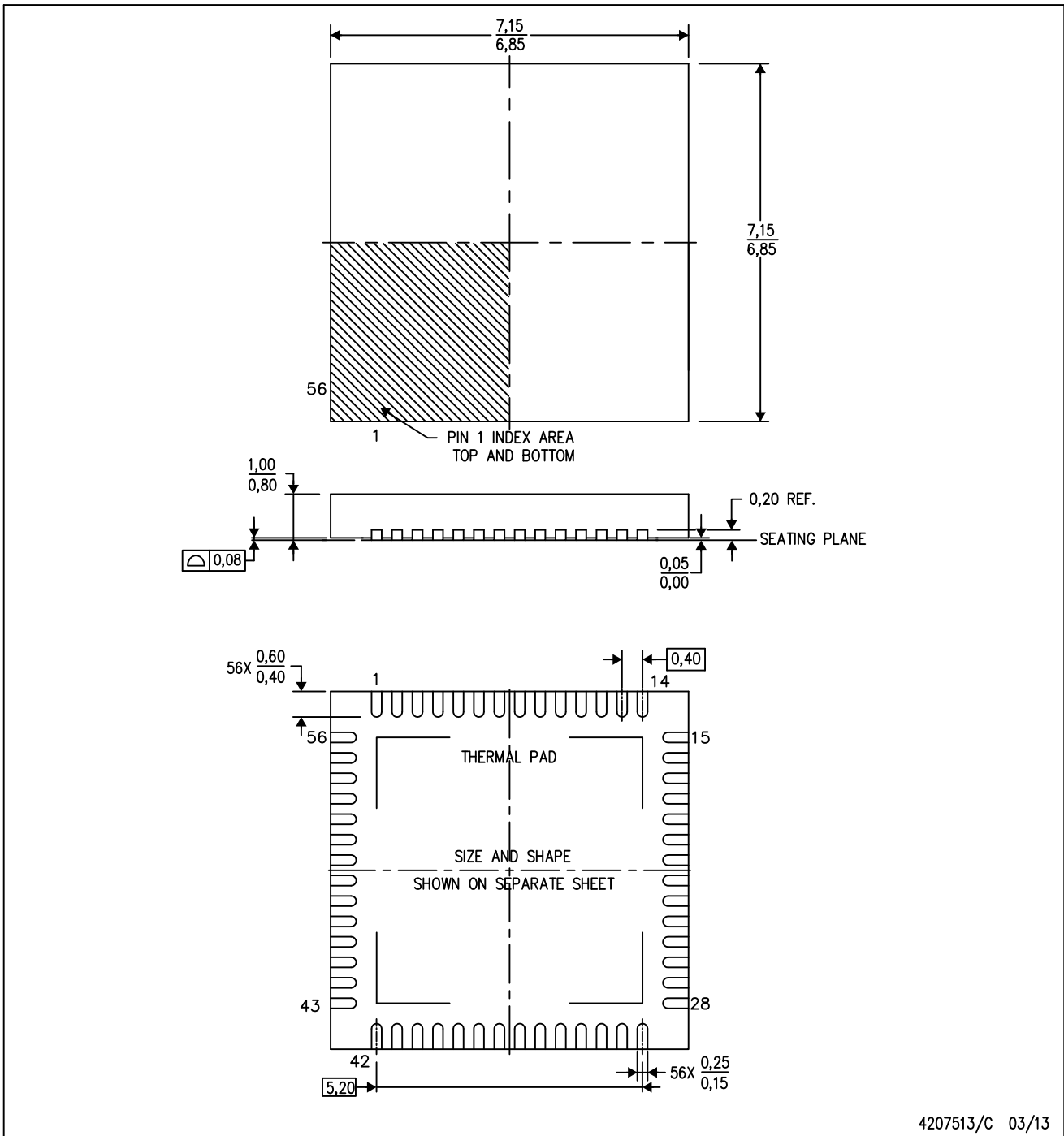

- NOTES:
- A. All linear dimensions are in millimeters. Dimensioning and tolerancing per ASME Y14.5M-1994.
  - B. This drawing is subject to change without notice.
  - C. Quad Flatpack, No-leads (QFN) package configuration.
  - D. The package thermal pad must be soldered to the board for thermal and mechanical performance.
  - E. See the additional figure in the Product Data Sheet for details regarding the exposed thermal pad features and dimensions.

## THERMAL PAD MECHANICAL DATA

RSH (S-PVQFN-N56)

PLASTIC QUAD FLATPACK NO-LEAD

### THERMAL INFORMATION

This package incorporates an exposed thermal pad that is designed to be attached directly to an external heatsink. The thermal pad must be soldered directly to the printed circuit board (PCB). After soldering, the PCB can be used as a heatsink. In addition, through the use of thermal vias, the thermal pad can be attached directly to the appropriate copper plane shown in the electrical schematic for the device, or alternatively, can be attached to a special heatsink structure designed into the PCB. This design optimizes the heat transfer from the integrated circuit (IC).

For information on the Quad Flatpack No-Lead (QFN) package and its advantages, refer to Application Report, QFN/SON PCB Attachment, Texas Instruments Literature No. SLUA271. This document is available at [www.ti.com](http://www.ti.com).

The exposed thermal pad dimensions for this package are shown in the following illustration.

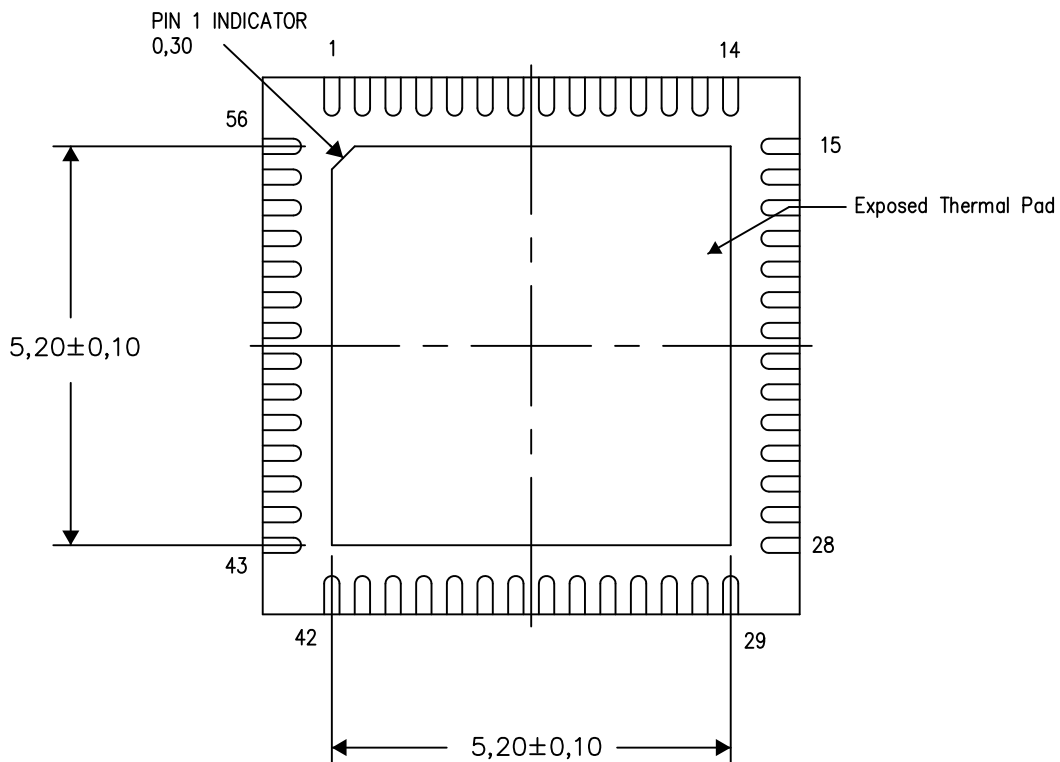

Bottom View

Exposed Thermal Pad Dimensions

4207553-2/1 07/13

NOTE: All linear dimensions are in millimeters

RSH (S-PVQFN-N56)

PLASTIC QUAD FLATPACK NO-LEAD

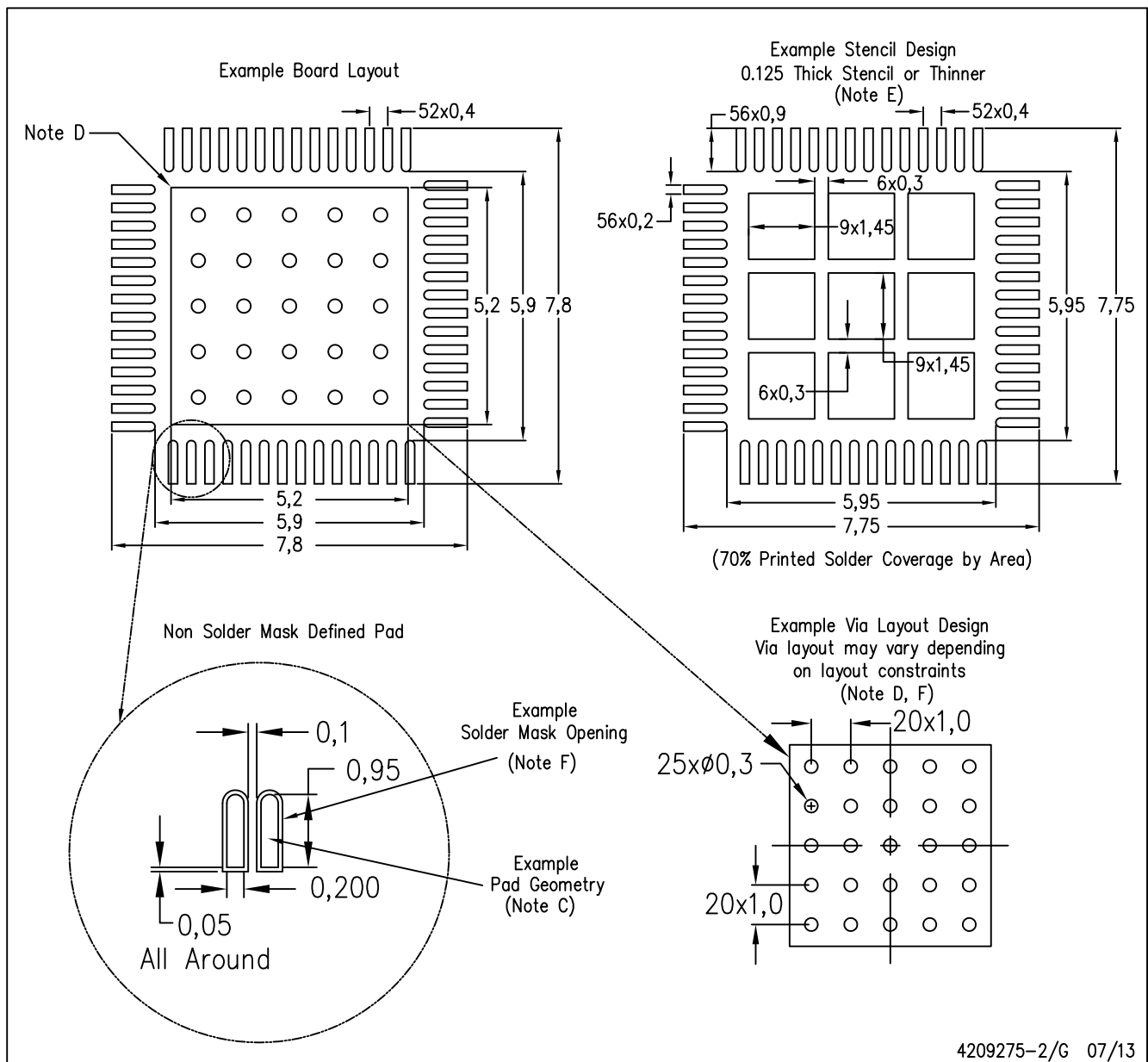

- NOTES:
- All linear dimensions are in millimeters.
  - This drawing is subject to change without notice.
  - Publication IPC-7351 is recommended for alternate designs.
  - This package is designed to be soldered to a thermal pad on the board. Refer to Application Note, Quad Flat-Pack Packages, Texas Instruments Literature No. SLUA271, and also the Product Data Sheets for specific thermal information, via requirements, and recommended board layout. These documents are available at [www.ti.com](http://www.ti.com) <<http://www.ti.com>>.
  - Laser cutting apertures with trapezoidal walls and also rounding corners will offer better paste release. Customers should contact their board assembly site for stencil design recommendations. Refer to IPC 7525 for stencil design considerations.
  - Customers should contact their board fabrication site for recommended solder mask tolerances and via tenting recommendations for vias placed in the thermal pad.

## 重要声明

德州仪器 (TI) 公司有权按照最新发布的 JESD46 对其半导体产品和服务进行纠正、增强、改进和其他修改，并不再按最新发布的 JESD48 提供任何产品和服务。买方在下订单前应获取最新的相关信息，并验证这些信息是否完整且是最新的。

TI 公布的半导体产品销售条款 (<http://www.ti.com/sc/docs/stdterms.htm>) 适用于 TI 已认证和批准上市的已封装集成电路产品的销售。另有其他条款可能适用于其他类型 TI 产品及服务的使用或销售。

复制 TI 数据表上 TI 信息的重要部分时，不得变更该等信息，且必须随附所有相关保证、条件、限制和通知，否则不得复制。TI 对该等复制文件不承担任何责任。第三方信息可能受到其它限制条件的制约。在转售 TI 产品或服务时，如果存在对产品或服务参数的虚假陈述，则会失去相关 TI 产品或服务的明示或暗示保证，且构成不公平的、欺诈性商业行为。TI 对此类虚假陈述不承担任何责任。

买方和在系统中整合 TI 产品的其他开发人员（总称“设计人员”）理解并同意，设计人员在设计应用时应自行实施独立的分析、评价和判断，且应全权负责并确保应用的安全性，及设计人员的应用（包括应用中使用的 TI 产品）应符合所有适用的法律法规及其他相关要求。设计人员就自己设计的应用声明，其具备制订和实施下列保障措施所需的一切必要专业知识，能够 (1) 预见故障的危险后果，(2) 监视故障及其后果，以及 (3) 降低可能导致危险的故障几率并采取适当措施。设计人员同意，在使用或分发包含 TI 产品的任何应用前，将彻底测试该等应用和该等应用中所用 TI 产品的功能。

TI 提供技术、应用或其他设计建议、质量特点、可靠性数据或其他服务或信息，包括但不限于与评估模块有关的参考设计和材料（总称“TI 资源”），旨在帮助设计人员开发整合了 TI 产品的应用，如果设计人员（个人，或如果是代表公司，则为设计人员的公司）以任何方式下载、访问或使用任何特定的 TI 资源，即表示其同意仅为该等目标，按照本通知的条款使用任何特定 TI 资源。

TI 所提供的 TI 资源，并未扩大或以其他方式修改 TI 对 TI 产品的公开适用的质保及质保免责声明；也未导致 TI 承担任何额外的义务或责任。TI 有权对其 TI 资源进行纠正、增强、改进和其他修改。除特定 TI 资源的公开文档中明确列出的测试外，TI 未进行任何其他测试。

设计人员只有在开发包含该等 TI 资源所列 TI 产品的应用时，才被授权使用、复制和修改任何相关 TI 资源。但并未依据禁止反言原则或其他法律授予您任何 TI 知识产权的任何其他明示或默示的许可，也未授予您 TI 或第三方的任何技术或知识产权的许可，该等许可包括但不限于任何专利权、版权、屏蔽作品权或与美国 TI 产品或服务的相关整合、机器制作、流程相关的其他知识产权。涉及或参考了第三方产品或服务的信息不构成使用此类产品或服务的许可或与其相关的保证或认可。使用 TI 资源可能需要您向第三方获得对该等第三方专利或其他知识产权的许可。

TI 资源系“按原样”提供。TI 兹免除对资源及其使用作出所有其他明确或默示的保证或陈述，包括但不限于对准确性或完整性、产权保证、无屡发故障保证，以及适销性、适合特定用途和不侵犯任何第三方知识产权的任何默认保证。TI 不负责任何申索，包括但不限于因组合产品所致或与之有关的申索，也不为或对设计人员进行辩护或赔偿，即使该等产品组合已列于 TI 资源或其他地方。对因 TI 资源或其使用引起或与之有关的任何实际的、直接的、特殊的、附带的、间接的、惩罚性的、偶发的、从属或惩戒性损害赔偿，不管 TI 是否获悉可能会产生上述损害赔偿，TI 概不负责。

除 TI 已明确指出特定产品已达到特定行业标准（例如 ISO/TS 16949 和 ISO 26262）的要求外，TI 不对未达到任何该等行业标准要求而承担任何责任。

如果 TI 明确宣称产品有助于功能安全或符合行业功能安全标准，则该等产品旨在帮助客户设计和创作自己的符合相关功能安全标准和要求的的应用。在应用内使用产品的行为本身不会配有安全特性。设计人员必须确保遵守适用于其应用的相关安全要求和标准。设计人员不可将任何 TI 产品用于关乎性命的医疗设备，除非已由各方获得授权的管理人员签署专门的合同对此类应用专门作出规定。关乎性命的医疗设备是指出现故障会导致严重身体伤害或死亡的医疗设备（例如生命保障设备、心脏起搏器、心脏除颤器、人工心脏泵、神经刺激器以及植入设备）。此类设备包括但不限于，美国食品药品监督管理局认定为 III 类设备的设备，以及在美国以外的其他国家或地区认定为同等类别设备的所有医疗设备。

TI 可能明确指定某些产品具备某些特定资格（例如 Q100、军用级或增强型产品）。设计人员同意，其具备一切必要专业知识，可以为自己的应用选择适合的产品，并且正确选择产品的风险由设计人员承担。设计人员单方面负责遵守与该等选择有关的所有法律或监管要求。

设计人员同意向 TI 及其代表全额赔偿因其不遵守本通知条款和条件而引起的任何损害、费用、损失和/或责任。

邮寄地址：上海市浦东新区世纪大道 1568 号中建大厦 32 楼，邮政编码：200122  
Copyright © 2017 德州仪器半导体技术（上海）有限公司