

ADS79xx-Q1 8 位, 10 位和 12 位, 1MSPS, 4 通道, 8 通道, 12 通道和 16 通道, 单端, 低功耗, 串行接口, 模数转换器

1 特性

- 符合汽车应用要求
- 具有经 AEC-Q100 测试的下列结果:
 - 器件温度 1 级: -40°C 至 125°C 的环境运行温度范围
 - 器件人体模型 (HBM) 静电放电 (ESD) 分类等级 H2
 - 器件充电器件模型 (CDM) ESD 分类等级 C4B
- 产品系列:
 - 8 位, 10 位和 12 位分辨率
 - 4 通道、8 通道和 12 通道器件与 16 通道器件均采用相同封装尺寸
- 1MHz 采样率串行器件
- 模拟电源范围: 2.7V 至 5.25V
- I/O 电源范围: 1.7V 至 5.25V
- 两个软件可选单极、输入范围:
 - (0V 至 2.5V) 或 (0V 至 5V)
- 针对通道选择的自动和手动模式
- 每通道两个可编程警报级别
- 四个独立可配置通用输入输出 (GPIO) 接口
- 典型功率耗散值: 1MSPS 下为 14.5mW ($V_{(+VA)} = 5V$, $(+VBD) = 3V$)
- 断电电流 (1 μ A)
- 30 引脚和 38 引脚薄型小外形尺寸 (TSSOP) 封装

2 应用范围

- 车载系统
- 电源监控
- 电池供电系统
- 高速、数据采集系统

3 说明

ADS79xx-Q1 器件系列由多通道 8 位, 10 位和 12 位模数转换器 (ADC) 组成。此器件包括一个基于电容器的逐次逼近寄存器 (SAR) ADC, 此 ADC 支持固有的采样保持。多特性和出色性能使得 ADS79xx-Q1 器件可用于需要对多条通道进行监控的广泛应用。

ADS79xx-Q1 器件在 2.7V 至 5.25V 的宽模拟电源范围内运行。由于功耗极低, 这些器件非常适合于电池供电和隔离式电源供电的应用。

4 通道和 8 通道器件采用 30 引脚 TSSOP 封装。12 通道和 16 通道器件采用 38 引脚 TSSOP 封装。

器件信息⁽¹⁾

器件名称	封装	封装尺寸
ADS7950-Q1	TSSOP (30)	7.80mm x 4.40mm
ADS7951-Q1		
ADS7954-Q1		
ADS7958-Q1		
ADS7959-Q1		
ADS7952-Q1	TSSOP (38)	9.70mm x 4.40mm
ADS7953-Q1		
ADS7956-Q1		
ADS7957-Q1		
ADS7960-Q1		
ADS7961-Q1		

(1) 要了解所有可用封装, 请见数据表末尾的可订购产品附录。

详细方框图

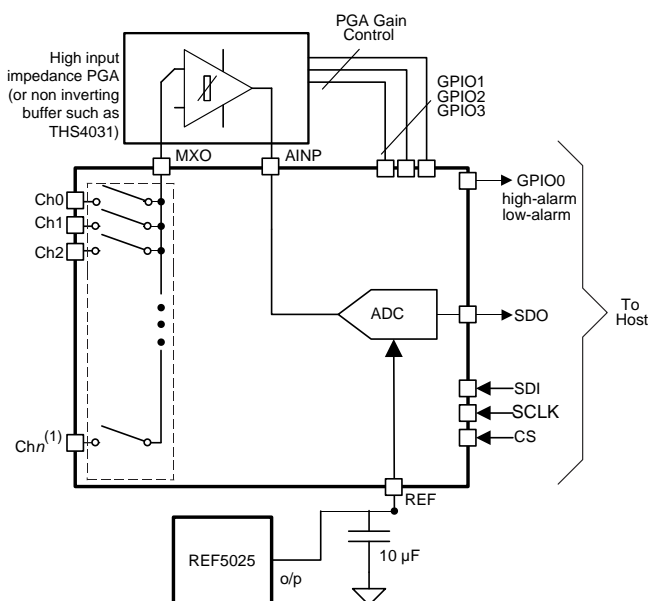

目录

1	特性	1	8.1	Overview	20
2	应用范围	1	8.2	Functional Block Diagram	20
3	说明	1	8.3	Feature Description	21
4	修订历史记录	2	8.4	Device Functional Modes	25
5	Device Comparison Table	3	8.5	Digital Output Code	35
6	Pin Configurations and Functions	3	8.6	Programming: GPIO	36
7	Specifications	5	9	Application and Implementation	40
7.1	Absolute Maximum Ratings	5	9.1	Application Information	40
7.2	Handling Ratings	5	9.2	Typical Applications	40
7.3	Recommended Operating Conditions	6	9.3	Do's and Don'ts	42
7.4	Thermal Information	6	10	Power-Supply Recommendations	42
7.5	Electrical Characteristics: ADS7950-Q1, ADS7951-Q1, ADS7952-Q1, ADS7953-Q1	6	11	Layout	43
7.6	Electrical Characteristics: ADS7954-Q1, ADS7956-Q1, ADS7957-Q1	8	11.1	Layout Guidelines	43
7.7	Electrical Characteristics: ADS7958-Q1, ADS7959-Q1, ADS7960-Q1, ADS7961-Q1	9	11.2	Layout Example	43
7.8	Timing Requirements	11	12	器件和文档支持	44
7.9	Typical Characteristics (All ADS79xx-Q1 Family Devices)	12	12.1	文档支持	44
7.10	Typical Characteristics (12-Bit Devices Only)	13	12.2	相关链接	44
8	Detailed Description	20	12.3	商标	44
			12.4	静电放电警告	44
			12.5	术语表	44
			13	机械封装和可订购信息	44

4 修订历史记录

Changes from Original (May 2014) to Revision A	Page
• 在器件信息表中添加了所有器件	1
• Deleted Device Comparison Table footnote	3
• Changed entire <i>Application and Implementation</i> section	40

5 Device Comparison Table

NUMBER OF CHANNELS	RESOLUTION		
	12 BIT	10 BIT	8 BIT
4	ADS7950-Q1	ADS7954-Q1	ADS7958-Q1
8	ADS7951-Q1	—	ADS7959-Q1
12	ADS7952-Q1	ADS7956-Q1	ADS7960-Q1
16	ADS7953-Q1	ADS7957-Q1	ADS7961-Q1

6 Pin Configurations and Functions

**DBT Package
TSSOP-30
(Top View)**

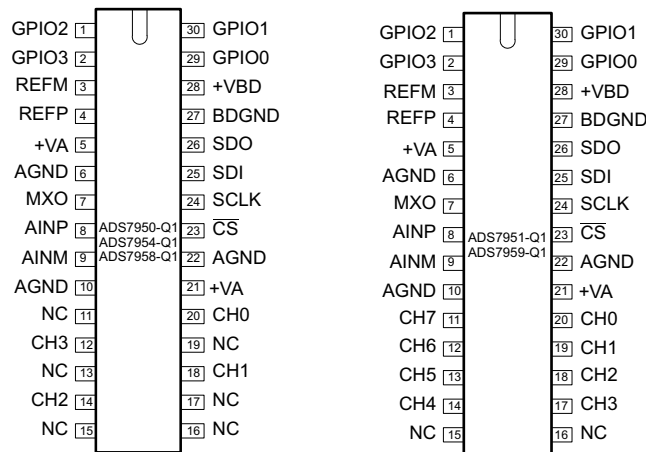

NC = No internal connection

**DBT Package
TSSOP-38
(Top View)**

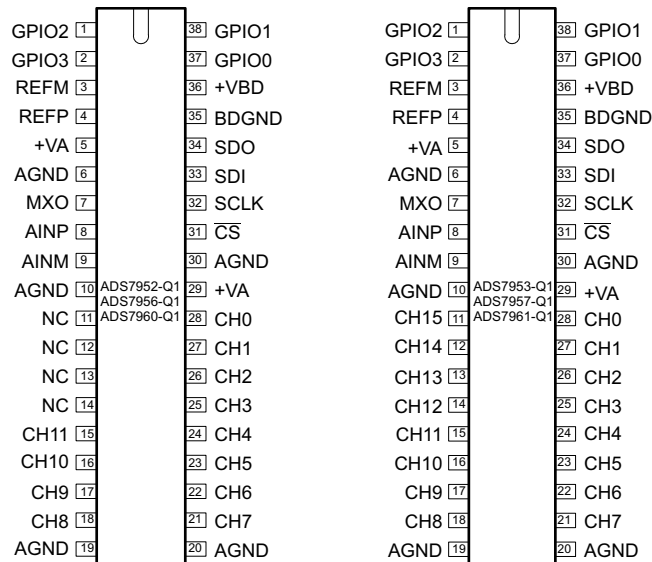

Pin Functions

NAME	PIN NUMBER				I/O	DESCRIPTION
	ADS7953-Q1, ADS7957-Q1, ADS7961-Q1	ADS7952-Q1, ADS7956-Q1, ADS7960-Q1	ADS7951-Q1, ADS7959-Q1	ADS7950-Q1, ADS7954-Q1, ADS7958-Q1		
ADC ANALOG INPUT						
AINM	9	9	9	9	I	ADC input ground
AINP	8	8	8	8	I	Signal input to ADC
DIGITAL CONTROL SIGNALS						
\overline{CS}	31	31	23	23	I	Chip-select input
SCLK	32	32	24	24	I	Serial clock input
SDI	33	33	25	25	I	Serial data input
SDO	34	34	26	26	O	Serial data output
GENERAL PURPOSE INPUTS AND OUTPUTS⁽¹⁾						
GPIO0	37	37	29	29	I/O	General-purpose input or output
High or low alarm					O	Active high output indicating high alarm or low alarm, depending on programming
GPIO1	38	38	30	30	I/O	General-purpose input or output
Low alarm					O	Active high output indicating low alarm
GPIO2	1	1	1	1	I/O	General-purpose input or output
Range					I	Selects range: High → Range 2; Low → Range 1
GPIO3	2	2	2	2	I/O	General-purpose input or output
\overline{PD}					I	Active low power-down input
MULTIPLEXER						
Ch0	28	28	20	20	I	Analog channels for multiplexer
Ch1	27	27	19	18	I	
Ch2	26	26	18	14	I	
Ch3	25	25	17	12	I	
Ch4	24	24	14	—	I	
Ch5	23	23	13	—	I	
Ch6	22	22	12	—	I	
Ch7	21	21	11	—	I	
Ch8	18	18	—	—	I	
Ch9	17	17	—	—	I	
Ch10	16	16	—	—	I	
Ch11	15	15	—	—	I	
Ch12	14	—	—	—	I	
Ch13	13	—	—	—	I	
Ch14	12	—	—	—	I	
Ch15	11	—	—	—	I	
MXO	7	7	7	7	O	Multiplexer output
NC PINS						
NC	—	11	15	11	—	Pins internally not connected, do not float these pins
		12	16	13		
		13	—	15		
		14	—	16		
		—	—	17		
		—	—	19		

(1) These pins have programmable dual functionality. See [Table 12](#) for functionality programming.

Pin Functions (continued)

NAME	PIN NUMBER				I/O	DESCRIPTION
	ADS7953-Q1, ADS7957-Q1, ADS7961-Q1	ADS7952-Q1, ADS7956-Q1, ADS7960-Q1	ADS7951-Q1, ADS7959-Q1	ADS7950-Q1, ADS7954-Q1, ADS7958-Q1		
POWER SUPPLY AND GROUND						
AGND	6	6	6	6	—	Analog ground
	10	10	10	10		
	19	19	22	22		
	20	20	—	—		
	30	30	—	—		
BDGND	35	35	27	27	—	Digital ground
+VA	5	5	5	5	—	Analog power supply
	29	29	21	21		
+VBD	36	36	28	28	—	Digital I/O supply
REFERENCE						
REFM	3	3	3	3	I	Reference ground
REFP	4	4	4	4	I	Reference input

7 Specifications

7.1 Absolute Maximum Ratings⁽¹⁾

over operating free-air temperature range (unless otherwise noted).

		MIN	MAX	UNIT
Supply voltage to ground	+VA to AGND, +VBD to BDGND	−0.3	7	V
Signal input	AINP or CHn to AGND	−0.3	$V_{(+VA)} + 0.3$	V
Digital input	To BDGND	−0.3	7	V
Digital output	To BDGND	−0.3	$V_{(+VA)} + 0.3$	V
Junction temperature, T_J			150	°C

(1) Stresses beyond those listed as *absolute maximum ratings* may cause permanent damage to the device. These are stress ratings only, and functional operation of the device at these or any other conditions beyond those indicated as *recommended operating conditions* is not implied. Exposure to absolute-maximum-rated conditions for extended periods may affect device reliability.

7.2 Handling Ratings

		MIN	MAX	UNIT	
T_{stg}	Storage temperature range	−65	150	°C	
$V_{(ESD)}$	Electrostatic discharge	Human-body model (HBM), per AEC Q100-002 ⁽¹⁾ , level H2		kV	
		Charged-device model (CDM), per AEC Q100-001, level C4B	Corner pins (1, 15, 16, and 30 for 30-pin packages 1, 19, 20, and 38 for 38-pin packages)		V
			All pins		V

(1) AEC Q100-002 indicates HBM stressing is done in accordance with the ANSI/ESDA/JEDEC JS-001 specification.

7.3 Recommended Operating Conditions

over operating free-air temperature range (unless otherwise noted)

		MIN	NOM	MAX	UNIT
$V_{(+VA)}$	Analog power-supply voltage	2.7	3.3	5.25	V
$V_{(+VBD)}$	Digital I/O-supply voltage	1.7	3.3	$V_{(+VA)}$	V
$V_{(REF)}$	Reference voltage	2	2.5	3	V
$f_{(SCLK)}$	SCLK frequency			20	MHz
T_A	Operating temperature range	–40		125	°C

7.4 Thermal Information

THERMAL METRIC ⁽¹⁾	ADS79xx-Q1		UNIT	
	DBT (TSSOP)	DBT (TSSOP)		
	38 PINS	30 PINS		
$R_{\theta JA}$	Junction-to-ambient thermal resistance	83.6	89.8	°C/W
$R_{\theta JC(top)}$	Junction-to-case (top) thermal resistance	29.8	22.9	
$R_{\theta JB}$	Junction-to-board thermal resistance	44.7	43.1	
Ψ_{JT}	Junction-to-top characterization parameter	2.9	0.8	
Ψ_{JB}	Junction-to-board characterization parameter	44.1	42.5	
$R_{\theta JC(bot)}$	Junction-to-case (bottom) thermal resistance	n/a	n/a	

(1) For more information about traditional and new thermal metrics, see the *IC Package Thermal Metrics* application report, [SPRA953](#).

7.5 Electrical Characteristics: ADS7950-Q1, ADS7951-Q1, ADS7952-Q1, ADS7953-Q1

$V_{(+VA)} = 2.7\text{ V to }5.25\text{ V}$, $V_{(+VBD)} = 1.7\text{ V to }V_{(+VA)}$, $V_{ref} = 2.5\text{ V} \pm 0.1\text{ V}$, $T_A = -40^\circ\text{C to }125^\circ\text{C}$, $f_{sample} = 1\text{ MHz}$ (unless otherwise noted)

PARAMETER	TEST CONDITIONS	MIN	TYP	MAX	UNIT
ANALOG INPUT					
Full-scale input span ⁽¹⁾	Range 1	0		V_{ref}	V
	Range 2 while $2 \times V_{ref} \leq +VA$	0		$2 \times V_{ref}$	V
Absolute input range	Range 1	–0.2		$V_{ref} + 0.2$	V
	Range 2 while $2 \times V_{ref} \leq +VA$	–0.2		$2 \times V_{ref} + 0.2$	V
Input capacitance			15		pF
Input leakage current	$T_A = 125^\circ\text{C}$		61		nA
SYSTEM PERFORMANCE					
Resolution			12		Bits
No missing codes		11			Bits
Integral linearity		–1.5	± 0.75	1.5	LSB ⁽²⁾
Differential linearity		–2	± 0.75	1.5	LSB
Offset error ⁽³⁾		–3.5	± 1.1	3.5	LSB
Gain error	Range 1	–2	± 0.2	2	LSB
	Range 2		± 0.2		LSB
TUE Total unadjusted error			± 2		LSB
SAMPLING DYNAMICS					
Conversion time	20-MHz SCLK			800	ns
Acquisition time		325			ns
Maximum throughput rate	20-MHz SCLK			1	MHz
Aperture delay			5		ns
Step response			150		ns
Over voltage recovery			150		ns

(1) Ideal input span; does not include gain or offset error.

(2) LSB means least-significant bit.

(3) Measured relative to an ideal full-scale input

Electrical Characteristics: ADS7950-Q1, ADS7951-Q1, ADS7952-Q1, ADS7953-Q1 (continued)
 $V_{(+VA)} = 2.7\text{ V to }5.25\text{ V}$, $V_{(+VBD)} = 1.7\text{ V to }V_{(+VA)}$, $V_{ref} = 2.5\text{ V} \pm 0.1\text{ V}$, $T_A = -40^\circ\text{C to }125^\circ\text{C}$, $f_{sample} = 1\text{ MHz}$ (unless otherwise noted)

PARAMETER		TEST CONDITIONS	MIN	TYP	MAX	UNIT
DYNAMIC CHARACTERISTICS						
THD	Total harmonic distortion ⁽⁴⁾	100 kHz		-82		dB
SNR	Signal-to-noise ratio	100 kHz	70	71.7		dB
SINAD	Signal-to-noise + distortion	100 kHz	68	71.3		dB
SFDR	Spurious-free dynamic range	100 kHz		84		dB
	Small signal bandwidth	At -3 dB		47		MHz
	Channel-to-channel crosstalk	Any off-channel with 100 kHz. Full-scale input to channel being sampled with DC input (isolation crosstalk).		-95		dB
		From previously sampled to channel with 100 kHz. Full-scale input to channel being sampled with DC input (memory crosstalk).		-85		dB
EXTERNAL REFERENCE INPUT						
V_{ref}	Reference voltage at REFP ⁽⁵⁾		2	2.5	3	V
R_{ref}	Reference resistance			100		k Ω
ALARM SETTING						
	Higher threshold range		0		FFC	Hex
	Lower threshold range		0		FFC	Hex
DIGITAL INPUT/OUTPUT (CMOS Logic Family)						
V_{IH}	High logic-level input voltage		$0.7 \times V_{(+VBD)}$			V
V_{IL}	Low logic-level input voltage	$V_{(+VA)} = 5\text{ V}$			0.8	V
		$V_{(+VA)} = 3\text{ V}$			0.4	V
V_{OH}	High logic-level output voltage	At source current (I_S) = 200 μA	$V_{(+VBD)} - 0.2$			V
V_{OL}	Low logic-level output voltage	At $I_{sink} = 200\text{ }\mu\text{A}$	0.4			V
	Data format MSB first		MSB first			
POWER SUPPLY REQUIREMENTS						
$V_{(+VA)}$	Analog power-supply voltage		2.7	3.3	5.25	V
$V_{(+VBD)}$	Digital I/O-supply voltage		1.7	3.3	$V_{(+VA)}$	V
$I_{(+VA)}$	Supply current (normal mode)	At $V_{(+VA)} = 2.7\text{ V to }3.6\text{ V}$ and 1-MHz throughput		1.8		mA
		At $V_{(+VA)} = 2.7\text{ V to }3.6\text{ V}$ static state		1.05		mA
		At $V_{(+VA)} = 4.7\text{ V to }5.25\text{ V}$ and 1-MHz throughput		2.3	3	mA
		At $V_{(+VA)} = 4.7\text{ V to }5.25\text{ V}$ static state		1.1	1.5	mA
	Power-down state supply current			1		μA
$I_{(+VBD)}$	Digital I/O-supply current	$V_{(+VA)} = 5.25\text{ V}$, $f_{sample} = 1\text{ MHz}$		1		mA
	Power-up time				1	μs
	Invalid conversions after power up or reset				1	cycle
	Latch-up		JESD78 class I			
TEMPERATURE RANGE						
	Specified performance		-40		125	$^\circ\text{C}$

(4) Calculated on the first nine harmonics of the input frequency.

(5) The device is designed to operate over $V_{ref} = 2\text{ V to }3\text{ V}$. However, lower noise performance can be expected at $V_{ref} < 2.4\text{ V}$, because of SNR degradation resulting from lowered signal range.

7.6 Electrical Characteristics: ADS7954-Q1, ADS7956-Q1, ADS7957-Q1

$V_{(+VA)} = 2.7\text{ V to }5.25\text{ V}$, $V_{(+VBD)} = 1.7\text{ V to }V_{(+VA)}$, $V_{ref} = 2.5\text{ V} \pm 0.1\text{ V}$, $T_A = -40^\circ\text{C to }125^\circ\text{C}$, $f_{sample} = 1\text{ MHz}$ (unless otherwise noted)

PARAMETER	TEST CONDITIONS	MIN	TYP	MAX	UNIT	
ANALOG INPUT						
Full-scale input span ⁽¹⁾	Range 1	0		V_{ref}	V	
	Range 2 while $2 \times V_{ref} \leq +VA$	0		$2 \times V_{ref}$	V	
Absolute input range	Range 1	-0.2		$V_{ref} + 0.2$	V	
	Range 2 while $2 \times V_{ref} \leq +VA$	-0.2		$2 \times V_{ref} + 0.2$	V	
Input capacitance			15		pF	
Input leakage current	$T_A = 125^\circ\text{C}$		61		nA	
SYSTEM PERFORMANCE						
Resolution			10		Bits	
No missing codes		10			Bits	
Integral linearity		-0.5	± 0.2	0.5	LSB ⁽²⁾	
Differential linearity		-0.5	± 0.2	0.5	LSB	
Offset error ⁽³⁾		-1.5	± 0.5	1.5	LSB	
Gain error	Range 1	-1	± 0.1	1	LSB	
	Range 2		± 0.1		LSB	
SAMPLING DYNAMICS						
Conversion time	20-MHz SCLK			800	ns	
Acquisition time		325			ns	
Maximum throughput rate	20-MHz SCLK			1	MHz	
Aperture delay			5		ns	
Step response			150		ns	
Over voltage recovery			150		ns	
DYNAMIC CHARACTERISTICS						
THD	Total harmonic distortion ⁽⁴⁾	100 kHz		-80	dB	
SNR	Signal-to-noise ratio	100 kHz	60		dB	
SINAD	Signal-to-noise + distortion	100 kHz	60		dB	
SFDR	Spurious-free dynamic range	100 kHz		82	dB	
	Full-power bandwidth	At -3 dB		47	MHz	
Channel-to-channel crosstalk	Any off-channel with 100 kHz. Full-scale input to channel being sampled with dc input.			-95	dB	
	From previously sampled to channel with 100 kHz. Full-scale input to channel being sampled with dc input.			-85	dB	
EXTERNAL REFERENCE INPUT						
V_{ref}	Reference voltage at REFP		2	2.5	3	V
R_{ref}	Reference resistance			100		k Ω
ALARM SETTING						
	Higher threshold range		000	FFC	Hex	
	Lower threshold range		000	FFC	Hex	
DIGITAL INPUT/OUTPUT (CMOS Logic Family)						
V_{IH}	High logic-level input voltage		$0.7 \times V_{(+VBD)}$		V	
V_{IL}	Low logic-level input voltage	$V_{(+VBD)} = 5\text{ V}$		0.8	V	
		$V_{(+VBD)} = 3\text{ V}$		0.4	V	
V_{OH}	High logic-level output voltage	At source current (I_S) = 200 μA		$V_{(+VBD)} - 0.2$	V	
V_{OL}	Low logic-level output voltage	At $I_{sink} = 200\ \mu\text{A}$	0.4		V	
	Data format MSB first			MSB first		

- (1) Ideal input span; does not include gain or offset error.
- (2) LSB means least significant bit.
- (3) Measured relative to an ideal full-scale input
- (4) Calculated on the first nine harmonics of the input frequency.

Electrical Characteristics: ADS7954-Q1, ADS7956-Q1, ADS7957-Q1 (continued)
 $V_{(+VA)} = 2.7\text{ V to }5.25\text{ V}$, $V_{(+VBD)} = 1.7\text{ V to }V_{(+VA)}$, $V_{ref} = 2.5\text{ V} \pm 0.1\text{ V}$, $T_A = -40^\circ\text{C to }125^\circ\text{C}$, $f_{sample} = 1\text{ MHz}$ (unless otherwise noted)

PARAMETER	TEST CONDITIONS	MIN	TYP	MAX	UNIT	
POWER SUPPLY REQUIREMENTS						
$V_{(+VA)}$	Analog power-supply voltage	2.7	3.3	5.25	V	
$V_{(+VBD)}$	Digital I/O-supply voltage	1.7	3.3	$V_{(+VA)}$	V	
$I_{(+VA)}$	Supply current (normal mode)	At $V_{(+VA)} = 2.7\text{ V to }3.6\text{ V}$ and 1-MHz throughput		1.8	mA	
		At $V_{(+VA)} = 2.7\text{ V to }3.6\text{ V}$ static state		1.05	1	mA
		At $V_{(+VA)} = 4.7\text{ V to }5.25\text{ V}$ and 1-MHz throughput		2.3	3	mA
		At $V_{(+VA)} = 4.7\text{ V to }5.25\text{ V}$ static state		1.1	1.5	mA
	Power-down state supply current		1		μA	
$I_{(+VBD)}$	Digital I/O-supply current	$V_{(+VA)} = 5.25\text{ V}$, $f_{sample} = 1\text{ MHz}$		1	mA	
	Power-up time			1	μs	
	Invalid conversions after power up or reset			1	cycle	
	Latch-up	JESD78 class I				
TEMPERATURE RANGE						
	Specified performance	-40		125	$^\circ\text{C}$	

7.7 Electrical Characteristics: ADS7958-Q1, ADS7959-Q1, ADS7960-Q1, ADS7961-Q1
 $V_{(+VA)} = 2.7\text{ V to }5.25\text{ V}$, $V_{(+VBD)} = 1.7\text{ V to }V_{(+VA)}$, $V_{ref} = 2.5\text{ V} \pm 0.1\text{ V}$, $T_A = -40^\circ\text{C to }125^\circ\text{C}$, $f_{sample} = 1\text{ MHz}$ (unless otherwise noted)

PARAMETER	TEST CONDITIONS	MIN	TYP	MAX	UNIT
ANALOG INPUT					
Full-scale input span ⁽¹⁾	Range 1	0		V_{ref}	V
	Range 2 while $2 \times V_{ref} \leq +VA$	0		$2 \times V_{ref}$	V
Absolute input range	Range 1	-0.20		$V_{ref} + 0.2$	V
	Range 2 while $2 \times V_{ref} \leq +VA$	-0.20		$2 \times V_{ref} + 0.2$	V
Input capacitance			15		pF
Input leakage current	$T_A = 125^\circ\text{C}$		61		nA
SYSTEM PERFORMANCE					
Resolution			8		Bits
No missing codes			8		Bits
Integral linearity		-0.3	± 0.1	0.3	LSB ⁽²⁾
Differential linearity		-0.3	± 0.1	0.3	LSB
Offset error ⁽³⁾		-0.5	± 0.2	0.5	LSB
Gain error	Range 1	-0.6	± 0.1	0.6	LSB
	Range 2		± 0.1		LSB
SAMPLING DYNAMICS					
Conversion time	20-MHz SCLK			800	ns
Acquisition time			325		ns
Maximum throughput rate	20-MHz SCLK			1	MHz
Aperture delay			5		ns
Step response			150		ns
Over voltage recovery			150		ns

(1) Ideal input span; does not include gain or offset error.

(2) LSB means least significant bit.

(3) Measured relative to an ideal full-scale input

Electrical Characteristics: ADS7958-Q1, ADS7959-Q1, ADS7960-Q1, ADS7961-Q1 (continued)

$V_{(+VA)} = 2.7\text{ V to }5.25\text{ V}$, $V_{(+VBD)} = 1.7\text{ V to }V_{(+VA)}$, $V_{ref} = 2.5\text{ V} \pm 0.1\text{ V}$, $T_A = -40^\circ\text{C to }125^\circ\text{C}$, $f_{sample} = 1\text{ MHz}$ (unless otherwise noted)

PARAMETER		TEST CONDITIONS	MIN	TYP	MAX	UNIT
DYNAMIC CHARACTERISTICS						
THD	Total harmonic distortion ⁽⁴⁾	100 kHz		-75		dB
SNR	Signal-to-noise ratio	100 kHz		49		dB
SINAD	Signal-to-noise + distortion	100 kHz		49		dB
SFDR	Spurious-free dynamic range	100 kHz		-78		dB
	Full-power bandwidth	At -3 dB		47		MHz
	Channel-to-channel crosstalk	Any off-channel with 100 kHz. Full-scale input to channel being sampled with dc input.		-95		dB
		From previously sampled to channel with 100 kHz. Full-scale input to channel being sampled with dc input.		-85		dB
EXTERNAL REFERENCE INPUT						
V _{ref}	reference voltage at REFP		2	2.5	3	V
	Reference resistance			100		kΩ
ALARM SETTING						
	Higher threshold range		000		FF	Hex
	Lower threshold range		000		FF	Hex
DIGITAL INPUT/OUTPUT (CMOS Logic Family)						
V _{IH}	High logic-level input voltage		0.7 × V _(+VBD)			V
V _{IL}	Low logic-level input voltage	V _(+VBD) = 5 V			0.8	V
		V _(+VBD) = 3 V			0.4	V
V _{OH}	High logic-level output voltage	At source current (I _S) = 200 μA	V _(+VBD) - 0.2			V
V _{OL}	Low logic-level output voltage	At I _{sink} = 200 μA	0.4			V
	Data format		MSB first			
POWER SUPPLY REQUIREMENTS						
V _(+VA)	Analog power-supply voltage		2.7	3.3	5.25	V
V _(+VBD)	Digital I/O-supply voltage		1.7	3.3	V _(+VA)	V
I _(+VA)	Supply current (normal mode)	At V _(+VA) = 2.7 V to 3.6 V and 1-MHz throughput		1.8		mA
		At V _(+VA) = 2.7 V to 3.6 V static state		1.05		mA
		At V _(+VA) = 4.7 V to 5.25 V and 1-MHz throughput		2.3	3	mA
		At V _(+VA) = 4.7 V to 5.25 V static state		1.1	1.5	mA
	Power-down state supply current			1		μA
I _(+VBD)	Digital I/O-supply current	V _(+VA) = 5.25 V, f _{sample} = 1 MHz		1		mA
	Power-up time				1	μs
	Invalid conversions after power up or reset				1	cycle
	Latch-up		JESD78 class I			
TEMPERATURE RANGE						
	Specified performance		-40		125	°C

(4) Calculated on the first nine harmonics of the input frequency.

7.8 Timing Requirements

All specifications typical at -40°C to 125°C , $V_{(+V_A)} = 2.7\text{ V}$ to 5.25 V (unless otherwise specified). See [Figure 45](#), [Figure 46](#), [Figure 47](#), and [Figure 48](#).

PARAMETER ⁽¹⁾⁽²⁾		MIN	TYP	MAX	UNIT
t_c	Conversion time	$V_{(+V_{BD})} = 1.8\text{ V}$		16	SCLK
		$V_{(+V_{BD})} = 3\text{ V}$		16	SCLK
		$V_{(+V_{BD})} = 5\text{ V}$		16	SCLK
t_q	Minimum quiet sampling time needed from bus Tri-state to start of next conversion	$V_{(+V_{BD})} = 1.8\text{ V}$	40		ns
		$V_{(+V_{BD})} = 3\text{ V}$	40		ns
		$V_{(+V_{BD})} = 5\text{ V}$	40		ns
t_{d1}	Delay time, $\overline{\text{CS}}$ low to first data (DO–15) out	$V_{(+V_{BD})} = 1.8\text{ V}$		38	ns
		$V_{(+V_{BD})} = 3\text{ V}$		27	ns
		$V_{(+V_{BD})} = 5\text{ V}$		17	ns
t_{su1}	Setup time, $\overline{\text{CS}}$ low to first rising edge of SCLK	$V_{(+V_{BD})} = 1.8\text{ V}$	8		ns
		$V_{(+V_{BD})} = 3\text{ V}$	6		ns
		$V_{(+V_{BD})} = 5\text{ V}$	4		ns
t_{d2}	Delay time, SCLK falling to SDO next data bit valid	$V_{(+V_{BD})} = 1.8\text{ V}$		35	ns
		$V_{(+V_{BD})} = 3\text{ V}$		27	ns
		$V_{(+V_{BD})} = 5\text{ V}$		17	ns
t_{h1}	Hold time, SCLK falling to SDO data bit valid	$V_{(+V_{BD})} = 1.8\text{ V}$	7		ns
		$V_{(+V_{BD})} = 3\text{ V}$	5		ns
		$V_{(+V_{BD})} = 5\text{ V}$	3		ns
t_{d3}	Delay time, 16th SCLK falling edge to SDO 3-state	$V_{(+V_{BD})} = 1.8\text{ V}$		26	ns
		$V_{(+V_{BD})} = 3\text{ V}$		22	ns
		$V_{(+V_{BD})} = 5\text{ V}$		13	ns
t_{su2}	Setup time, SDI valid to rising edge of SCLK	$V_{(+V_{BD})} = 1.8\text{ V}$	2		ns
		$V_{(+V_{BD})} = 3\text{ V}$	3		ns
		$V_{(+V_{BD})} = 5\text{ V}$	4		ns
t_{h2}	Hold time, rising edge of SCLK to SDI valid	$V_{(+V_{BD})} = 1.8\text{ V}$	12		ns
		$V_{(+V_{BD})} = 3\text{ V}$	10		ns
		$V_{(+V_{BD})} = 5\text{ V}$	6		ns
t_{w1}	Pulse duration $\overline{\text{CS}}$ high	$V_{(+V_{BD})} = 1.8\text{ V}$	20		ns
		$V_{(+V_{BD})} = 3\text{ V}$	20		ns
		$V_{(+V_{BD})} = 5\text{ V}$	20		ns
t_{d4}	Delay time $\overline{\text{CS}}$ high to SDO 3-state	$V_{(+V_{BD})} = 1.8\text{ V}$		24	ns
		$V_{(+V_{BD})} = 3\text{ V}$		21	ns
		$V_{(+V_{BD})} = 5\text{ V}$		12	ns
t_{wH}	Pulse duration SCLK high	$V_{(+V_{BD})} = 1.8\text{ V}$	20		ns
		$V_{(+V_{BD})} = 3\text{ V}$	20		ns
		$V_{(+V_{BD})} = 5\text{ V}$	20		ns
t_{wL}	Pulse duration SCLK low	$V_{(+V_{BD})} = 1.8\text{ V}$	20		ns
		$V_{(+V_{BD})} = 3\text{ V}$	20		ns
		$V_{(+V_{BD})} = 5\text{ V}$	20		ns
$f_{(\text{SCLK})}$	Frequency SCLK	$V_{(+V_{BD})} = 1.8\text{ V}$		20	MHz
		$V_{(+V_{BD})} = 3\text{ V}$		20	MHz
		$V_{(+V_{BD})} = 5\text{ V}$		20	MHz

(1) 1.8-V specifications apply from 1.7 V to 1.9 V, 3-V specifications apply from 2.7 V to 3.6 V, 5-V specifications apply from 4.75 V to 5.25 V.

(2) With 50-pF load

7.9 Typical Characteristics (All ADS79xx-Q1 Family Devices)

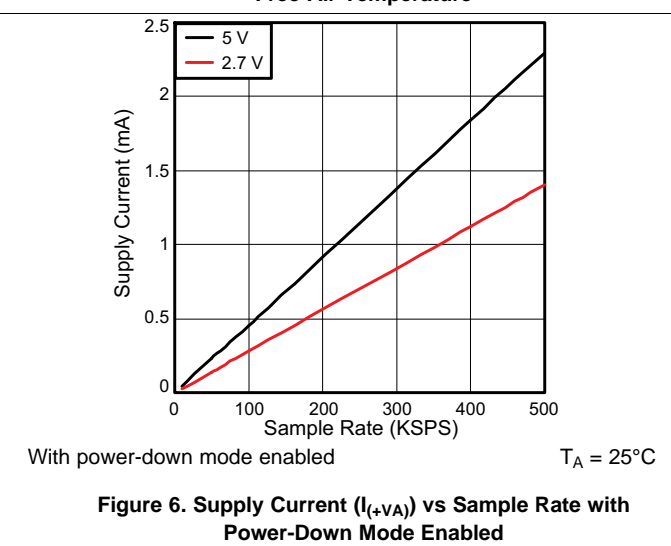
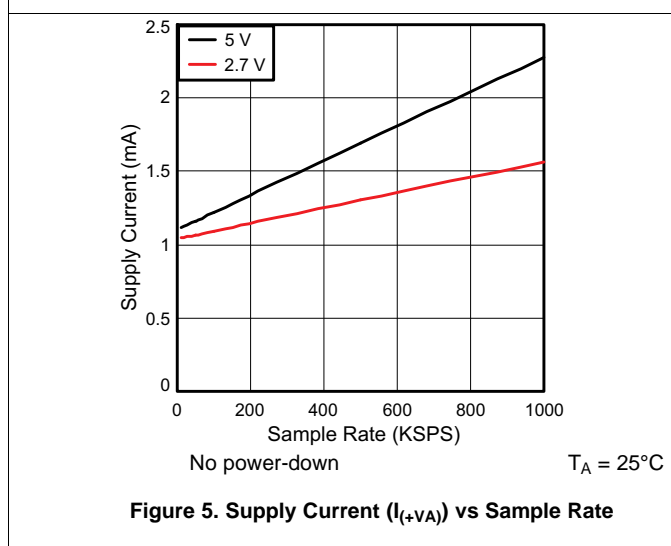
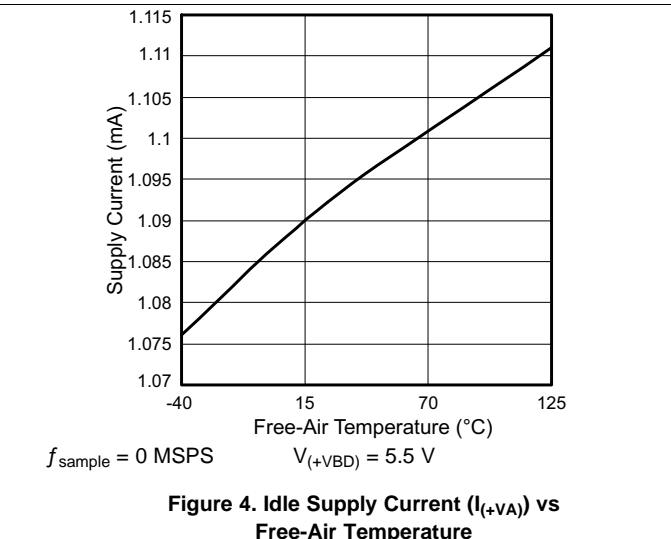
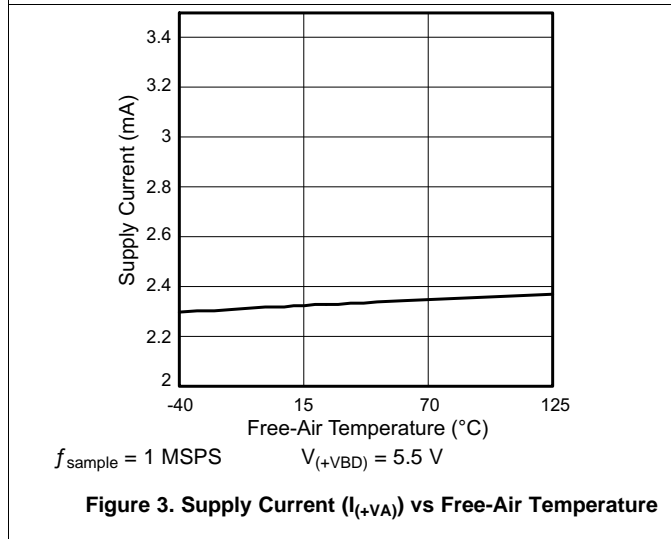
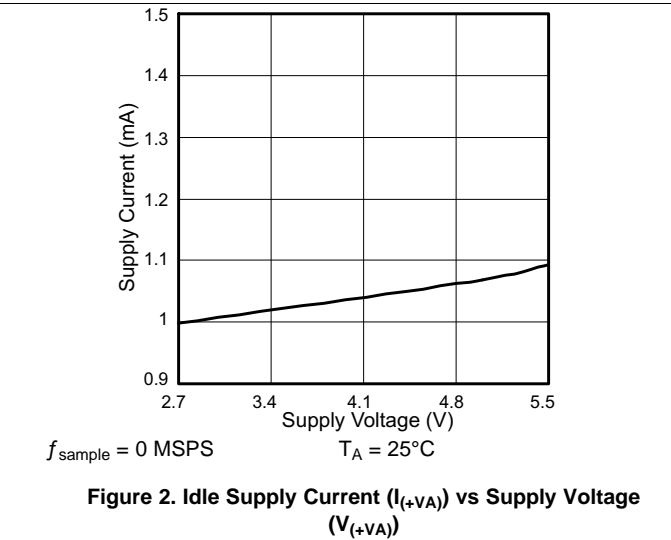
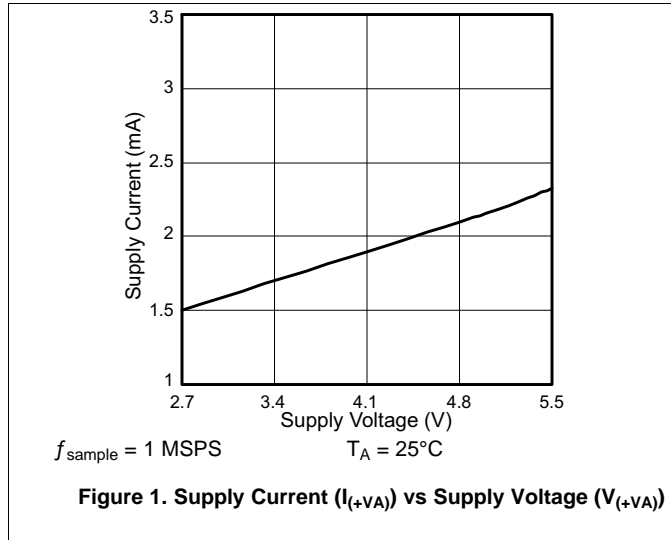

7.10 Typical Characteristics (12-Bit Devices Only)

Variations for 10-bit and 8-bit devices are too small to be illustrated through the characteristic curves.

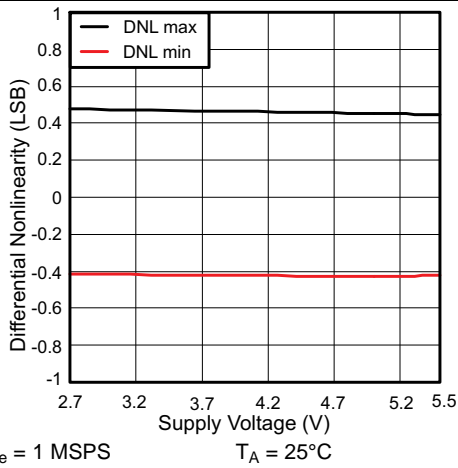

Figure 7. Differential Nonlinearity vs Supply Voltage ($V_{(+VA)}$)

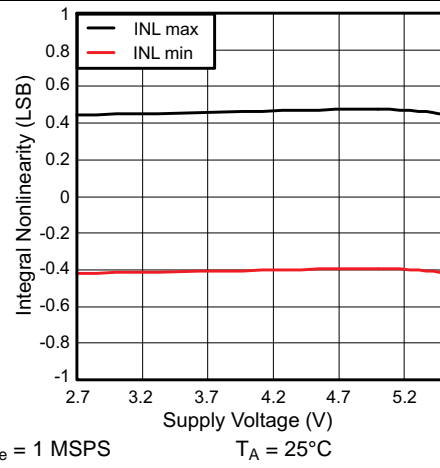

Figure 8. Integral Nonlinearity vs Supply Voltage ($V_{(+VA)}$)

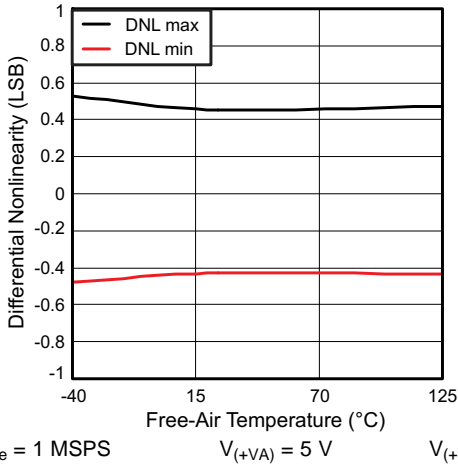

Figure 9. Differential Nonlinearity vs Free-Air Temperature

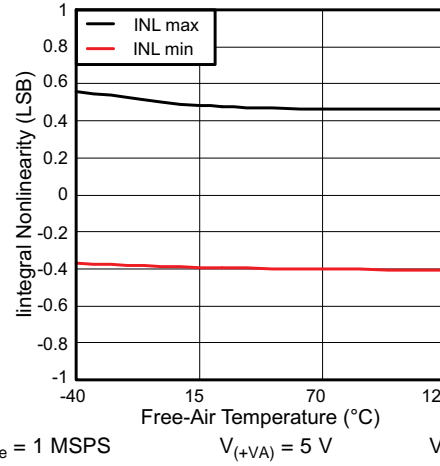

Figure 10. Integral Nonlinearity vs Free-Air Temperature

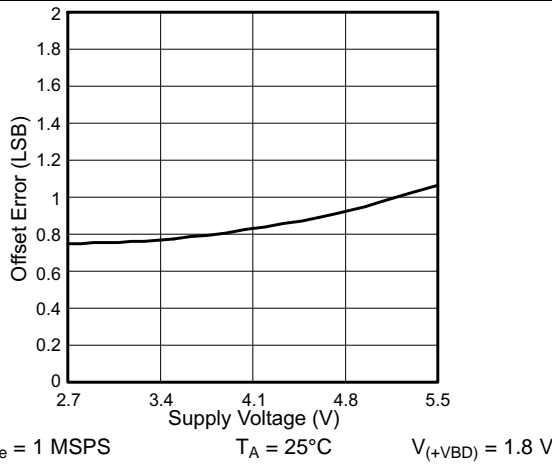

Figure 11. Offset Error vs Supply Voltage ($V_{(+VA)}$)

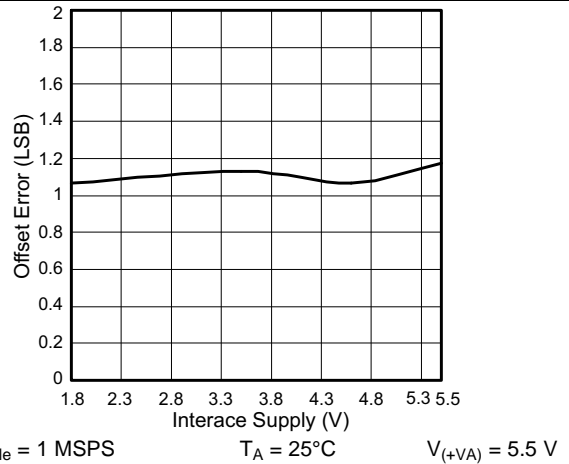
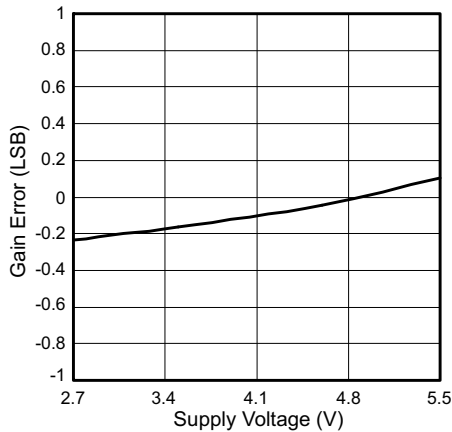

Figure 12. Offset Error vs Interface Supply Voltage ($V_{(+VBD)}$)

Typical Characteristics (12-Bit Devices Only) (continued)

Variations for 10-bit and 8-bit devices are too small to be illustrated through the characteristic curves.



$f_{\text{sample}} = 1 \text{ MSPS}$ $T_A = 25^\circ\text{C}$ $V_{(+VBD)} = 1.8 \text{ V}$

Figure 13. Gain Error vs Supply Voltage ($V_{(+VA)}$)

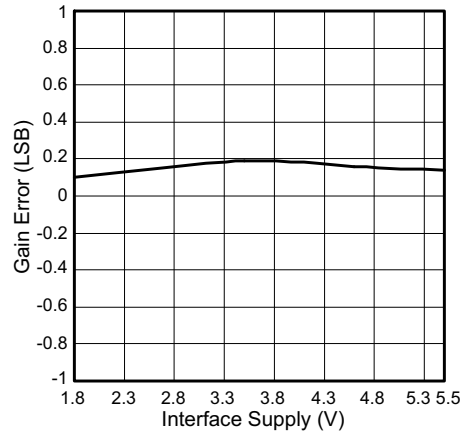

$f_{\text{sample}} = 1 \text{ MSPS}$ $T_A = 25^\circ\text{C}$ $V_{(+VA)} = 5.5 \text{ V}$

Figure 14. Gain Error vs Interface Supply Voltage ($V_{(+VBD)}$)

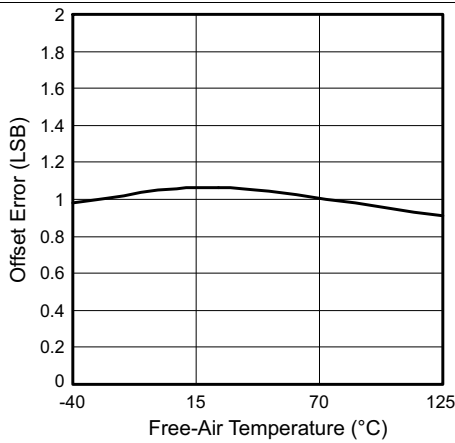

$f_{\text{sample}} = 1 \text{ MSPS}$ $V_{(+VA)} = 5.5 \text{ V}$ $V_{(+VBD)} = 1.8 \text{ V}$

Figure 15. Offset Error vs Free-Air Temperature

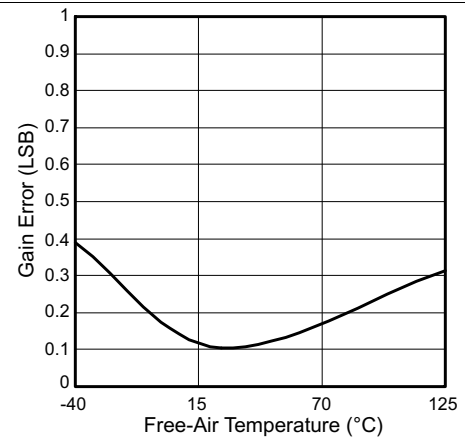

$f_{\text{sample}} = 1 \text{ MSPS}$ $V_{(+VA)} = 5.5 \text{ V}$ $V_{(+VBD)} = 1.8 \text{ V}$

Figure 16. Gain Error vs Free-Air Temperature

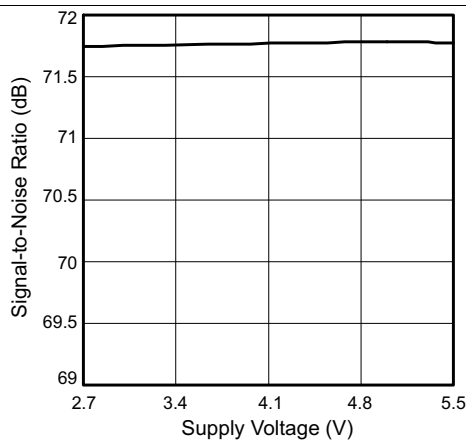

$f_{\text{sample}} = 1 \text{ MSPS}$ $T_A = 25^\circ\text{C}$ $V_{(+VBD)} = 3 \text{ V}$
 $f_{\text{input}} = 100 \text{ kHz}$

Figure 17. Signal-to-Noise Ratio vs Supply Voltage (+VA)

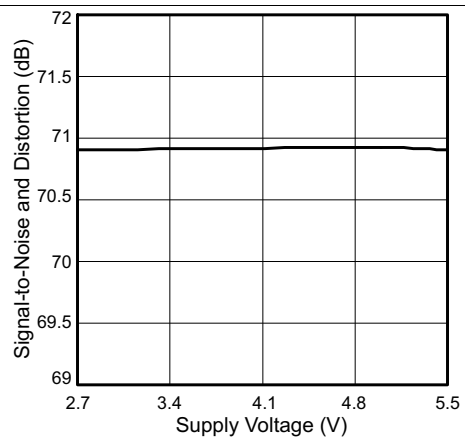

$f_{\text{sample}} = 1 \text{ MSPS}$ $T_A = 25^\circ\text{C}$ $V_{(+VBD)} = 3 \text{ V}$
 $f_{\text{input}} = 100 \text{ kHz}$

Figure 18. Signal-to-Noise With Distortion vs Supply Voltage ($V_{(+VA)}$)

Typical Characteristics (12-Bit Devices Only) (continued)

Variations for 10-bit and 8-bit devices are too small to be illustrated through the characteristic curves.

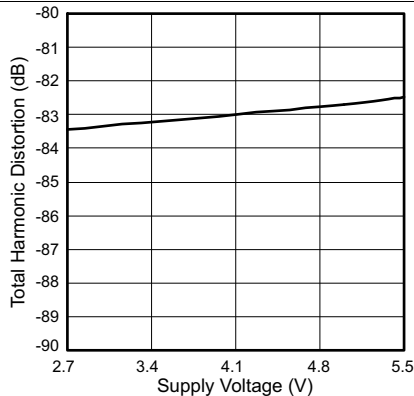

$f_{\text{sample}} = 1 \text{ MSPS}$ $T_A = 25^\circ\text{C}$ $V_{(+VBD)} = 3 \text{ V}$
 $f_{\text{input}} = 100 \text{ kHz}$

Figure 19. Total Harmonic Distortion (THD) vs Supply Voltage ($V_{(+VA)}$)

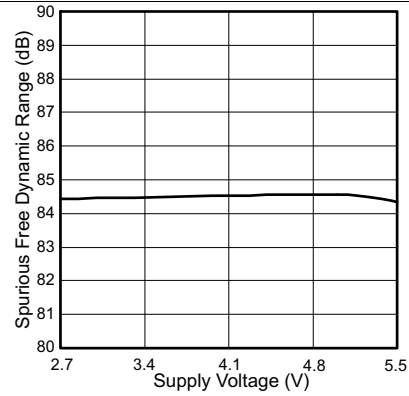

$f_{\text{sample}} = 1 \text{ MSPS}$ $T_A = 25^\circ\text{C}$ $V_{(+VBD)} = 3 \text{ V}$
 $f_{\text{input}} = 100 \text{ kHz}$

Figure 20. Spurious-Free Dynamic Range (SFDR) vs Supply Voltage ($V_{(+VA)}$)

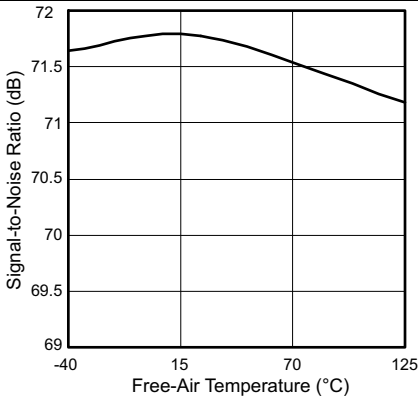

$f_{\text{sample}} = 1 \text{ MSPS}$ $V_{(+VA)} = 5 \text{ V}$ $V_{(+VBD)} = 3 \text{ V}$
 $f_{\text{input}} = 100 \text{ kHz}$

Figure 21. Signal-to-Noise Ratio vs Free-Air Temperature

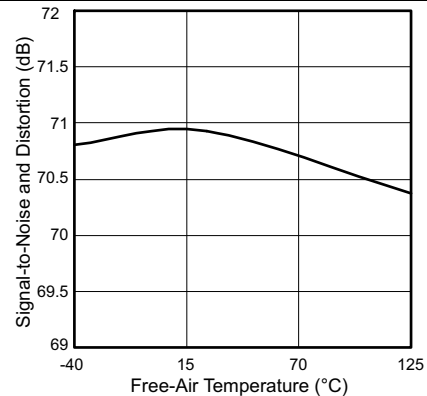

$f_{\text{sample}} = 1 \text{ MSPS}$ $V_{(+VA)} = 5 \text{ V}$ $V_{(+VBD)} = 3 \text{ V}$
 $f_{\text{input}} = 100 \text{ kHz}$

Figure 22. Signal-to-Noise With Distortion vs Free-Air Temperature

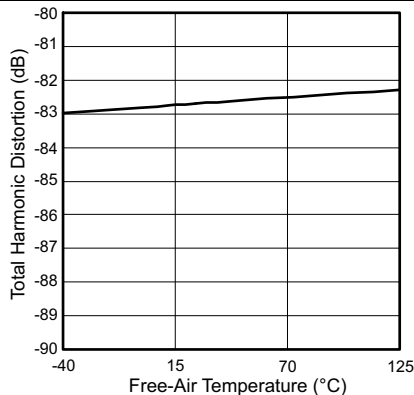

$f_{\text{sample}} = 1 \text{ MSPS}$ $V_{(+VA)} = 5 \text{ V}$ $V_{(+VBD)} = 3 \text{ V}$
 $f_{\text{input}} = 100 \text{ kHz}$

Figure 23. Total Harmonic Distortion vs Free-Air Temperature

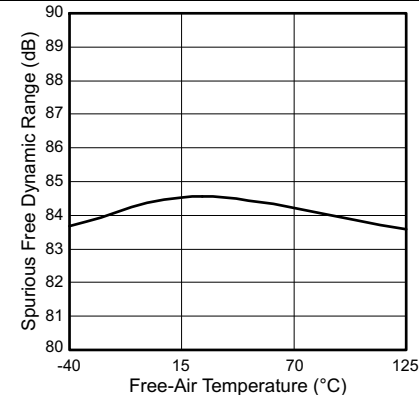

$f_{\text{sample}} = 1 \text{ MSPS}$ $V_{(+VA)} = 5 \text{ V}$ $V_{(+VBD)} = 3 \text{ V}$
 $f_{\text{input}} = 100 \text{ kHz}$

Figure 24. Spurious-Free Dynamic Range vs Free-air Temperature

Typical Characteristics (12-Bit Devices Only) (continued)

Variations for 10-bit and 8-bit devices are too small to be illustrated through the characteristic curves.

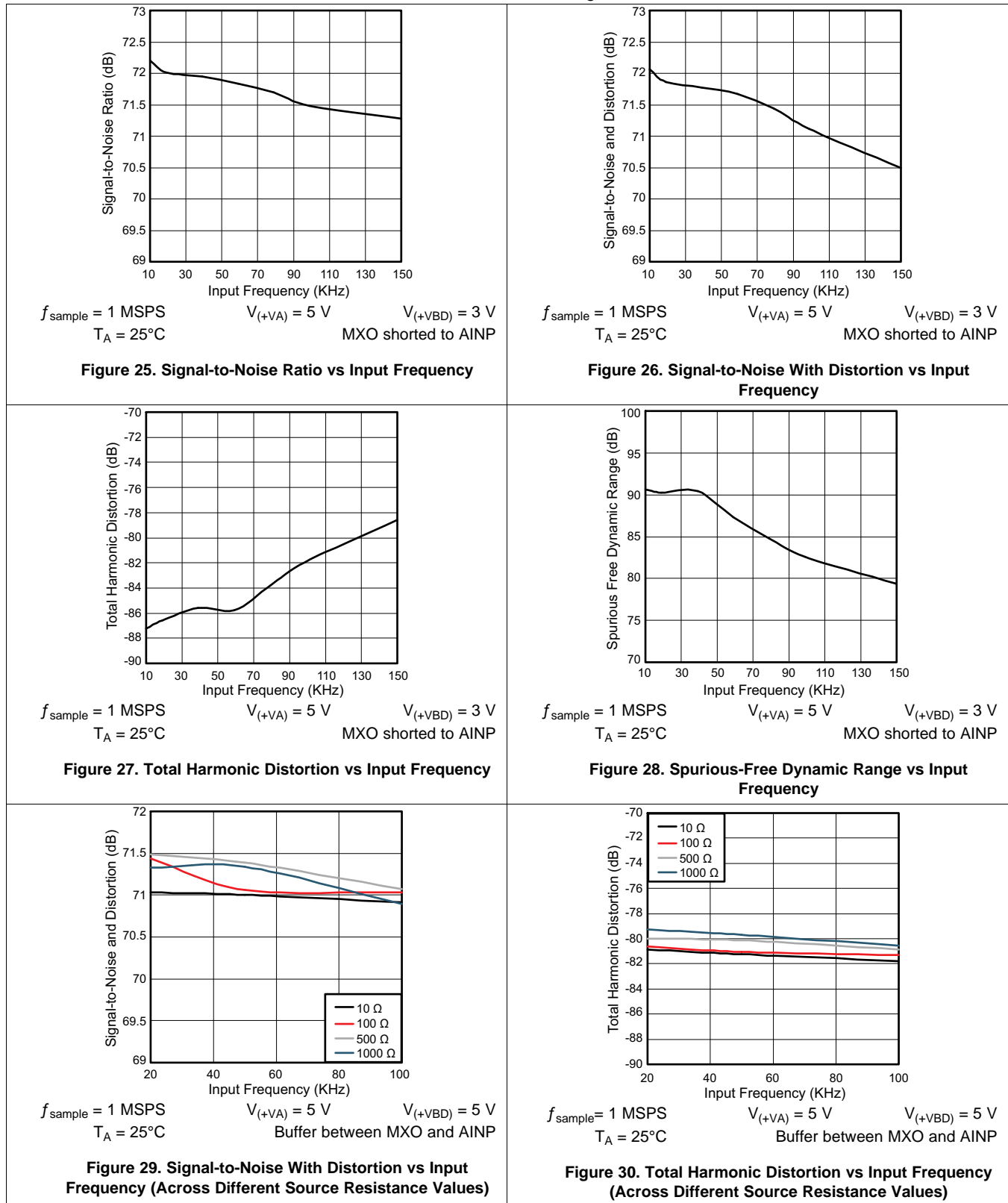

Typical Characteristics (12-Bit Devices Only) (continued)

Variations for 10-bit and 8-bit devices are too small to be illustrated through the characteristic curves.

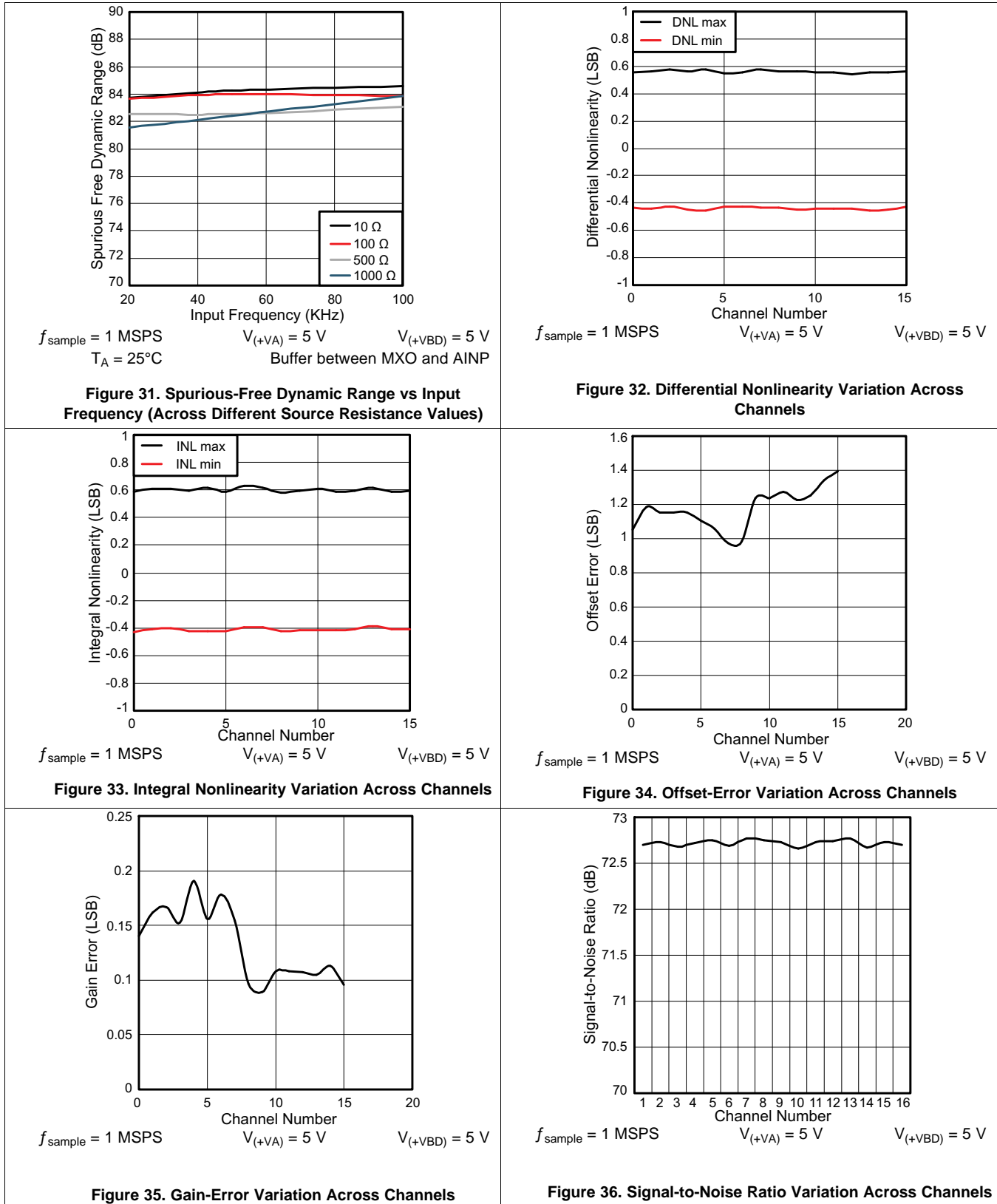

Typical Characteristics (12-Bit Devices Only) (continued)

Variations for 10-bit and 8-bit devices are too small to be illustrated through the characteristic curves.

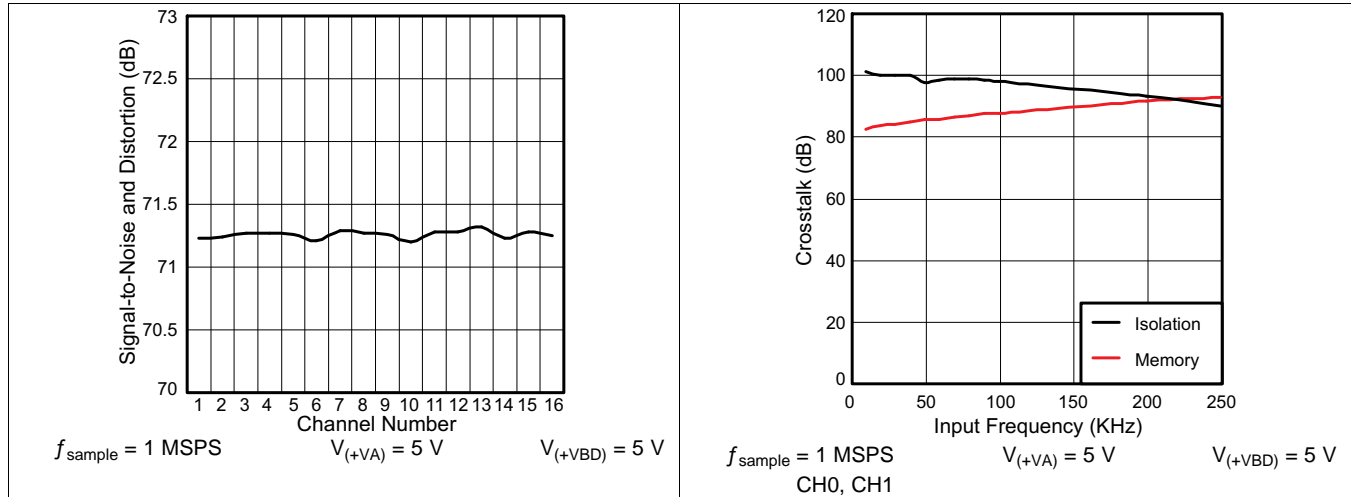

Figure 37. Signal-to-Noise With Distortion Variation Across Channels

Figure 38. Crosstalk vs Input Frequency

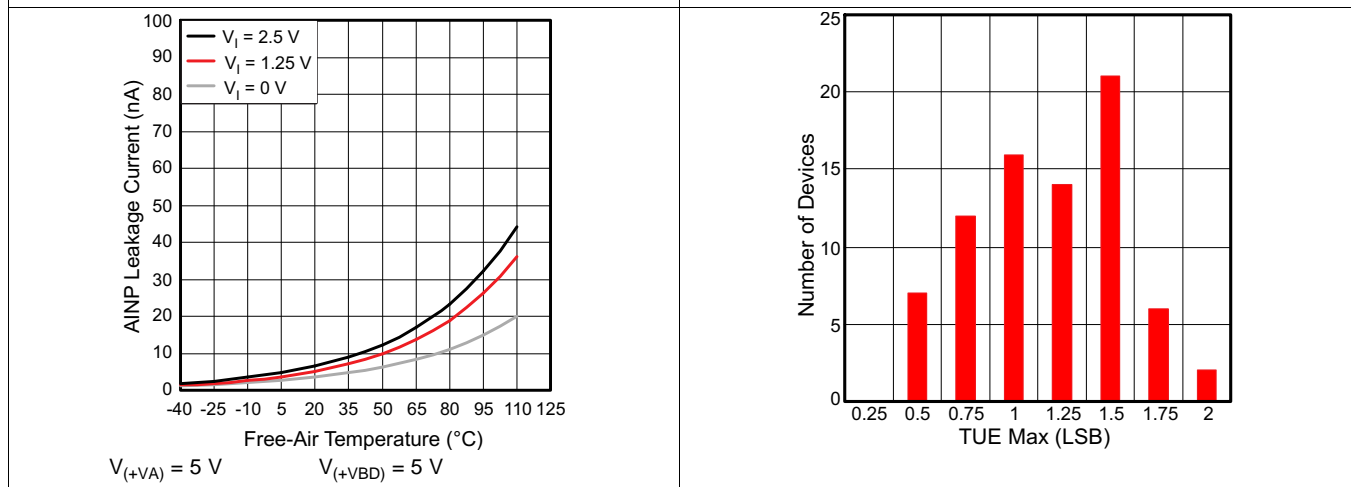

Figure 39. Input Leakage Current vs Free-Air Temperature

Figure 40. Total Unadjusted Error (TUE) Maximum

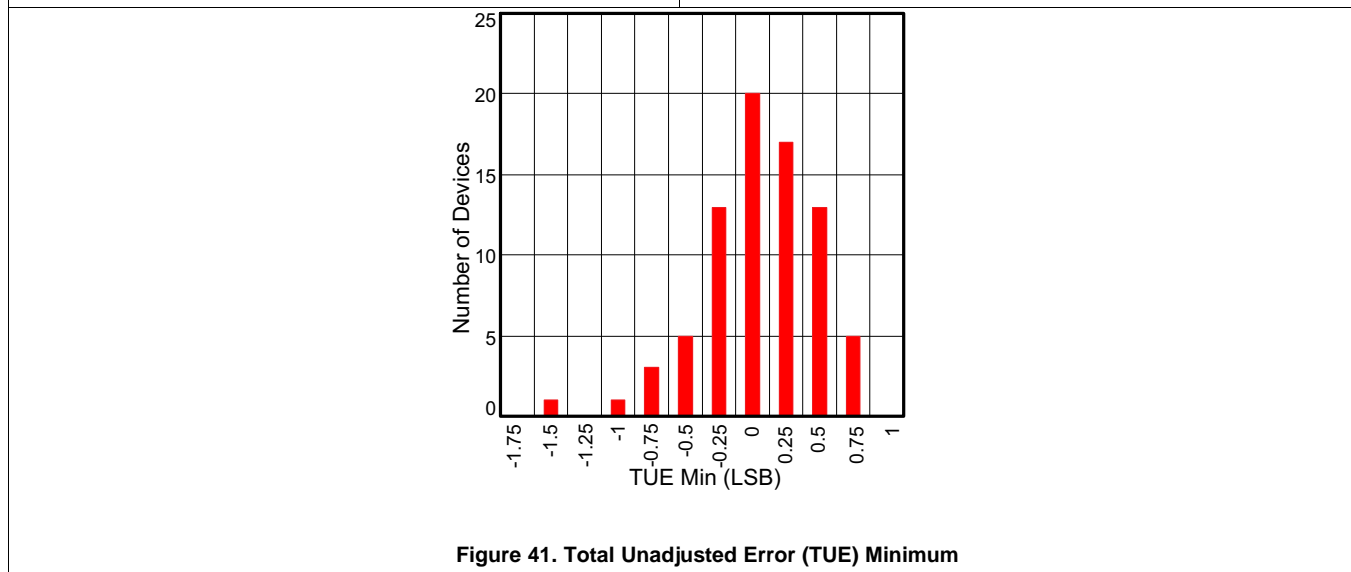
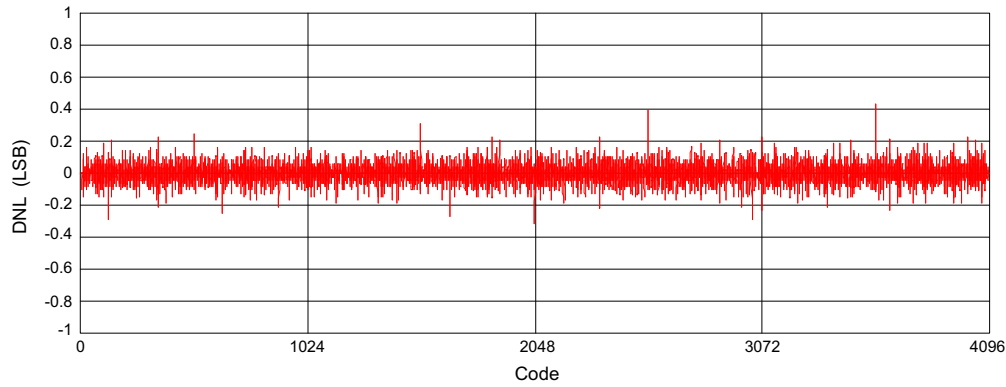
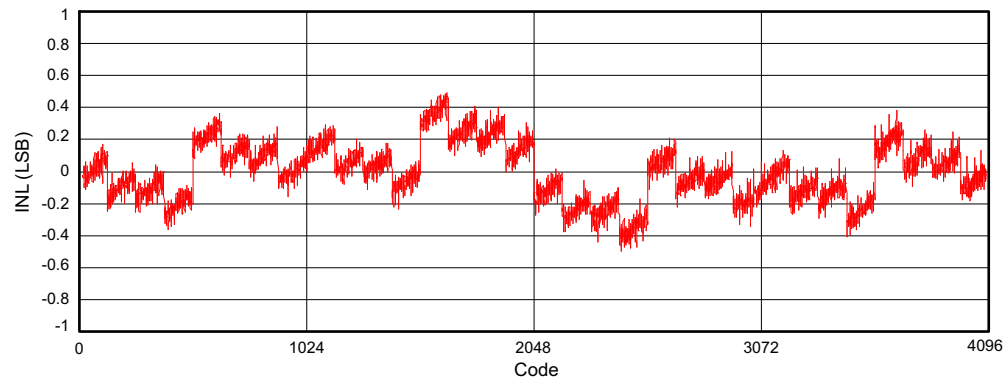

Figure 41. Total Unadjusted Error (TUE) Minimum



$f_{\text{sample}} = 1 \text{ MSPS}$ $V_{(+VA)} = 5 \text{ V}$ $V_{(+VBD)} = 5 \text{ V}$
 $T_A = 25^\circ\text{C}$

Figure 42. Differential Linearity (DNL) Error



$f_{\text{sample}} = 1 \text{ MSPS}$ $V_{(+VA)} = 5 \text{ V}$ $V_{(+VBD)} = 5 \text{ V}$

Figure 43. Integral Linearity (INL) Error

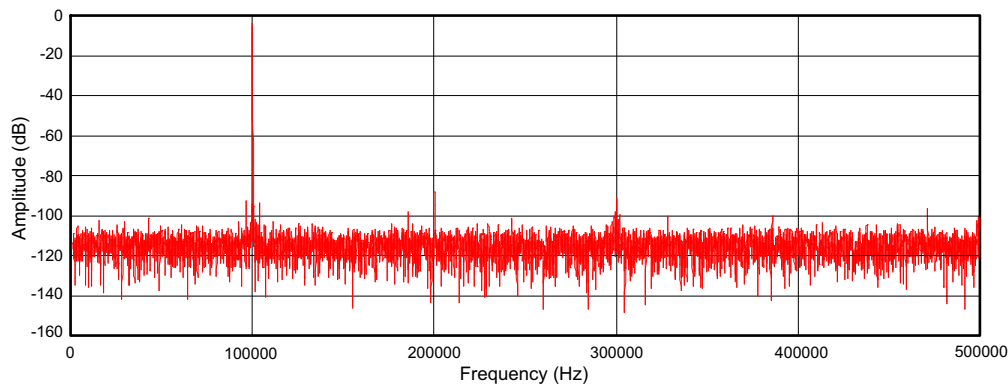

$f_{\text{sample}} = 1 \text{ MSPS}$ $V_{(+VA)} = 5 \text{ V}$ $V_{(+VBD)} = 5 \text{ V}$
 $f_{\text{input}} = 100 \text{ kHz}$ Npoints = 16,384

Figure 44. Power Spectrum

8 Detailed Description

8.1 Overview

The ADS79xx-Q1 device is a high-speed, low-power analog-to-digital converter (ADC) with an 8-bit, 10-bit, and 12-bit multichannel successive-approximation register (SAR). The architecture of the device is based on charge redistribution, which includes a sample and hold function. The ADS79xx-Q1 device uses an external reference and an external serial clock (SCLK) to run the conversion.

The analog input is provided to the CH_n input channel. The output of the multiplexer can be shorted directly or can be connected through a buffer to the AINP pin. Because the AINM pin is shorted to AGND, when a conversion is initiated, the differential input between the AINP and AGND pins is sampled on the internal capacitor array. Two input ranges are supported. Users can program the input range to either 0 V to V_{ref} or 0 V to $2 \times V_{ref}$ using the mode-control register. The same register can program the input channel sequencing.

The ADS79xx-Q1 device also has four general-purpose input and output (GPIO) pins that can be programmed independently as either general-purpose output (GPO) or general-purpose Input (GPI) pins. GPIOs also support alarm function for which high and low thresholds are programmable per channel.

8.2 Functional Block Diagram

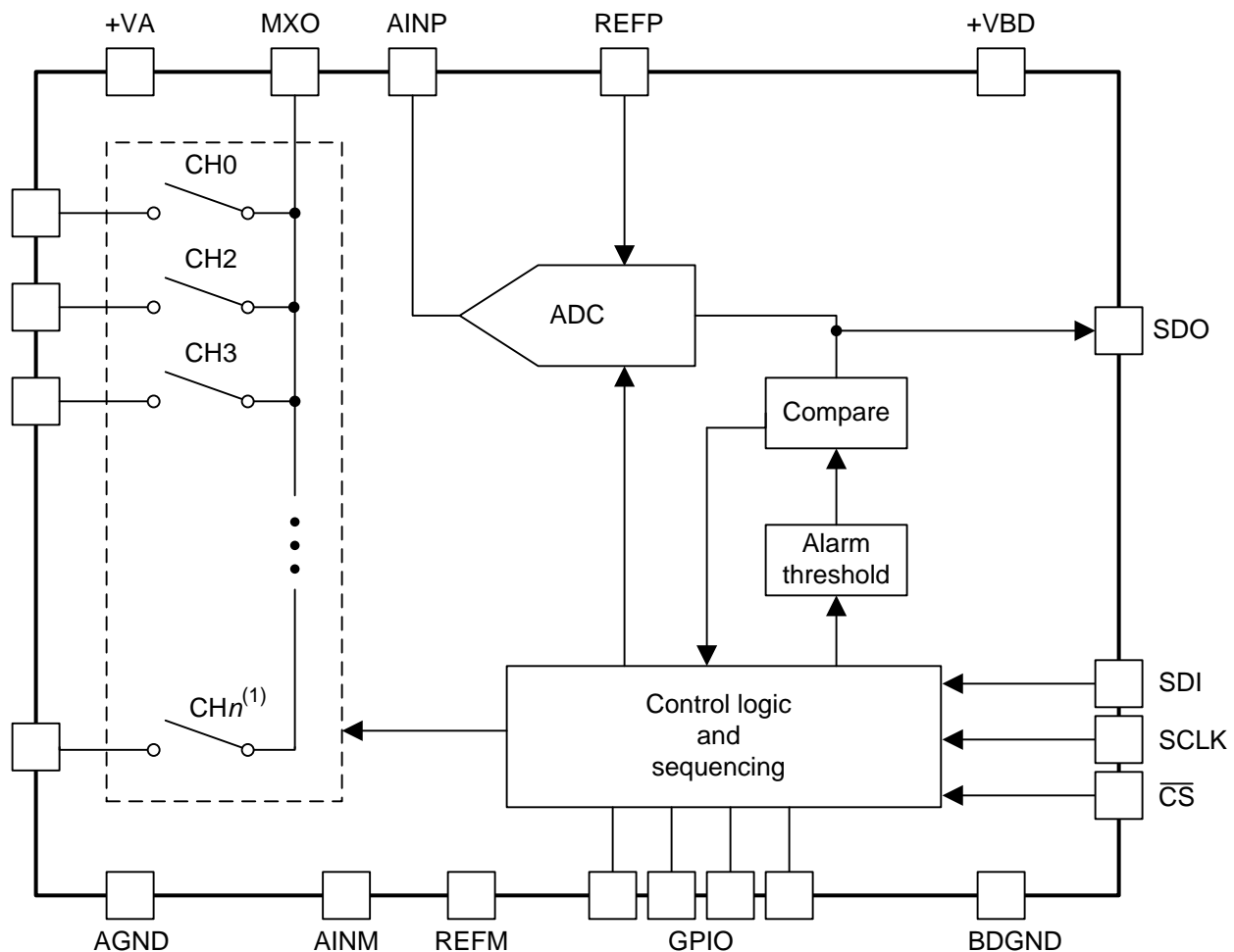

(1) *n* is number of channels (4, 8, 12, or 16) depending on the device from the ADS79xx-Q1 device family.

8.3 Feature Description

8.3.1 Device Operation

Figure 45, Figure 46, Figure 47, and Figure 48 illustrate device operation timing. Device operation is controlled with the \overline{CS} , SCLK, and SDI pins. The device outputs data on the SDO pin.

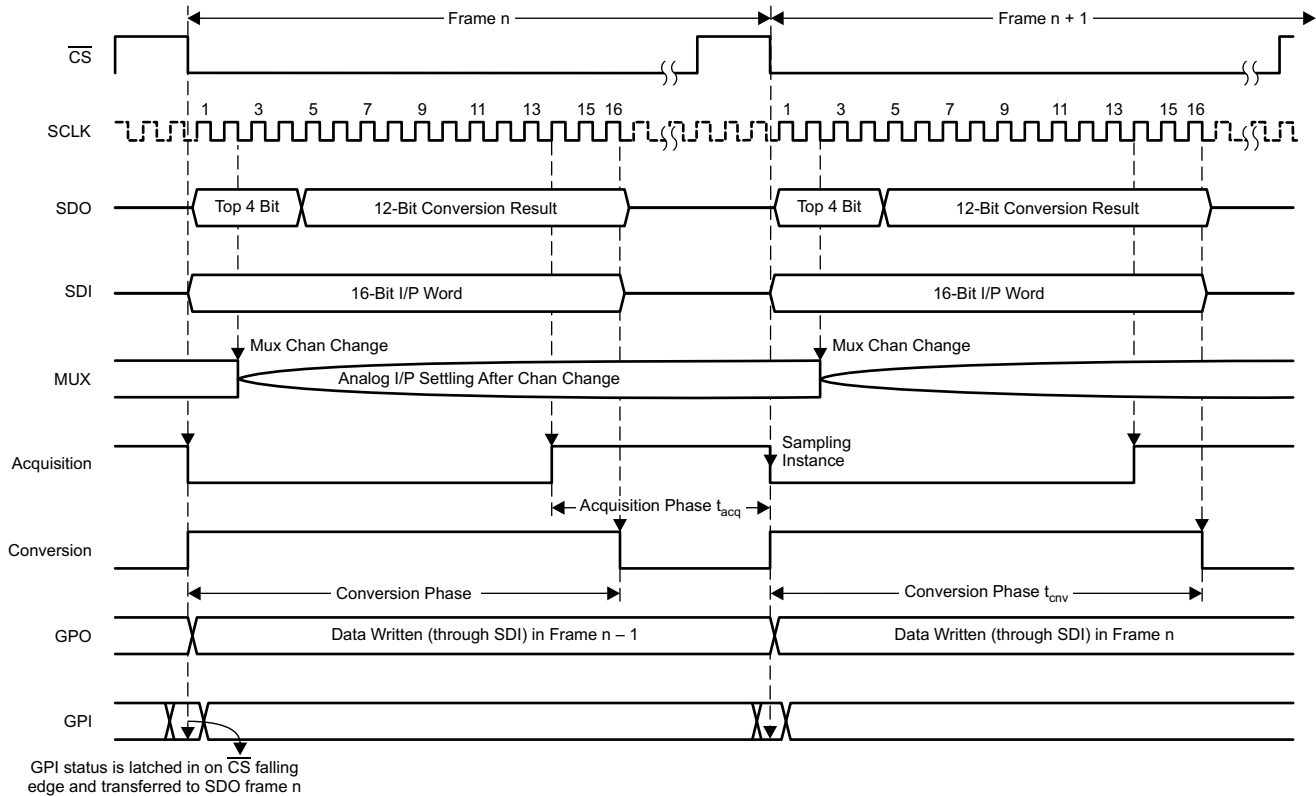

Figure 45. Device Operation Timing Diagram

Each frame begins with the falling edge of the \overline{CS} pin. With the falling edge of the \overline{CS} pin, the input signal from the selected channel is sampled, and the conversion process is initiated. The device outputs data while the conversion is in progress. The 16-bit data word contains a 4-bit channel address, followed by a 12-bit conversion result in most-significant-bit (MSB) first format. The GPIO status can be read instead of the channel address (see Table 1, Table 2, and Table 5).

The device selects a new multiplexer channel on the second SCLK falling edge. The acquisition phase begins on the 14th SCLK rising edge. On the next \overline{CS} falling edge the acquisition phase ends, and the device starts a new frame.

There are four general-purpose IO (GPIO) pins. These pins can be individually programmed as GPO or GPI. Using these pins for preassigned functions is also possible (see Table 11). GPO data can be written into the device through the SDI line. The device refreshes the GPO data on the \overline{CS} falling edge according to the SDI data written in previous frame.

Similarly the device latches the GPI status on the \overline{CS} falling edge and outputs the GPI data on the SDO line (if GPI read is enabled by writing DI04 = 1 in the previous frame) in the same frame starting with the \overline{CS} falling edge.

Feature Description (continued)

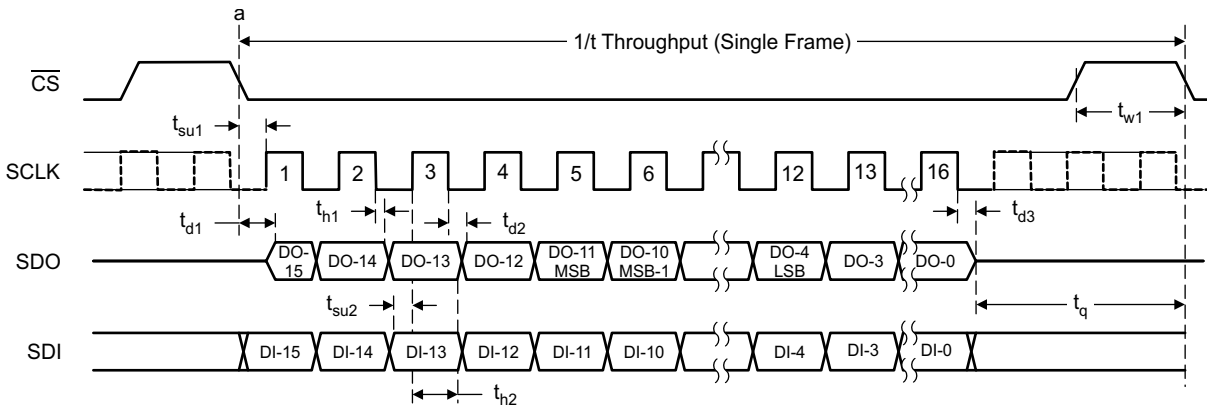

Figure 46. Serial Interface Timing Diagram for 8-Bit Devices (ADS7958, ADS7959, ADS7960, and ADS7961)

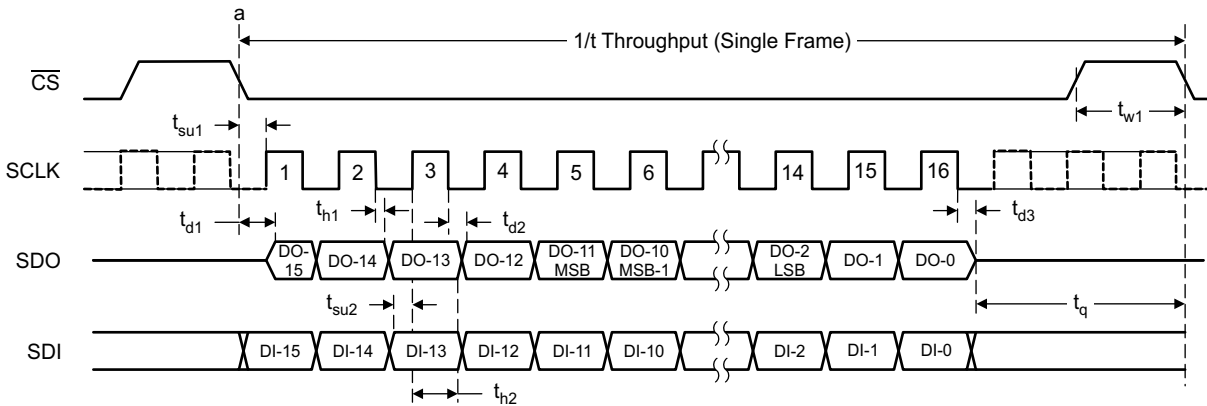

Figure 47. Serial Interface Timing Diagram for 10-Bit Devices (ADS7954, ADS7956, and ADS7957)

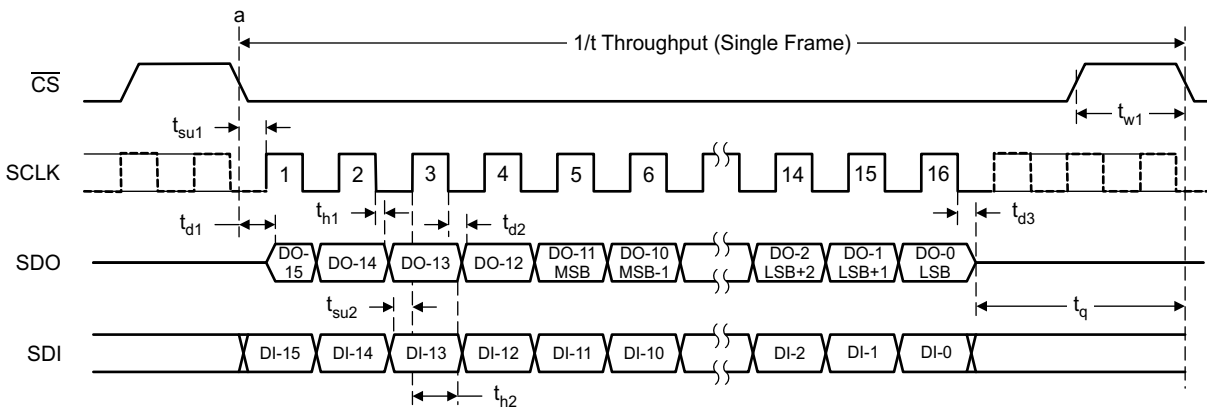

Figure 48. Serial Interface Timing Diagram for 12-Bit Devices (ADS7950, ADS7951, ADS7952, and ADS7953)

Feature Description (continued)

The falling edge of the \overline{CS} pin clocks out the DO-15 bit (the first bit of the four bit channel address), and remaining address bits are clocked out on every falling edge of SCLK until the third falling edge. The conversion result MSB is clocked out on the fourth SCLK falling edge and LSB on the 11th, 13th, or 15th falling edge respectively for 8-bit, 10-bit, or 12-bit devices. On the 16th falling edge of the SCLK pin, the SDO pin enters tri-state condition. The conversion ends on the 16th falling edge of SCLK.

While the device outputs data on the SDO pin, a 16-bit word is read on the SDI pin. The SDI data are latched on every rising edge of the SCLK pin beginning with the first clock; see [Figure 46](#), [Figure 47](#), and [Figure 48](#).

The \overline{CS} pin can be asserted (pulled high) only after 16 clocks have elapsed.

The device has two (high and low) programmable alarm thresholds per channel. If the input crosses these limits the device flags out an alarm on the GPIO0 or GPIO1 pin depending on the GPIO-program register settings (see [Table 11](#)). The alarm is asserted (under the alarm conditions) on the 12th falling edge of the SCLK pin in the same frame when a data conversion is in progress. The alarm output is reset on the tenth falling edge of the SCLK pin in the next frame.

8.3.2 Device Power-up Sequence

[Figure 49](#) illustrates the device power-up sequence. Manual mode is the default power-up channel-sequencing mode and channel-0 is the first channel by default. As explained previously, these devices offer program registers to configure user-programmable features (such as GPIO, alarm, and to preprogram the channel sequence for the auto modes). At power up or on reset, these registers are set to the default values listed in [Table 1](#) to [Table 11](#). Program these registers on power up or after reset. When configured, the device is ready to use in any of the three channel sequencing modes: manual, auto-1, and auto-2.

Feature Description (continued)

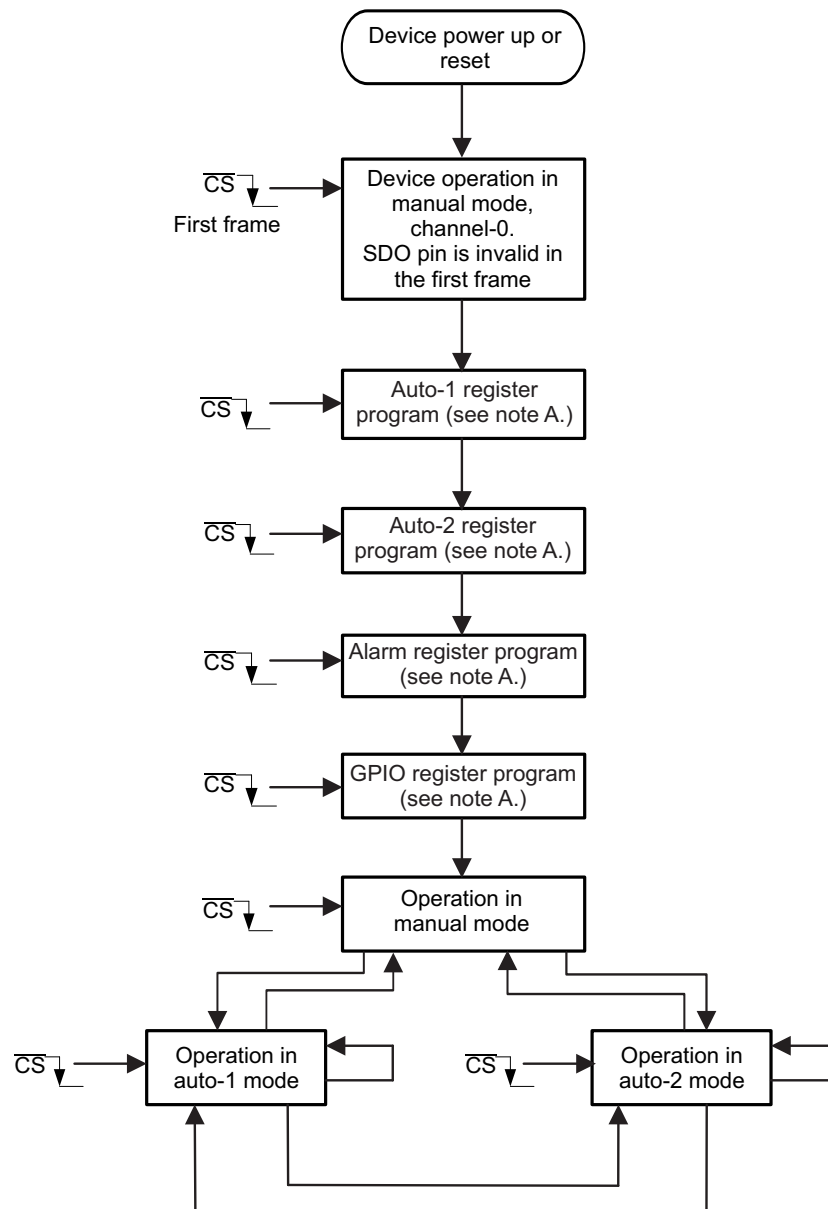

A. The device continues operation in manual-mode channel 0 throughout the programming sequence and outputs valid conversion results. Changing the channel, range, or GPIO is possible by inserting extra frames in between two programming blocks. Bypassing any programming block is also possible if that feature is not intended for use.

B. Reprogramming the device at any time during operation, regardless of what mode the device is in, is possible. During programming, the device continues operation in whatever mode it is in and outputs valid data.

Figure 49. Device Power-Up Sequence

Feature Description (continued)

8.3.3 Analog Input

The ADS79x-Q1 device family offers 8-bit, 10-bit, and 12-bit ADCs with 4-channel, 8-channel, 12-channel, 16-channel multiplexers for analog input. The multiplexer output is available on the MXO pin. The AINP pin is the ADC input pin. The device offers flexibility for a system designer as both MXO and AINP are accessible externally.

Figure 50 shows the equivalent circuit at the input and output of the multiplexer and the input of the converter during sampling. When the converter enters hold mode, the input impedance at AINP is greater than 1 GΩ.

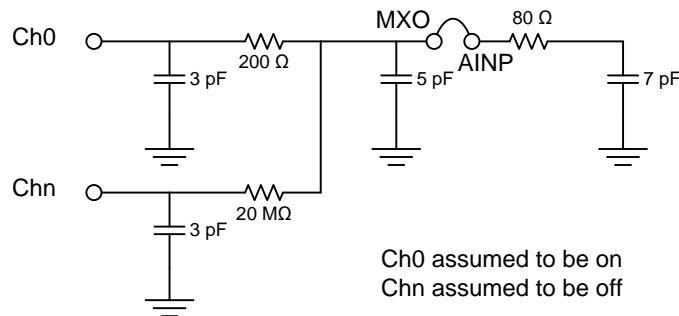

Figure 50. ADC and MUX Equivalent Circuit

When the converter samples an input, the voltage difference between the AINP and AGND pins is captured on the internal capacitor array. The peak input current through the analog inputs depends upon a number of factors including sample rate, input voltage, and source impedance. The current into the ADS79xx-Q1 device charges the internal capacitor array during the sample period. After this capacitance is fully charged, there is no further input current.

To maintain the linearity of the converter, the Ch0 through Chn and AINP inputs must be within the input range limits specified. Outside of these ranges, converter linearity may not meet specifications.

8.3.4 Reference

The ADS79xx-Q1 device can operate with an external 2.5-V \pm 10-mV reference. A clean, low-noise, well-decoupled reference voltage on the REF pin is required to ensure good performance from the converter. A low-noise, band-gap reference (such as the REF5025 device) can be used to drive this pin. A 10- μ F ceramic decoupling capacitor is required between the REF and GND pins of the converter. Place the capacitor as close as possible to the device pins.

8.3.5 Power Saving

The ADS79xx-Q1 device offers a power-down feature to save power when not in use. There are two ways to power down the device. The device can be powered down by writing the DI05 bit equal to 1 in the mode control register (see Table 1, Table 2, and Table 5). In this case, the device powers down on the 16th falling edge of the SCLK pin in the next data frame. Another way to power down the device is through the GPIO pins. The GPIO3 pin can act as a $\overline{\text{PD}}$ input (see Table 11 for assigning this functionality to the GPIO3 pin) which is an asynchronous and active-low input. The device powers down instantaneously after the GPIO3 pin ($\overline{\text{PD}}$) equals 0. The device powers up again on the $\overline{\text{CS}}$ falling edge when the DI05 bit equals 0 in the mode control register, and the GPIO3 pin (PD) equals 1.

8.4 Device Functional Modes

8.4.1 Channel Sequencing Modes

There are three modes for channel sequencing, including *manual mode*, *auto-1 mode*, and *auto-2 mode*. Mode selection occurs by writing into the *control register* (see Table 1, Table 2, and Table 5). A new multiplexer channel is selected on the second falling edge of SCLK (as shown in Figure 45) in all three modes.

Device Functional Modes (continued)

Manual mode: When configured to operate in manual mode, the next selected channel is programmed in each frame and the device selects the programmed channel in the next frame. On power up or after reset the default channel is channel-0 and the device is in manual mode.

Auto-1 mode: In this mode the device scans pre-programmed channels in ascending order. A new multiplexer channel is selected every frame on the second falling edge of the SCLK pin. A separate program register preprograms the channel sequence. [Table 3](#) and [Table 4](#) show auto-1 program register settings.

When programmed, the device retains the program register settings until the device is powered down, reset, or reprogrammed. The device is allowed to exit and reenter the auto-1 mode any number of times without disturbing the program register settings.

The auto-1 program register is reset to F, FF, FFF, or FFFF (hex) for the 4-channel, 8-channel, 12-channel, or 16-channel devices, respectively, upon device power up or reset (implying the device scans all channels in ascending order).

Auto-2 mode: In this mode the user can configure the program register to select the last channel in the scan sequence. The device scans all channels from channel-0 up to, and including, the last channel in ascending order. The multiplexer channel is selected every frame on the second falling edge of the SCLK pin. A separate program register preprograms the last channel in the sequence (multiplexer depth). [Table 6](#) lists the auto-2 program register settings for selection of the last channel in the sequence.

When programmed, the device retains the program register settings until the device is powered down, reset, or reprogrammed. The device is allowed to exit and re-enter auto-2 mode any number of times, without disturbing the program register settings.

On power up or reset, bits D9 to D6 of the auto-2 program register are reset to 3, 7, B, or F (hex) 4-channel, 8-channel, 12-channel or 16-channel devices, respectively (implying the device scans all channels in ascending order).

8.4.2 Device Programming and Mode Control

The following sections describe device programming and mode control. The ADS79xx-Q1 device feature two types of registers to configure and operate the devices in different modes. These registers are referred as configuration registers. The two types of configuration registers are mode control registers and program registers.

8.4.2.1 Mode Control Register

A mode control register is configured to operate the device in one of three channel sequencing modes, either manual mode, auto-1 mode, or auto-2 mode. This register is also used to control user programmable features, such as range selection, device power-down control, GPIO read control, and writing output data into the GPIO pins.

8.4.2.2 Program Registers

The program registers are used for device-configuration settings and are typically programmed once on power up or after device reset. There are different program registers including auto-1 mode programming for preprogramming the channel sequence, auto-2 mode programming for selection of the last channel in the sequence, alarm programming for all 16 channels (or 4, 8, or 12 channels depending on the device), and GPIO for individual pin configuration, such as GPI or GPO or a preassigned function.

8.4.3 Operating In Manual Mode

[Figure 51](#) illustrates details regarding entering and running in manual channel-sequencing mode. [Table 1](#) lists the mode control register settings for manual mode in detail. Note that there are no program registers for manual mode.

Device Functional Modes (continued)

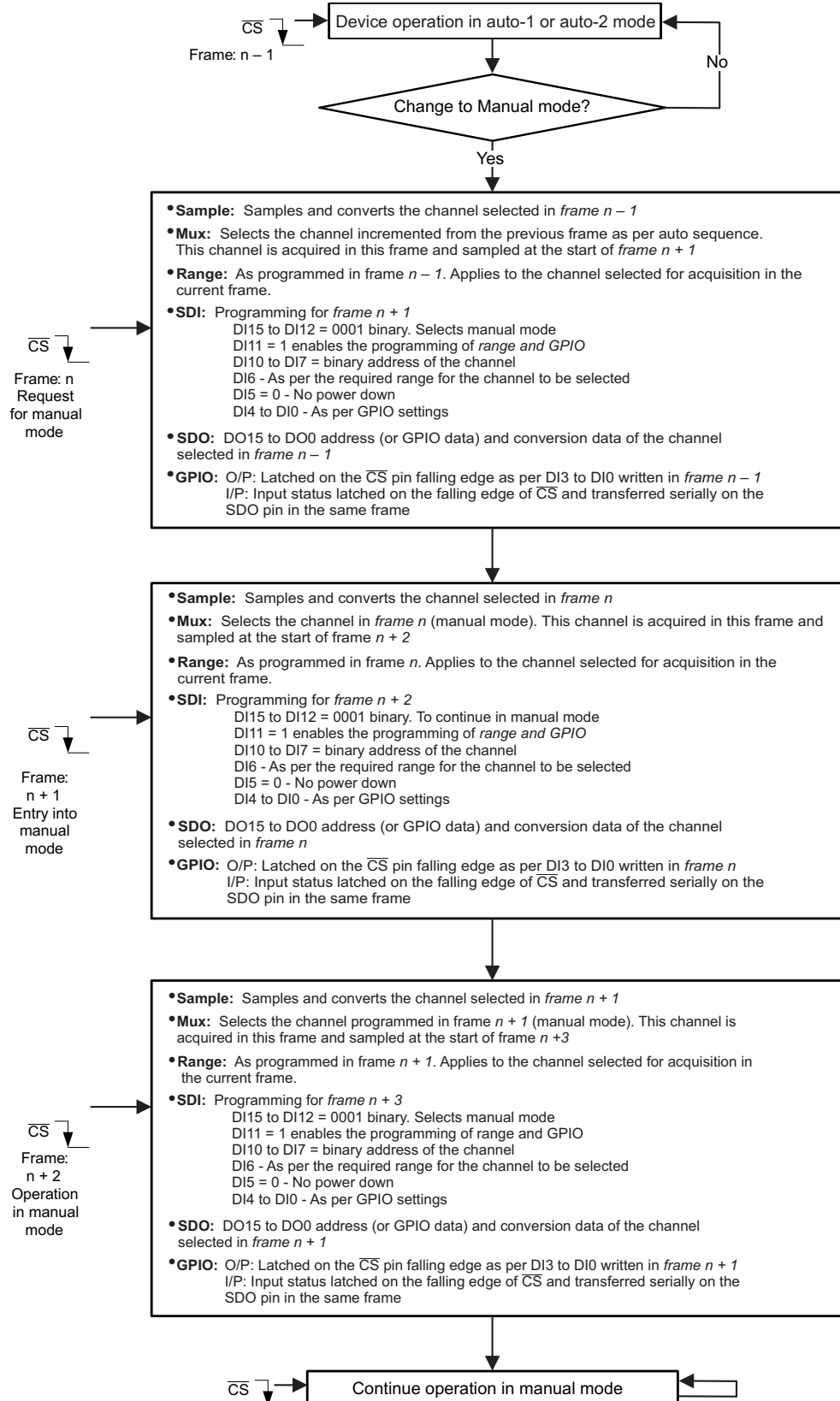

Figure 51. Entering and Running in Manual Channel-Sequencing Mode

Device Functional Modes (continued)

Table 1. Mode-Control Register Settings for Manual Mode

BITS	RESET STATE	DESCRIPTION			
		LOGIC STATE	FUNCTION		
DI15-12	0001	0001	Selects manual mode		
DI11	0	1	Enables programming of bits DI06 through DI00		
		0	Device retains values of bits DI06 through DI00 from the previous frame		
DI10-07	0000	This 4-bit data represents the address of the next channel to be selected in the next frame. DI10 = MSB and DI07 = LSB. For example, 0000 represents channel-0, 0001 represents channel-1, and so on.			
DI06	0	0	Selects 2.5-V input range (range 1)		
		1	Selects 5-V input range (range 2)		
DI05	0	0	Device normal operation (no power down)		
		1	Device powers down on 16th SCLK falling edge		
DI04	0	0	The SDO pin outputs the current channel address of the channel on bits DO15 through DO12 followed by a 12-bit conversion result on bits DO11 through DI00.		
			1	The GPIO3 through GPIO0 data (both input and output) is mapped onto bits DO15 through DO12 in the order shown below. Lower data bits DO11 through DO00 represent the 12-bit conversion result of the current channel.	
		DO15		DO14	DO13
		GPIO3	GPIO2	GPIO1	GPIO0
DI03-00	0000	The GPIO data for the channels configured as an output. The device ignores the data for the channel which is configured as input. The SDI bit and corresponding GPIO information is given below.			
		DI03	DI02	DI01	DI00
		GPIO3	GPIO2	GPIO1	GPIO0

8.4.4 Operating In Auto-1 Mode

Figure 52 shows a flowchart containing the details regarding entering and running in auto-1 channel-sequencing mode. Table 2 lists the mode control register settings for auto-1 mode in detail.

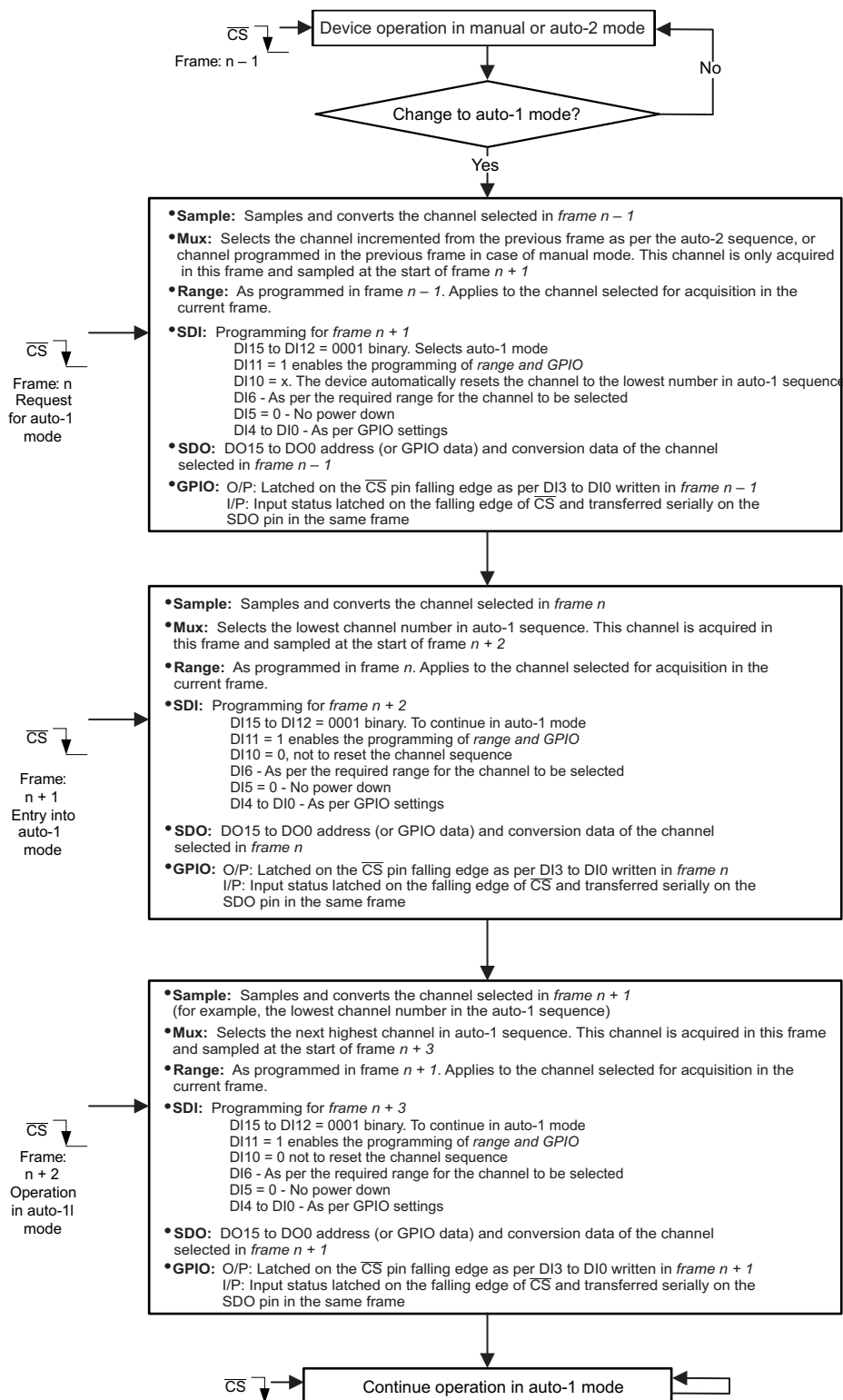
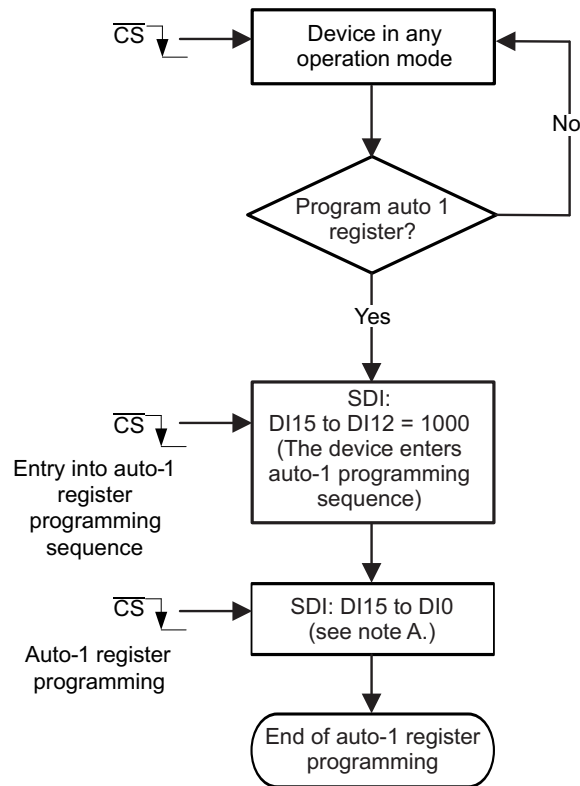

Figure 52. Entering and Running in Auto-1 Channel-Sequencing Mode

Table 2. Mode-Control Register Settings for Auto-1 Mode

BITS	RESET STATE	DESCRIPTION			
		LOGIC STATE	FUNCTION		
DI15-12	0001	0010	Selects auto-1 mode		
DI11	0	1	Enables programming of bits DI10 through DI00		
		0	Device retains values of bits DI10 through DI00 from previous frame		
DI10	0	1	The channel counter is reset to the lowest programmed channel in the auto-1 program register		
		0	The channel counter increments every conversion (no reset)		
DI09-07	000	xxx	Do not care		
DI06	0	0	Selects 2.5-V input range (range 1)		
		1	Selects 5-V input range (range 2)		
DI05	0	0	Device normal operation (no powerdown)		
		1	Device powers down on the 16th SCLK falling edge		
DI04	0	0	SDO outputs current channel address of the channel on DO15..12 followed by 12-bit conversion result on DO11 through DO00.		
		1	The GPIO3 to GPIO0 data (both input and output) is mapped onto DO15 through DO12 in the order shown below. Lower data bits DO11 through DO00 represent the 12-bit conversion result of the current channel.		
			DO15	DO14	DO13
		GPIO3	GPIO2	GPIO1	GPIO0
DI03-00	0000	The GPIO data for the channels configured as an output. The device ignores the data for the channel which is configured as input. The SDI bit and corresponding GPIO information is given below			
		DI03	DI02	DI01	DI00
		GPIO3	GPIO2	GPIO1	GPIO0

The auto-1 program register is programmed (once on power up or reset) to preselect the channels for the auto-1 sequence, as shown in [Figure 53](#). The auto-1 program-register programming requires two CS frames for complete programming. In the first CS frame, the device enters the auto-1 register programming sequence, and in the second frame the device programs the auto-1 program register. For complete details see [Table 2](#), [Table 3](#), and [Table 4](#).



A. Per [Table 3](#) and [Table 4](#).

B. The device continues operation in the selected mode during programming. The SDO pin is valid, however changing the range or writing the GPIO data into the device during programming is not possible.

Figure 53. Auto-1 Register Programming Flowchart

Table 3. Program Register Settings for Auto-1 Mode

BITS	RESET STATE	DESCRIPTION	
		LOGIC STATE	FUNCTION
FRAME 1			
DI15-12	NA	1000	The device enters auto-1 program sequence. Device programming occurs in the next frame.
DI11-00	NA	Do not care	
FRAME 2			
DI15-00	All 1's	1 (individual bit)	A particular channel is programmed to be selected in the channel scanning sequence. The channel numbers are mapped one-to-one with respect to the SDI bits. For example, DI15 → Ch15, DI14 → Ch14 ... DI00 → Ch00
		0 (individual bit)	A particular channel is programmed to be skipped in the channel scanning sequence. The channel numbers are mapped one-to-one with respect to the SDI bits. For example, DI15 → Ch15, DI14 → Ch14 ... DI00 → Ch00

Table 4. Mapping of Channels to SDI Bits

DEVICE ⁽¹⁾	SDI BITS															
	DI15	DI14	DI13	DI12	DI11	DI10	DI09	DI08	DI07	DI06	DI05	DI04	DI03	DI02	DI01	DI00
4 Channel	X	X	X	X	X	X	X	X	X	X	X	X	1/0	1/0	1/0	1/0
8 Channel	X	X	X	X	X	X	X	X	1/0	1/0	1/0	1/0	1/0	1/0	1/0	1/0
12 Channel	X	X	X	X	1/0	1/0	1/0	1/0	1/0	1/0	1/0	1/0	1/0	1/0	1/0	1/0
16 Channel	1/0	1/0	1/0	1/0	1/0	1/0	1/0	1/0	1/0	1/0	1/0	1/0	1/0	1/0	1/0	1/0

(1) When operating in auto-1 mode, the device only scans the channels programmed to be selected.

8.4.5 Operating In Auto-2 Mode

Figure 54 illustrates the details regarding entering and running in auto-2 channel-sequencing mode. Table 5 lists the mode-control register settings for auto-2 mode in detail.

Table 5. Mode-Control Register Settings for Auto-2 Mode

BITS	RESET STATE	DESCRIPTION				
		LOGIC STATE	FUNCTION			
DI15-12	0001	0011	Selects auto-2 mode			
DI11	0	1	Enables programming of bits DI10 through DI00			
		0	The device retains values of DI10 through DI00 from the previous frame			
DI10	0	1	The channel number is reset to Ch-00			
		0	The channel counter increments every conversion (no reset)			
DI09-07	000	xxx	Do not care			
DI06	0	0	Selects 2.5-V input range (range 1)			
		1	Selects 5-V input range (range 2)			
DI05	0	0	Device normal operation (no powerdown)			
		1	The device powers down on the 16th SCLK falling edge			
DI04	0	0	The SDO pin outputs the current channel address of the channel on bits DO15 through DO12 followed by the 12-bit conversion result on bits DO11 through DO00.			
			1	The GPIO3 to GPIO0 data (both input and output) is mapped onto bits DO15 through DO12 in the order shown below. Lower data bits DO11 through DO00 represent the 12-bit conversion result of the current channel.		
		DO15		DO14	DO13	DO12
		GPIO3		GPIO2	GPIO1	GPIO0
DI03-00	0000	The GPIO data for the channels configured as an output. The device ignores data for the channel that is configured as input. The SDI bit and corresponding GPIO information is given below.				
		DI03		DI02	DI01	DI00
		GPIO3		GPIO2	GPIO1	GPIO0

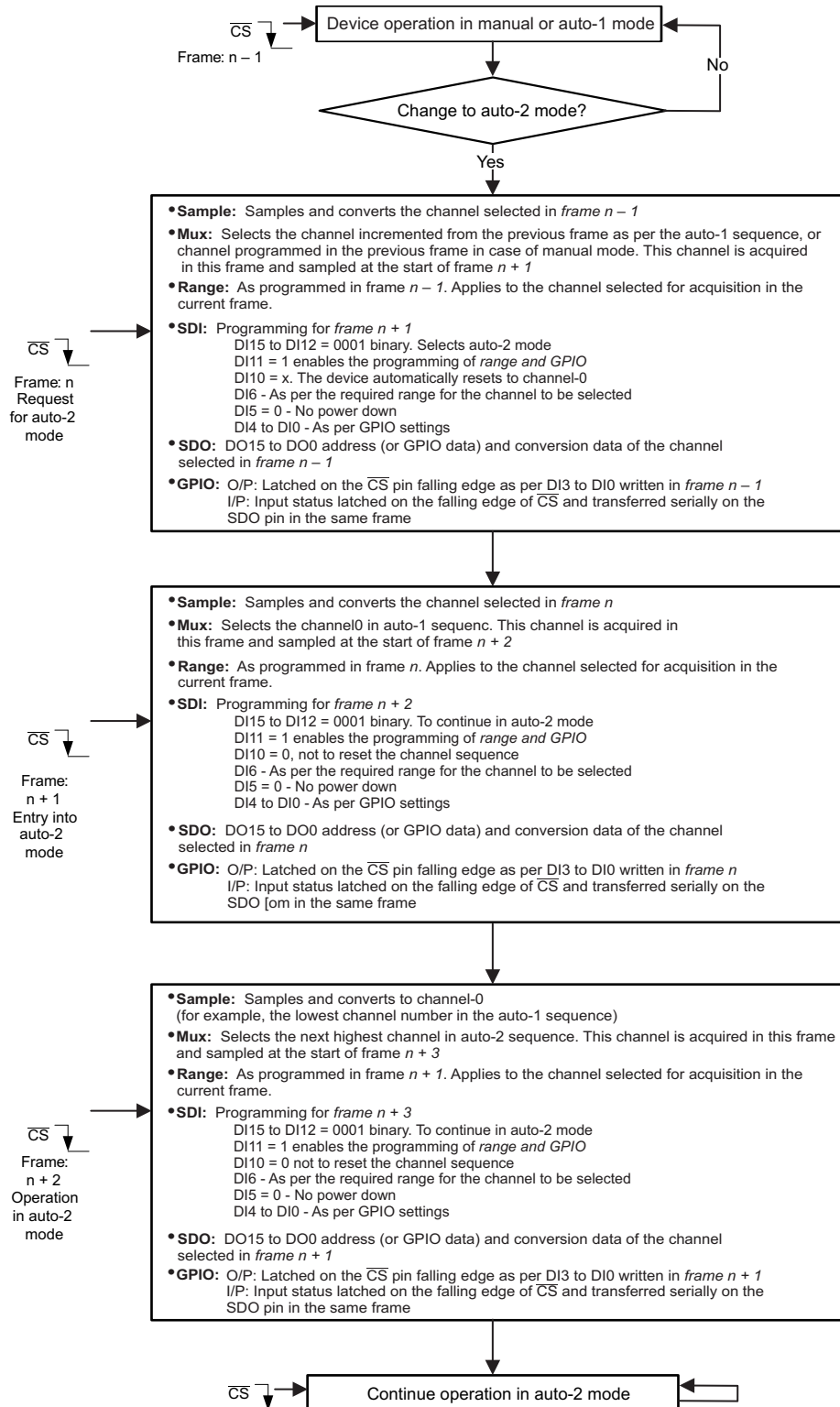
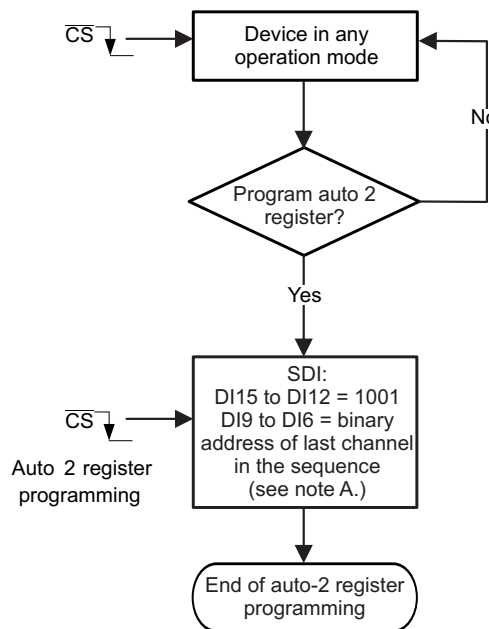

Figure 54. Entering and Running in Auto-2 Channel-Sequencing Mode

The auto-2 program register is programmed (once on power up or reset) to preselect the last channel (or sequence depth) in the auto-2 sequence. Unlike auto-1 program-register programming, auto-2 program-register programming requires only one CS frame for complete programming. Figure 55 and Table 6 provide complete details.



A. See Table 6.

B. The device continues operation in the selected mode during programming. The SDO pin is valid, however changing the range or writing the GPIO data into the device during programming is not possible.

Figure 55. Auto-2 Register Programming Flowchart

Table 6. Program Register Settings for Auto-2 Mode

BITS	RESET STATE	DESCRIPTION	
		LOGIC STATE	FUNCTION
DI15-12	NA	1001	The auto-2 program register is selected for programming
DI11-10	NA	Do not care	
DI09-06	NA	aaaa	This 4-bit data represents the address of the last channel in the scanning sequence. During device operation in auto-2 mode, the channel counter begins at CH-00 and increments every frame until the counter equals aaaa. The channel counter then rolls over to CH-00 in the next frame.
DI05-00	NA	Do not care	

8.4.6 Continued Operation In A Selected Mode

When a device is programmed to operate in one of the modes, the user can continue to operate in the same mode. Table 7 lists mode-control register settings to continue operating in a selected mode.

Table 7. Continued Operation in a Selected Mode

BITS	RESET STATE	DESCRIPTION	
		LOGIC STATE	FUNCTION
DI15-12	0001	0000	The device continues to operate in the selected mode. In auto-1 and auto-2 modes the channel counter increments normally, whereas in the manual mode the device continues with the last selected channel. The device ignores data on bits DI11-DI00 and continues operating as per the previous settings. This feature is provided so that the SDI pin can be held low when no changes are required in the mode-control register settings.
DI11-00	All 0		The device ignores these bits when bit DI15-12 is set to 0000 logic state

8.5 Digital Output Code

As discussed previously in the [Device Operation](#) section, the digital output of the ADS79xx-Q1 devices is SPI™ compatible. [Table 8](#), [Table 9](#), and [Table 10](#) list the output codes corresponding to various analog input voltages.

**Table 8. Ideal Input Voltages and Output Codes for 8-Bit Devices
(ADS7958, ADS7959, ADS7960, and ADS7961)**

DESCRIPTION	ANALOG VALUE		DIGITAL OUTPUT STRAIGHT BINARY	
			BINARY CODE	HEX CODE
Full-scale range	Range 1 → V_{ref}	Range 2 → $2 \times V_{ref}$	—	—
Least-significant bit (LSB)	$V_{ref} / 256$	$2 \times V_{ref} / 256$	—	—
Full scale	$V_{ref} - 1 \text{ LSB}$	$2 \times V_{ref} - 1 \text{ LSB}$	1111 1111	FF
Midscale	$V_{ref} / 2$	V_{ref}	1000 0000	80
Midscale – 1 LSB	$V_{ref} / 2 - 1 \text{ LSB}$	$V_{ref} - 1 \text{ LSB}$	0111 1111	7F
Zero	0 V	0 V	0000 0000	00

**Table 9. Ideal Input Voltages and Output Codes for 10-Bit Devices
(ADS7958, ADS7959, ADS7960, and ADS7961)**

DESCRIPTION	ANALOG VALUE		DIGITAL OUTPUT STRAIGHT BINARY	
			BINARY CODE	HEX CODE
Full-scale range	Range 1 → V_{ref}	Range 2 → $2 \times V_{ref}$	—	—
Least-significant bit (LSB)	$V_{ref} / 1024$	$2 \times V_{ref} / 1024$	—	—
Full scale	$V_{ref} - 1 \text{ LSB}$	$2 \times V_{ref} - 1 \text{ LSB}$	11 1111 1111	3FF
Midscale	$V_{ref} / 2$	V_{ref}	10 0000 0000	200
Midscale – 1 LSB	$V_{ref} / 2 - 1 \text{ LSB}$	$V_{ref} - 1 \text{ LSB}$	01 1111 1111	1FF
Zero	0 V	0 V	00 0000 0000	000

**Table 10. Ideal Input Voltages and Output Codes for 12-Bit Devices
(ADS7950, ADS7951, ADS7952, and ADS7953)**

DESCRIPTION	ANALOG VALUE		DIGITAL OUTPUT STRAIGHT BINARY	
			BINARY CODE	HEX CODE
Full-scale range	Range 1 → V_{ref}	Range 2 → $2 \times V_{ref}$	—	—
Least-significant bit (LSB)	$V_{ref} / 4096$	$2 \times V_{ref} / 4096$	—	—
Full scale	$V_{ref} - 1 \text{ LSB}$	$2 \times V_{ref} - 1 \text{ LSB}$	1111 1111 1111	FFF
Midscale	$V_{ref} / 2$	V_{ref}	1000 0000 0000	800
Midscale – 1 LSB	$V_{ref} / 2 - 1 \text{ LSB}$	$V_{ref} - 1 \text{ LSB}$	0111 1111 1111	7FF
Zero	0 V	0 V	0000 0000 0000	000

8.6 Programming: GPIO

8.6.1 GPIO Registers

The device has four general-purpose input and output (GPIO) pins. Each of the four pins can be independently programmed as general purpose output (GPO) or general purpose input (GPI). Using the GPIOs pins for some preassigned functions (see [Table 11](#)) is possible. The GPO data can be written into the device through the SDI line. The device refreshes the GPO data on every \overline{CS} falling edge as per the SDI data written in the previous frame. Similarly, the device latches the GPI status on the \overline{CS} falling edge and outputs it on the SDO pin (if the GPI pin is read-enabled by writing bit DI04 equal to 1 during the previous frame) in the same frame starting on the CS falling edge.

[Figure 56](#) shows the details regarding programming the GPIO registers. [Table 11](#) lists the details regarding GPIO-register programming settings.

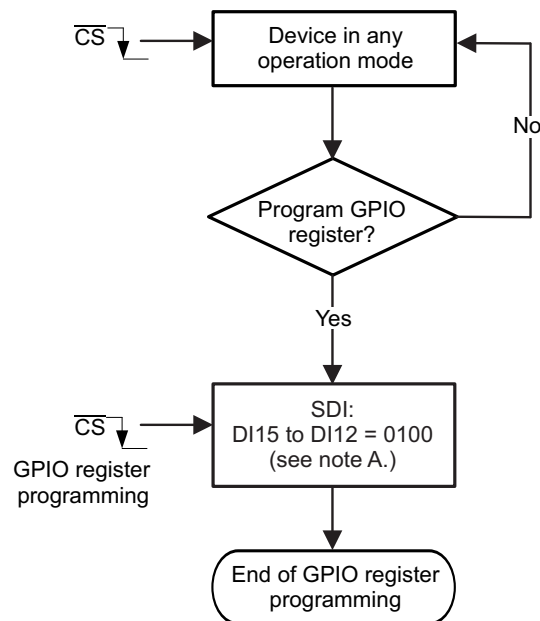

A. See [Table 12](#) for DI11 to DI00 data.

B. The device continues its operation in selected mode during programming. SDO is valid, however changing the range or writing GPIO data into the device during programming is not possible.

Figure 56. GPIO Program-Register Programming Flowchart

Programming: GPIO (continued)
Table 11. GPIO Program-Register Settings

BITS	RESET STATE	DESCRIPTION	
		LOGIC STATE	FUNCTION
DI15-12	NA	0100	The device selects GPIO program registers for programming.
DI11-10	00	00	Do not program these bits to any logic state other than 00.
DI09	0	1	The device resets all registers in the next \overline{CS} frame to the reset state shown in the corresponding tables (the device also resets itself).
		0	Device normal operation.
DI08	0	1	The device configures the GPIO3 pin as the device power-down input.
		0	The GPIO3 pin remains a general-purpose input or output.
DI07	0	1	The device configures the GPIO2 pin as a device-range input.
		0	The GPIO2 pin remains a general-purpose input or output.
DI06-04	000	000	The GPIO1 and GPIO0 pins remain a general-purpose input or output.
		xx1	The device configures the GPIO0 pin as a high-alarm or low-alarm output. This output is active high. GPIO1 remains general-purpose input or output.
		010	The device configures GPIO0 as a high-alarm output. This output is active high. The GPIO1 pin remains a general-purpose input or output.
		100	The device configures GPIO1 as a low-alarm output. This output is active high. The GPIO0 pin remains a general-purpose input or output.
		110	The device configures GPIO1 as a low-alarm output and the GPIO0 pin as a high-alarm output. These outputs are active high.
Note: The following settings are valid for the GPIO pins that are not assigned a specific function through bits DI08 to DI04			
DI03	0	1	The GPIO3 pin is configured as general-purpose output.
		0	The GPIO3 pin is configured as general-purpose input.
DI02	0	1	The GPIO2 pin is configured as general-purpose output.
		0	The GPIO2 pin is configured as general-purpose input.
DI01	0	1	The GPIO1 pin is configured as general-purpose output.
		0	The GPIO1 pin is configured as general-purpose input.
DI00	0	1	The GPIO0 pin is configured as general-purpose output.
		0	The GPIO0 pin is configured as general-purpose input.

8.6.2 Alarm Thresholds for GPIO Pins

Each channel has two alarm program registers, one for setting the high alarm threshold and the other for setting the low alarm threshold. For ease of programming, two alarm programming registers per channel, corresponding to four consecutive channels, are assembled into one group (a total of eight registers). There are four of these groups for 16-channel devices, and one, two or three of these groups for the 12-, 8-, or 4-channel devices, respectively. [Table 12](#) lists the grouping of the various channels for each device in the ADS79xx-Q1 family. [Figure 57](#) illustrates the details regarding programming the alarm thresholds. [Table 13](#) lists the details regarding the alarm-program register settings.

Table 12. Grouping of Alarm Program Registers

GROUP NUMBER	REGISTERS	APPLICABLE FOR DEVICE
0	High and low alarm for channel 0, 1, 2, and 3	ADS750, ADS7952, ADS7951, and ADS7953; ADS7954, ADS7956, and ADS7957; ADS7958, ADS7959, ADS7960, and ADS7961
1	High and low alarm for channel 4, 5, 6, and 7	ADS7951, ADS7952, and ADS7953; ADS7956, and ADS7957; ADS7959, ADS7960, and ADS7961
2	High and low alarm for channel 8, 9, 10, and 11	ADS7953 and ADS7952, ADS7957 and ADS7956, ADS7961 and ADS7960
3	High and low alarm for channel 12, 13, 14, and 15	ADS7953, ADS7957, and ADS7961

Each alarm group requires nine \overline{CS} frames for programming the respective alarm thresholds. In the first frame the device enters the programming sequence and in each subsequent frame the device programs one of the registers from the group. The device offers a feature to program less than eight registers in one programming sequence. The device exits the alarm threshold programming sequence in the next frame after encountering the first exit alarm program bit high.

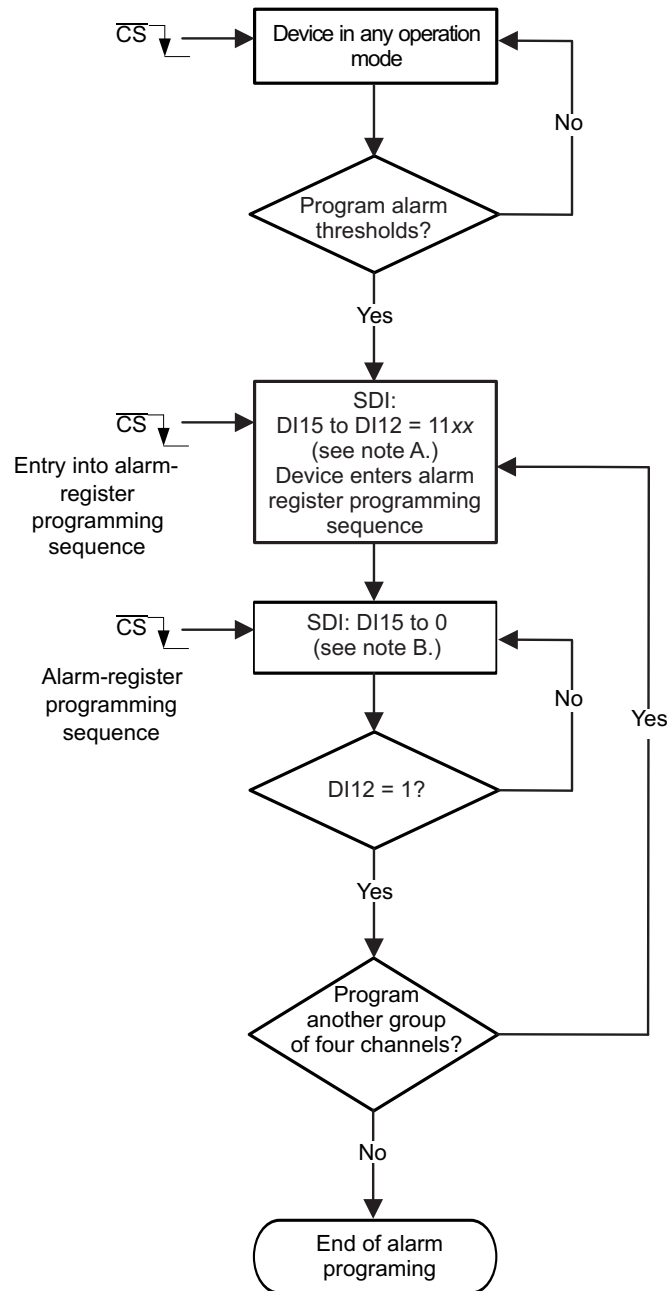

A. xx indicates a group of four channels (see Table 12).

B. Per Table 12.

C. The device continues operation in the selected mode during programming. The SDO pin is valid, however changing the range or writing the GPIO data into the device during programming is not possible.

Figure 57. Alarm Program Register Programming Flowchart

Table 13. Alarm Program Register Settings

BITS	RESET STATE	DESCRIPTION	
		LOGIC STATE	FUNCTION
FRAME 1			
DI15-12	NA	1100	The device enters alarm programming sequence for group 0
		1101	The device enters alarm programming sequence for group 1
		1110	The device enters alarm programming sequence for group 2
		1111	The device enters alarm programming sequence for group 3
Note: Bits DI15-12 = 11 <i>bb</i> is the alarm programming request for group <i>bb</i> . Here, <i>bb</i> represents the alarm programming group number in binary format.			
DI11-14	NA	Do not care	
FRAME 2 AND ONWARDS			
DI15-14	NA	<i>cc</i>	Where <i>cc</i> represents the lower two bits of the channel number in binary format. The device programs the alarm for the channel represented by the binary number <i>bbcc</i> . Note that <i>bb</i> is programmed in the first frame.
DI13	NA	1	High-alarm register selection
		0	Low-alarm register selection
DI12	NA	0	Continue alarm programming sequence in next frame
		1	Exit alarm programming in the next frame. Note: If the alarm programming sequence is not terminated using this feature then the device remains in the alarm programming sequence state and all SDI data is treated as alarm thresholds.
DI11-10	NA	<i>xx</i>	Do not care
DI09-00	All ones for high alarm register and all zeros for low alarm register	This 10-bit data represents the alarm threshold. The 10-bit alarm threshold is compared with the upper 10-bit word of the 12-bit conversion result. The device sets off an alarm when the conversion result is higher (high alarm) or lower (low alarm) than this number. For 10-bit devices, all 10 bits of the conversion result are compared with the set threshold. For 8-bit devices, all 8 bits of the conversion result are compared with DI09 to DI02 and DI00 and DI01 are <i>do not care</i> .	

9 Application and Implementation

9.1 Application Information

In general applications, when the internal multiplexer is updated, the previously converted channel charge is stored in the 15-pF internal input capacitance that disturbs the voltage at the newly selected channel. This disturbance is expected to settle to 1 LSB during sampling (acquisition) time to avoid degrading converter performance. The initial absolute disturbance error at the channel input must be less than 0.5 V to prevent source current saturation or slewing that causes significantly long settling times. Fortunately, significantly reducing disturbance error is easy to accomplish by simply placing a large enough capacitor at the input of each channel. Specifically, with a 150-pF capacitor, instantaneous charge distribution keeps disturbance error below 0.46 V because the internal input capacitance can only hold up to 75 pC (or $5\text{ V} \times 15\text{ pF}$). The remaining error must be corrected by the voltage source at each input, with impedance low enough to settle within 1 LSB. The following application examples explain the considerations for the input source impedance (R_{SOURCE}).

9.2 Typical Applications

9.2.1 Unbuffered Multiplexer Output (MXO)

This application is the most typical application, but requires the lowest R_{SOURCE} for good performance. In this configuration, the 2xREF range allows larger source impedance than the 1xREF range because the 1xREF range LSB size is smaller, thus making it more sensitive to settling error.

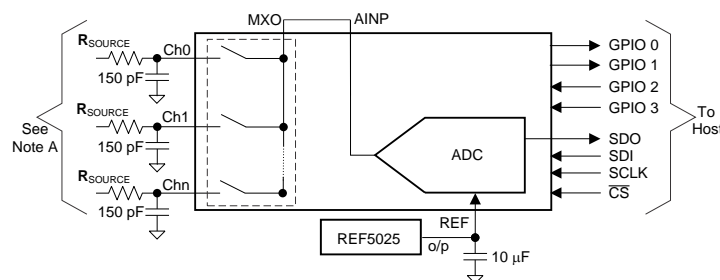

A. A restriction on the source impedance exists. $R_{\text{SOURCE}} \leq 100\ \Omega$ for the 1xREF 12-bit settling at 1 MSPS or $R_{\text{SOURCE}} \leq 250\ \Omega$ for the 1xREF 12-bit settling at 1 MSPS.

Figure 58. Application Diagram for an Unbuffered MXO

9.2.1.1 Design Requirements

The design is optimized to show the input source impedance (R_{SOURCE}) between the 100 Ω to 10,000 Ω required to meet the 1-LSB settling at 12-bit, 10-bit, and 8-bit resolutions at different throughput in 1xREF (2.5-V) and 2xREF (5-V) input ranges.

9.2.1.2 Detailed Design Procedure

Although the required input source impedance can be estimated assuming a 0.5-V initial error and exponential recovery during sampling (acquisition) time, this estimation over-simplifies the complex interaction between the converter and source, thus yielding inaccurate estimates. Thus, this design uses an iterative approach with the converter itself to provide reliable impedance values.

To determine the actual maximum source impedance for a particular resolution and sampling rate, two subsequent channels are set at least 95% of the full-scale range apart. With a 1xREF range and $2.5\text{ V}_{\text{ref}}$, the channel difference is at least 2.375 V. With 2xREF and $2.5\text{ V}_{\text{ref}}$, the difference is at least 4.75 V. With a source impedance between 100 Ω to 10,000 Ω , the conversion runs at a constant rate and a channel update is issued that captures the first couple samples after the update. This process is repeated at least 100 times to remove any noise and to show a clear settling error. The first sample after the channel update is then compared against the second one. If the first and second samples are more than 1 LSB apart, throughput rate is reduced until the settling error becomes 1 LSB, which then sets the maximum throughput for the selected impedance. The whole process is repeated for nine different impedances between 100 Ω to 10,000 Ω .

Typical Applications (continued)

9.2.1.3 Application Curves

These curves show the R_{SOURCE} for an unbuffered MXO.

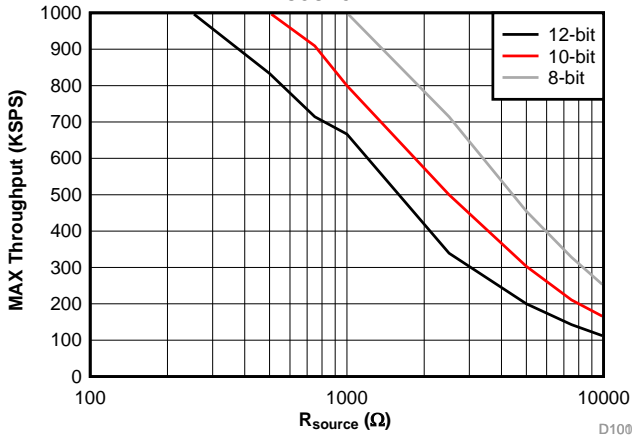

Figure 59. 2xREF Input Range Settling without an MXO Buffer

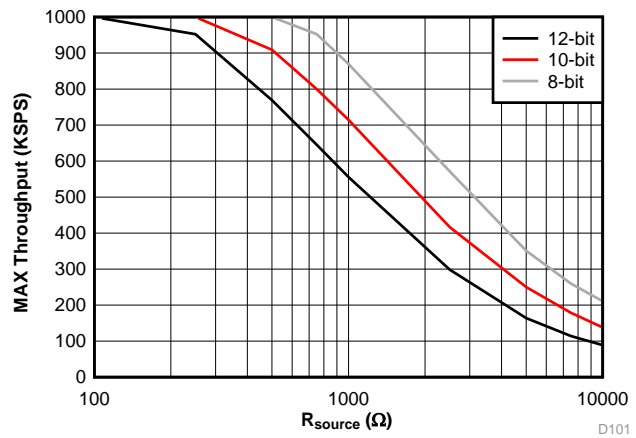
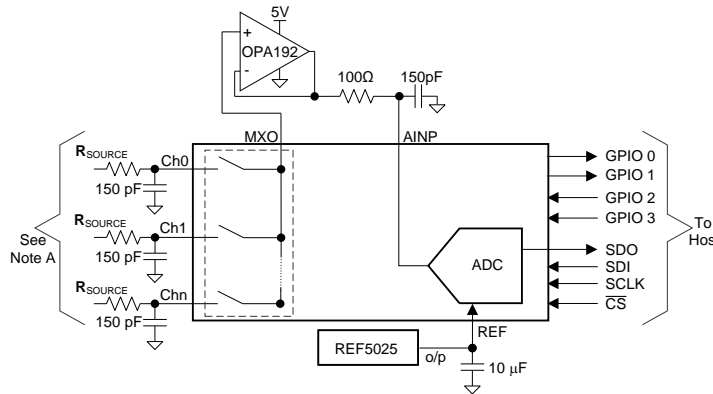

Figure 60. 1xREF Input Range Settling without an MXO Buffer

9.2.2 OPA192 Buffered Multiplexer Output (MXO)

The use of a buffer relaxes the R_{SOURCE} requirements to an extent. Charge from the sample-and-hold capacitor no longer dominates as a residual charge from a previous channel. Although having good performance is possible with a larger impedance using the OPA192, the output capacitance of the MXO also holds the previous channel charge and cannot be isolated, which limits how large the input impedance can finally be for good performance. In this configuration, the 1xREF range allows slightly higher impedance because the OPA192 (20 V/ μ s) slews approximately 2.5 V in contrast to the 2xREF range that requires the OPA192 to slew approximately 5 V.



A. Restriction on the source impedance exists. $R_{(SOURCE)} \leq 500 \Omega$ for a 12-bit settling at 1 MSPS with both 1xREF and 2xREF ranges.

Figure 61. Application Diagram for an OPA192 Buffered MXO

9.2.2.1 Design Requirements

The design is optimized to show the input source impedance (R_{SOURCE}) between the 100 Ω to 10,000 Ω required to meet a 1-LSB settling at 12-bit, 10-bit, and 8-bit resolutions at different throughput in 1xREF (2.5 V) and 2xREF (5 V) input ranges.

Typical Applications (continued)

9.2.2.2 Detailed Design Procedure

The design procedure is similar to the unbuffered-MXO application, but includes an operation amplifier in unity gain as a buffer. The most important parameter for multiplexer buffering is slew rate. The amplifier must finish slewing before the start of sampling (acquisition) to keep the buffer operating in small-signal mode during sampling (acquisition) time. Also, between the buffer output and converter input (INP), there must be a capacitor large enough to keep the buffer in small-signal operation during sampling (acquisition) time. Because 150 pF is large enough to protect the buffer from hold charge from internal capacitors, this value selected along with the lowest impedance that allows the op amp to remain stable.

The converter allows the MXO to settle approximately 600 ns before sampling. During this time, the buffer slews and then enters small-signal operation. For a 5-V step change, slew rate stays constant during the first 4 V. The last 1 V includes a transition from slewing and non-slewing. Thus, the buffer cannot be assumed to keep a constant slew during the 600 ns available for MXO settling. Assuming that the last 1-V slew is reduced to half is recommended. For this reason, slew is 10 V/ μ s or $(5 V_{ref} + 1 V) / 0.6 \mu$ s to account for the 1-V slow slew. The OPA192 has a 20-V/ μ s slew, and is capable of driving 150 pF with more than a 50° phase margin with a 50- Ω or 100- Ω R_{iso} , making the OPA192 an ideal selection for the ADS79xx-Q1 family of converters.

9.2.2.3 Application Curves

These curves show the R_{SOURCE} for an OPA192 buffered MXO.

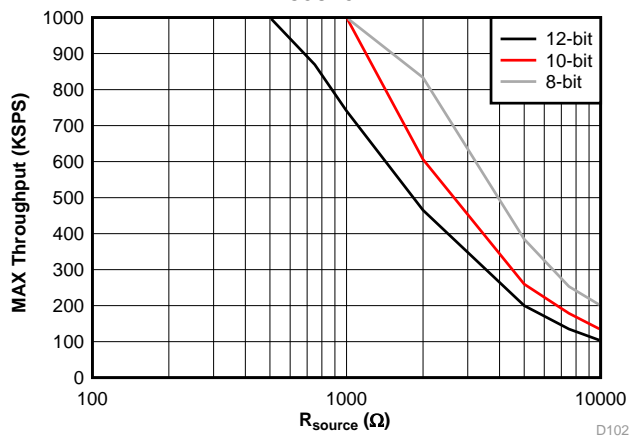

Figure 62. 2xREF Input Range Settling with an OPA192 MXO Buffer

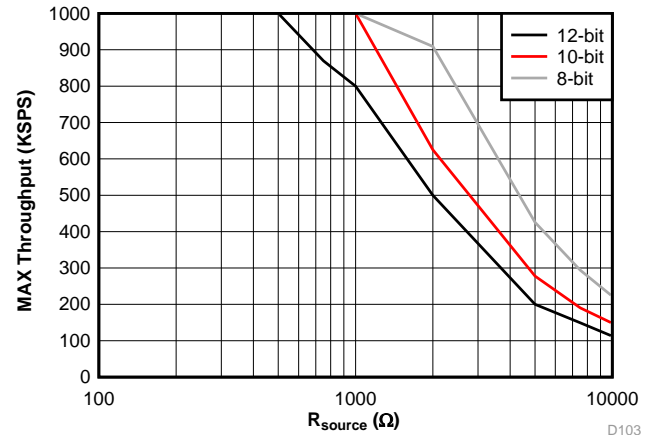

Figure 63. 1xREF Input Range Settling with an OPA192 MXO Buffer

9.3 Do's and Don'ts

- Use capacitors to decouple the dynamic current transients at each pins, including reference, supply, and input signal.
- Do not place capacitors on the MXO pin. This placement causes issues with the signal settling when the multiplexer changes channels.
- Depending on the PCB layout, there can be parasitic inductance on the SCLK trace that causes ringing. To minimize ringing, do not place a capacitor at the SCLK pin. Instead, place a small resistor in series with the SCLK pin to slow down the clock edges.

10 Power-Supply Recommendations

The devices are designed to operate from an analog supply voltage ($V_{(+VA)}$) range between 2.7 V and 5.25 V and a digital supply voltage ($V_{(+VBD)}$) range between 1.7 V and 5.25 V. Both supplies must be well regulated. The analog supply is always greater than or equal to the digital supply. A 1- μ F ceramic decoupling capacitor is required at each supply pin and must be placed as close as possible to the device.

11 Layout

11.1 Layout Guidelines

- A copper fill area underneath the device ties the AGND, BDGND, AINM, and REFM pins together. This copper fill area must also be connected to the analog ground plane of the PCB using at least four vias.
- The power sources must be clean and properly decoupled by placing a capacitor close to each of the three supply pins, as shown in Figure 64. To minimize ground inductance, ensure that each capacitor ground pin is connected to a grounding via by a very short and thick trace.
- The REFP pin requires a 10- μF ceramic capacitor to meet performance specifications. Place the capacitor directly next to the device. This capacitor ground pin must be routed to the REFM pin by a very short trace, as shown in Figure 64.
- Do not place any vias between a capacitor pin and a device pin.

NOTE

The full-power bandwidth of the converter makes the ADC sensitive to high frequencies in digital lines. Organize components in the PCB by keeping digital lines apart from the analog signal paths. This design configuration is critical to minimize crosstalk. For example, in Figure 64, input drivers are expected to be on the left of the converter and the microcontroller on the right.

11.2 Layout Example

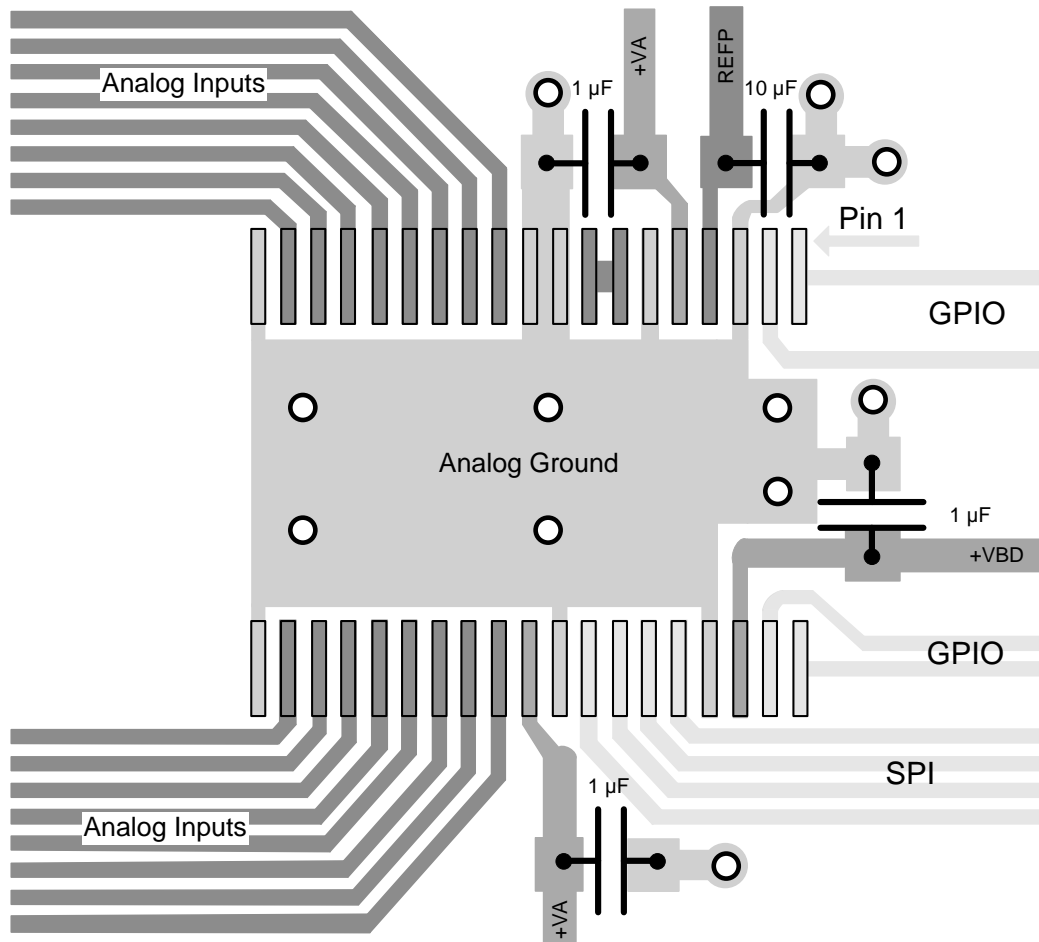

Figure 64. Layout Example

12 器件和文档支持

12.1 文档支持

12.1.1 相关文档

相关文档如下：

- REF5025 数据表, [SBOS410](#)
- OPA192 数据表, [SBOS620](#)

12.2 相关链接

以下表格列出了快速访问链接。范围包括技术文档、支持与社区资源、工具和软件，并且可以快速访问样片或购买链接。

表 14. 相关链接

部件	产品文件夹	样片与购买	技术文档	工具与软件	支持与社区
ADS7950-Q1	请单击此处	请单击此处	请单击此处	请单击此处	请单击此处
ADS7951-Q1	请单击此处	请单击此处	请单击此处	请单击此处	请单击此处
ADS7952-Q1	请单击此处	请单击此处	请单击此处	请单击此处	请单击此处
ADS7953-Q1	请单击此处	请单击此处	请单击此处	请单击此处	请单击此处
ADS7954-Q1	请单击此处	请单击此处	请单击此处	请单击此处	请单击此处
ADS7956-Q1	请单击此处	请单击此处	请单击此处	请单击此处	请单击此处
ADS7957-Q1	请单击此处	请单击此处	请单击此处	请单击此处	请单击此处
ADS7958-Q1	请单击此处	请单击此处	请单击此处	请单击此处	请单击此处
ADS7959-Q1	请单击此处	请单击此处	请单击此处	请单击此处	请单击此处
ADS7960-Q1	请单击此处	请单击此处	请单击此处	请单击此处	请单击此处
ADS7961-Q1	请单击此处	请单击此处	请单击此处	请单击此处	请单击此处

12.3 商标

SPI is a trademark of Motorola Inc.

All other trademarks are the property of their respective owners.

12.4 静电放电警告



ESD 可能会损坏该集成电路。德州仪器 (TI) 建议通过适当的预防措施处理所有集成电路。如果不遵守正确的处理措施和安装程序，可能会损坏集成电路。

ESD 的损坏小至导致微小的性能降级，大至整个器件故障。精密的集成电路可能更容易受到损坏，这是因为非常细微的参数更改都可能会导致器件与其发布的规格不相符。

12.5 术语表

[SLYZ022](#) — TI 术语表。

这份术语表列出并解释术语、首字母缩略词和定义。

13 机械封装和可订购信息

以下页中包括机械封装和可订购信息。 这些信息是针对指定器件可提供的最新数据。 这些数据会在无通知且不对本文档进行修订的情况下发生改变。 欲获得该数据表的浏览器版本，请查阅左侧的导航栏。

重要声明

德州仪器(TI)及其下属子公司有权根据 JESD46 最新标准,对所提供的产品和服务进行更正、修改、增强、改进或其它更改,并有权根据 JESD48 最新标准中止提供任何产品和服务。客户在下订单前应获取最新的相关信息,并验证这些信息是否完整且是最新的。所有产品的销售都遵循在订单确认时所提供的TI 销售条款与条件。

TI 保证其所销售的组件的性能符合产品销售时 TI 半导体产品销售条件与条款的适用规范。仅在 TI 保证的范围内,且 TI 认为有必要时才会使用测试或其它质量控制技术。除非适用法律做出了硬性规定,否则没有必要对每种组件的所有参数进行测试。

TI 对应用帮助或客户产品设计不承担任何义务。客户应对其使用 TI 组件的产品和应用自行负责。为尽量减小与客户产品和应用相关的风险,客户应提供充分的设计与操作安全措施。

TI 不对任何 TI 专利权、版权、屏蔽作品权或其它与使用了 TI 组件或服务的组合设备、机器或流程相关的 TI 知识产权中授予的直接或隐含权限作出任何保证或解释。TI 所发布的与第三方产品或服务有关的信息,不能构成从 TI 获得使用这些产品或服务的许可、授权、或认可。使用此类信息可能需要获得第三方的专利权或其它知识产权方面的许可,或是 TI 的专利权或其它知识产权方面的许可。

对于 TI 的产品手册或数据表中 TI 信息的重要部分,仅在没有对内容进行任何篡改且带有相关授权、条件、限制和声明的情况下才允许进行复制。TI 对此类篡改过的文件不承担任何责任或义务。复制第三方的信息可能需要服从额外的限制条件。

在转售 TI 组件或服务时,如果对该组件或服务参数的陈述与 TI 标明的参数相比存在差异或虚假成分,则会失去相关 TI 组件或服务的所有明示或暗示授权,且这是不正当的、欺诈性商业行为。TI 对任何此类虚假陈述均不承担任何责任或义务。

客户认可并同意,尽管任何应用相关信息或支持仍可能由 TI 提供,但他们将独立负责满足与其产品及其在应用中使用的 TI 产品相关的所有法律、法规和安全相关要求。客户声明并同意,他们具备制定与实施安全措施所需的全部专业技术和知识,可预见故障的危险后果、监测故障及其后果、降低有可能造成人身伤害的故障的发生机率并采取适当的补救措施。客户将全额赔偿因在此类安全关键应用中使用任何 TI 组件而对 TI 及其代理造成的任何损失。

在某些场合中,为了推进安全相关应用有可能对 TI 组件进行特别的促销。TI 的目标是利用此类组件帮助客户设计和创立其特有的可满足适用的功能安全性标准和要求的终端产品解决方案。尽管如此,此类组件仍然服从这些条款。

TI 组件未获得用于 FDA Class III (或类似的生命攸关医疗设备)的授权许可,除非各方授权官员已经达成了专门管控此类使用的特别协议。

只有那些 TI 特别注明属于军用等级或“增强型塑料”的 TI 组件才是设计或专门用于军事/航空应用或环境的。购买者认可并同意,对并非指定面向军事或航空航天用途的 TI 组件进行军事或航空航天方面的应用,其风险由客户单独承担,并且由客户独立负责满足与此类使用相关的所有法律和法规要求。

TI 已明确指定符合 ISO/TS16949 要求的产品,这些产品主要用于汽车。在任何情况下,因使用非指定产品而无法达到 ISO/TS16949 要求, TI 不承担任何责任。

	产品		应用
数字音频	www.ti.com.cn/audio	通信与电信	www.ti.com.cn/telecom
放大器和线性器件	www.ti.com.cn/amplifiers	计算机及周边	www.ti.com.cn/computer
数据转换器	www.ti.com.cn/dataconverters	消费电子	www.ti.com.cn/consumer-apps
DLP® 产品	www.dlp.com	能源	www.ti.com.cn/energy
DSP - 数字信号处理器	www.ti.com.cn/dsp	工业应用	www.ti.com.cn/industrial
时钟和计时器	www.ti.com.cn/clockandtimers	医疗电子	www.ti.com.cn/medical
接口	www.ti.com.cn/interface	安防应用	www.ti.com.cn/security
逻辑	www.ti.com.cn/logic	汽车电子	www.ti.com.cn/automotive
电源管理	www.ti.com.cn/power	视频和影像	www.ti.com.cn/video
微控制器 (MCU)	www.ti.com.cn/microcontrollers		
RFID 系统	www.ti.com.cn/rfidsys		
OMAP应用处理器	www.ti.com/omap		
无线连通性	www.ti.com.cn/wirelessconnectivity	德州仪器在线技术支持社区	www.deyisupport.com

邮寄地址: 上海市浦东新区世纪大道1568号, 中建大厦32楼邮政编码: 200122
Copyright © 2014, 德州仪器半导体技术(上海)有限公司

PACKAGING INFORMATION

Orderable Device	Status (1)	Package Type	Package Drawing	Pins	Package Qty	Eco Plan (2)	Lead/Ball Finish (6)	MSL Peak Temp (3)	Op Temp (°C)	Device Marking (4/5)	Samples
ADS7950QDBTRQ1	ACTIVE	TSSOP	DBT	30	2000	Green (RoHS & no Sb/Br)	CU NIPDAU	Level-3-260C-168 HR	-40 to 125	ADS7950Q	Samples
ADS7951QDBTRQ1	ACTIVE	TSSOP	DBT	30	2000	Green (RoHS & no Sb/Br)	CU NIPDAU	Level-3-260C-168 HR	-40 to 125	ADS7951Q	Samples
ADS7952QDBTRQ1	ACTIVE	TSSOP	DBT	38	2000	Green (RoHS & no Sb/Br)	CU NIPDAU	Level-3-260C-168 HR	-40 to 125	ADS7952Q	Samples
ADS7953QDBTRQ1	ACTIVE	TSSOP	DBT	38	2000	Green (RoHS & no Sb/Br)	CU NIPDAU	Level-3-260C-168 HR	-40 to 125	ADS7953Q	Samples
ADS7954QDBTRQ1	ACTIVE	TSSOP	DBT	30	2000	Green (RoHS & no Sb/Br)	CU NIPDAU	Level-3-260C-168 HR	-40 to 125	ADS7954Q	Samples
ADS7956QDBTRQ1	ACTIVE	TSSOP	DBT	38	2000	Green (RoHS & no Sb/Br)	CU NIPDAU	Level-3-260C-168 HR	-40 to 125	ADS7956Q	Samples
ADS7957QDBTRQ1	ACTIVE	TSSOP	DBT	38	2000	Green (RoHS & no Sb/Br)	CU NIPDAU	Level-3-260C-168 HR	-40 to 125	ADS7957Q	Samples
ADS7958QDBTRQ1	ACTIVE	TSSOP	DBT	30	2000	Green (RoHS & no Sb/Br)	CU NIPDAU	Level-3-260C-168 HR	-40 to 125	ADS7958Q	Samples
ADS7959QDBTRQ1	ACTIVE	TSSOP	DBT	30	2000	Green (RoHS & no Sb/Br)	CU NIPDAU	Level-3-260C-168 HR	-40 to 125	ADS7959Q	Samples
ADS7960QDBTRQ1	ACTIVE	TSSOP	DBT	38	2000	Green (RoHS & no Sb/Br)	CU NIPDAU	Level-3-260C-168 HR	-40 to 125	ADS7960Q	Samples
ADS7961QDBTRQ1	ACTIVE	TSSOP	DBT	38	2000	Green (RoHS & no Sb/Br)	CU NIPDAU	Level-3-260C-168 HR	-40 to 125	ADS7961Q	Samples

(1) The marketing status values are defined as follows:

ACTIVE: Product device recommended for new designs.

LIFEBUY: TI has announced that the device will be discontinued, and a lifetime-buy period is in effect.

NRND: Not recommended for new designs. Device is in production to support existing customers, but TI does not recommend using this part in a new design.

PREVIEW: Device has been announced but is not in production. Samples may or may not be available.

OBSELETE: TI has discontinued the production of the device.

(2) Eco Plan - The planned eco-friendly classification: Pb-Free (RoHS), Pb-Free (RoHS Exempt), or Green (RoHS & no Sb/Br) - please check <http://www.ti.com/productcontent> for the latest availability information and additional product content details.

TBD: The Pb-Free/Green conversion plan has not been defined.

Pb-Free (RoHS): TI's terms "Lead-Free" or "Pb-Free" mean semiconductor products that are compatible with the current RoHS requirements for all 6 substances, including the requirement that lead not exceed 0.1% by weight in homogeneous materials. Where designed to be soldered at high temperatures, TI Pb-Free products are suitable for use in specified lead-free processes.

Pb-Free (RoHS Exempt): This component has a RoHS exemption for either 1) lead-based flip-chip solder bumps used between the die and package, or 2) lead-based die adhesive used between the die and leadframe. The component is otherwise considered Pb-Free (RoHS compatible) as defined above.

Green (RoHS & no Sb/Br): TI defines "Green" to mean Pb-Free (RoHS compatible), and free of Bromine (Br) and Antimony (Sb) based flame retardants (Br or Sb do not exceed 0.1% by weight in homogeneous material)

⁽³⁾ MSL, Peak Temp. - The Moisture Sensitivity Level rating according to the JEDEC industry standard classifications, and peak solder temperature.

⁽⁴⁾ There may be additional marking, which relates to the logo, the lot trace code information, or the environmental category on the device.

⁽⁵⁾ Multiple Device Markings will be inside parentheses. Only one Device Marking contained in parentheses and separated by a "~" will appear on a device. If a line is indented then it is a continuation of the previous line and the two combined represent the entire Device Marking for that device.

⁽⁶⁾ Lead/Ball Finish - Orderable Devices may have multiple material finish options. Finish options are separated by a vertical ruled line. Lead/Ball Finish values may wrap to two lines if the finish value exceeds the maximum column width.

Important Information and Disclaimer: The information provided on this page represents TI's knowledge and belief as of the date that it is provided. TI bases its knowledge and belief on information provided by third parties, and makes no representation or warranty as to the accuracy of such information. Efforts are underway to better integrate information from third parties. TI has taken and continues to take reasonable steps to provide representative and accurate information but may not have conducted destructive testing or chemical analysis on incoming materials and chemicals. TI and TI suppliers consider certain information to be proprietary, and thus CAS numbers and other limited information may not be available for release.

In no event shall TI's liability arising out of such information exceed the total purchase price of the TI part(s) at issue in this document sold by TI to Customer on an annual basis.

OTHER QUALIFIED VERSIONS OF ADS7950-Q1, ADS7951-Q1, ADS7952-Q1, ADS7953-Q1, ADS7954-Q1, ADS7956-Q1, ADS7957-Q1, ADS7958-Q1, ADS7959-Q1, ADS7960-Q1, ADS7961-Q1 :

● Catalog: [ADS7950](#), [ADS7951](#), [ADS7952](#), [ADS7953](#), [ADS7954](#), [ADS7956](#), [ADS7957](#), [ADS7958](#), [ADS7959](#), [ADS7960](#), [ADS7961](#)

NOTE: Qualified Version Definitions:

● Catalog - TI's standard catalog product

TAPE AND REEL INFORMATION

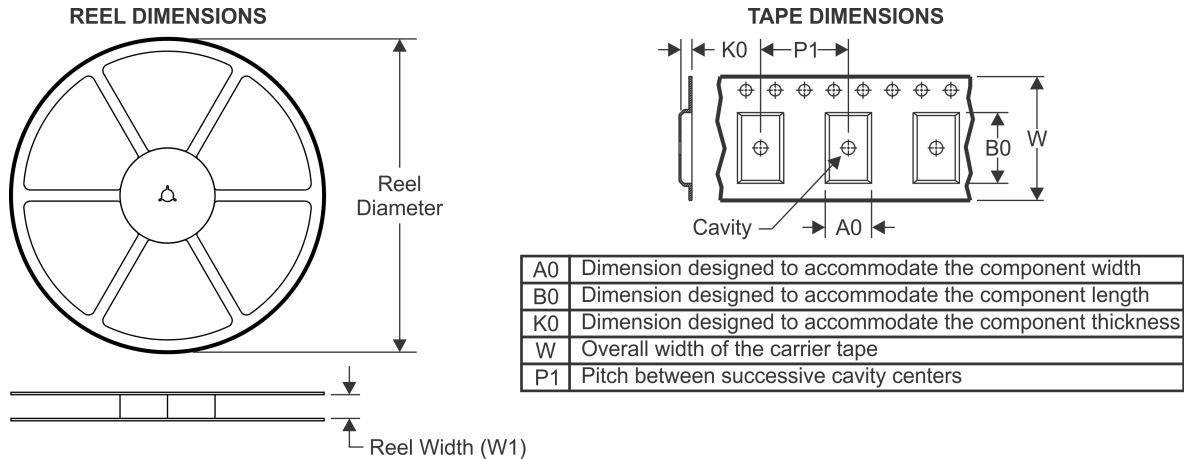

QUADRANT ASSIGNMENTS FOR PIN 1 ORIENTATION IN TAPE



*All dimensions are nominal

Device	Package Type	Package Drawing	Pins	SPQ	Reel Diameter (mm)	Reel Width W1 (mm)	A0 (mm)	B0 (mm)	K0 (mm)	P1 (mm)	W (mm)	Pin1 Quadrant
ADS7950QDBTRQ1	TSSOP	DBT	30	2000	330.0	16.4	6.95	8.3	1.6	8.0	16.0	Q1
ADS7951QDBTRQ1	TSSOP	DBT	30	2000	330.0	16.4	6.95	8.3	1.6	8.0	16.0	Q1
ADS7952QDBTRQ1	TSSOP	DBT	38	2000	330.0	16.4	6.9	10.2	1.8	12.0	16.0	Q1
ADS7953QDBTRQ1	TSSOP	DBT	38	2000	330.0	16.4	6.9	10.2	1.8	12.0	16.0	Q1
ADS7954QDBTRQ1	TSSOP	DBT	30	2000	330.0	16.4	6.95	8.3	1.6	8.0	16.0	Q1
ADS7956QDBTRQ1	TSSOP	DBT	38	2000	330.0	16.4	6.9	10.2	1.8	12.0	16.0	Q1
ADS7957QDBTRQ1	TSSOP	DBT	38	2000	330.0	16.4	6.9	10.2	1.8	12.0	16.0	Q1
ADS7958QDBTRQ1	TSSOP	DBT	30	2000	330.0	16.4	6.95	8.3	1.6	8.0	16.0	Q1
ADS7959QDBTRQ1	TSSOP	DBT	30	2000	330.0	16.4	6.95	8.3	1.6	8.0	16.0	Q1
ADS7960QDBTRQ1	TSSOP	DBT	38	2000	330.0	16.4	6.9	10.2	1.8	12.0	16.0	Q1
ADS7961QDBTRQ1	TSSOP	DBT	38	2000	330.0	16.4	6.9	10.2	1.8	12.0	16.0	Q1

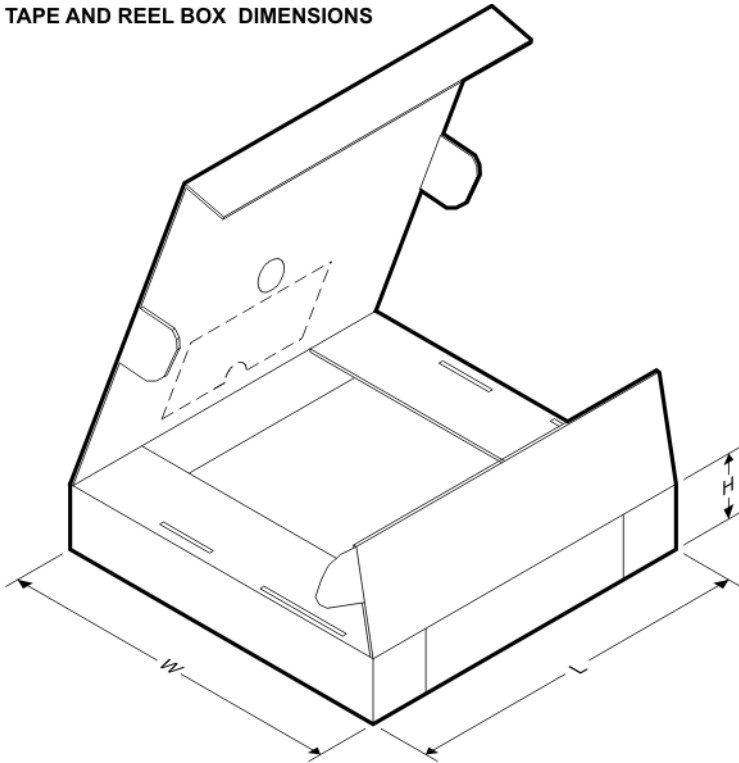
TAPE AND REEL BOX DIMENSIONS

*All dimensions are nominal

Device	Package Type	Package Drawing	Pins	SPQ	Length (mm)	Width (mm)	Height (mm)
ADS7950QDBTRQ1	TSSOP	DBT	30	2000	367.0	367.0	38.0
ADS7951QDBTRQ1	TSSOP	DBT	30	2000	367.0	367.0	38.0
ADS7952QDBTRQ1	TSSOP	DBT	38	2000	367.0	367.0	38.0
ADS7953QDBTRQ1	TSSOP	DBT	38	2000	367.0	367.0	38.0
ADS7954QDBTRQ1	TSSOP	DBT	30	2000	367.0	367.0	38.0
ADS7956QDBTRQ1	TSSOP	DBT	38	2000	367.0	367.0	38.0
ADS7957QDBTRQ1	TSSOP	DBT	38	2000	367.0	367.0	38.0
ADS7958QDBTRQ1	TSSOP	DBT	30	2000	367.0	367.0	38.0
ADS7959QDBTRQ1	TSSOP	DBT	30	2000	367.0	367.0	38.0
ADS7960QDBTRQ1	TSSOP	DBT	38	2000	367.0	367.0	38.0
ADS7961QDBTRQ1	TSSOP	DBT	38	2000	367.0	367.0	38.0

MECHANICAL DATA

DBT (R-PDSO-G38)

PLASTIC SMALL OUTLINE

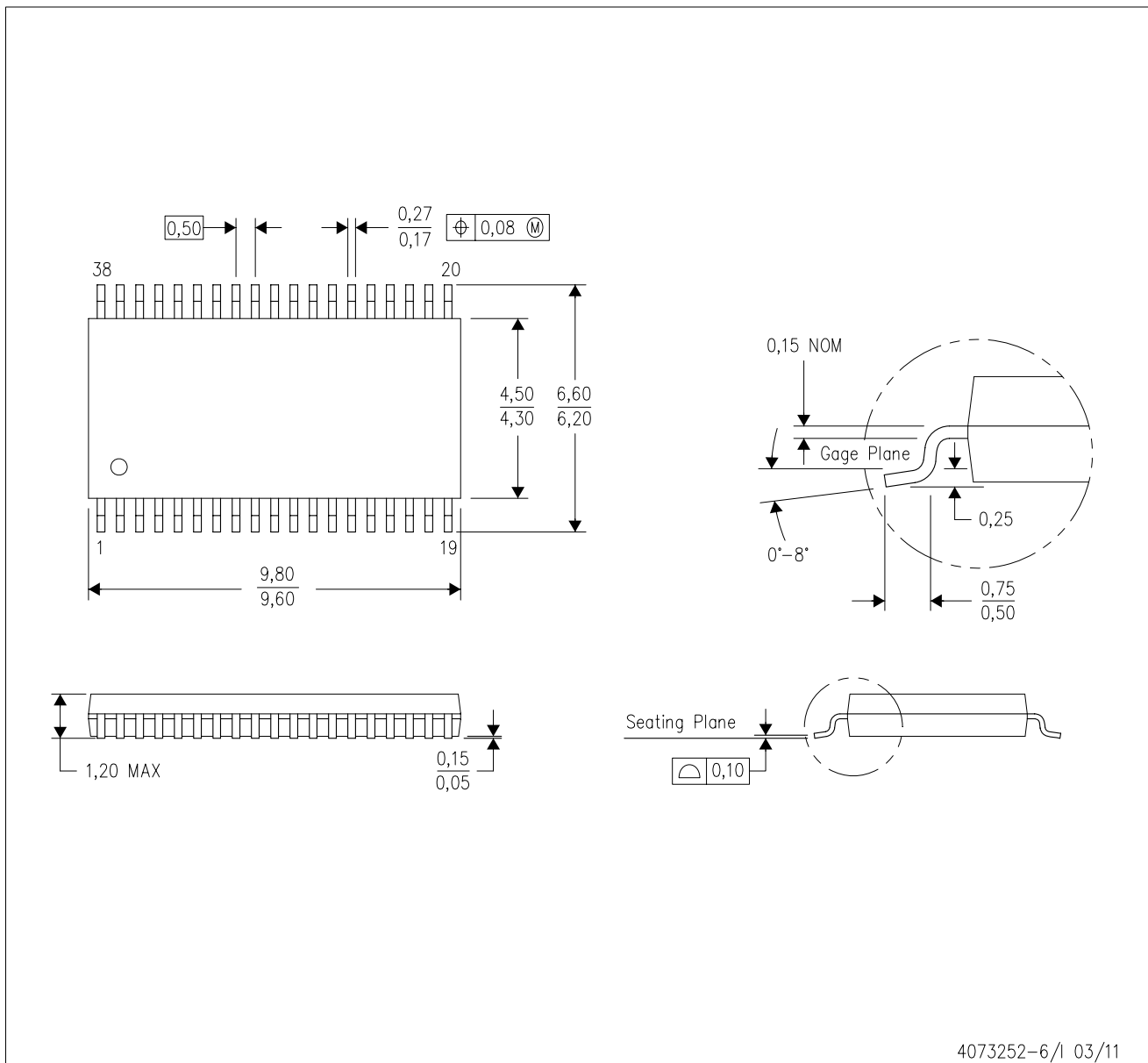

- NOTES:
- All linear dimensions are in millimeters. Dimensioning and tolerancing per ASME Y14.5M-1994.
 - This drawing is subject to change without notice.
 - Body dimensions do not include mold flash or protrusion.
 - Falls within JEDEC MO-153.

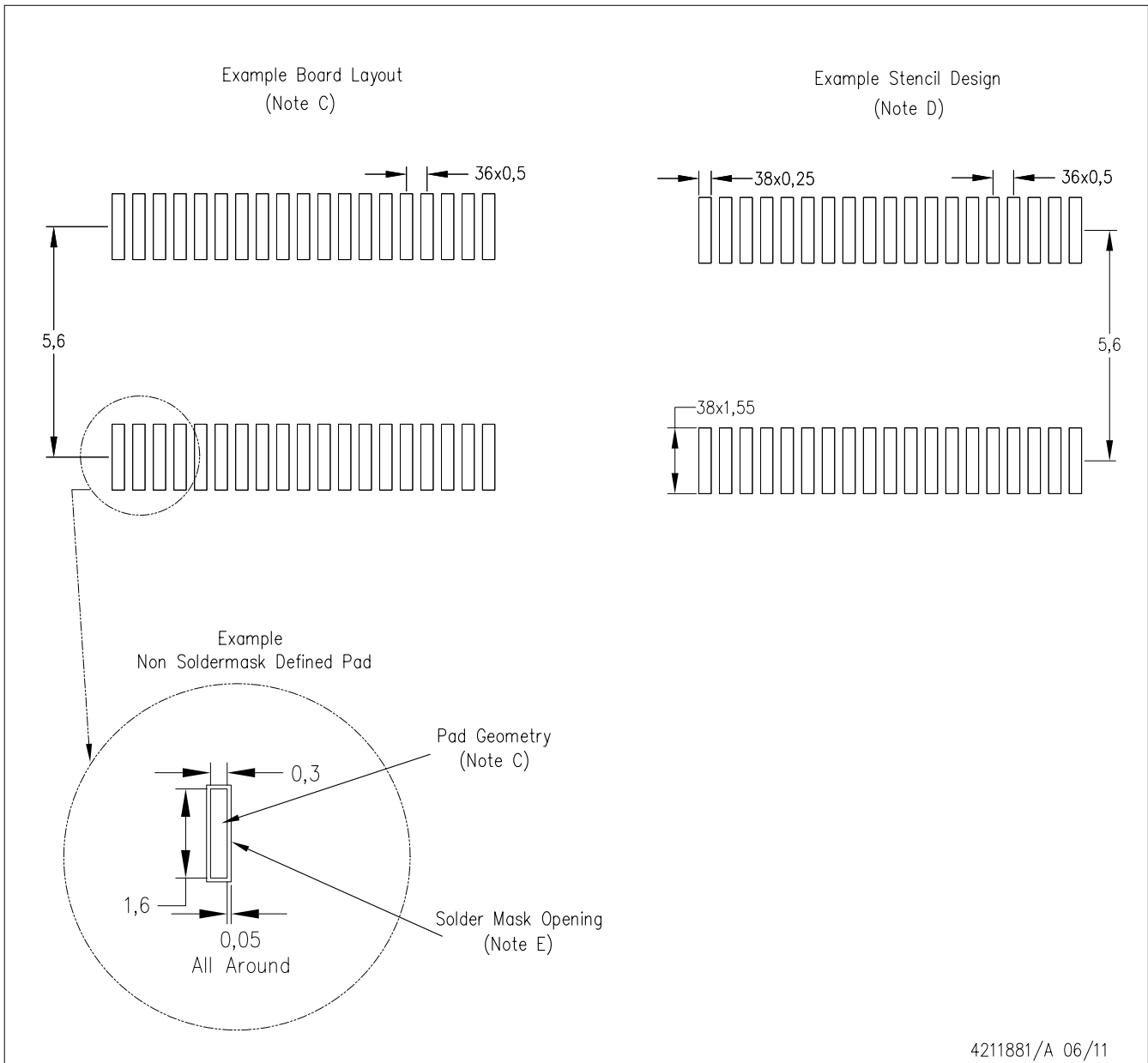

- NOTES:
- A. All linear dimensions are in millimeters.
 - B. This drawing is subject to change without notice.
 - C. Publication IPC-7351 is recommended for alternate designs.
 - D. Laser cutting apertures with trapezoidal walls and also rounding corners will offer better paste release. Customers should contact their board assembly site for stencil design recommendations. Refer to IPC-7525.
 - E. Customers should contact their board fabrication site for solder mask tolerances between and around signal pads.

DBT (R-PDSO-G30)

PLASTIC SMALL OUTLINE

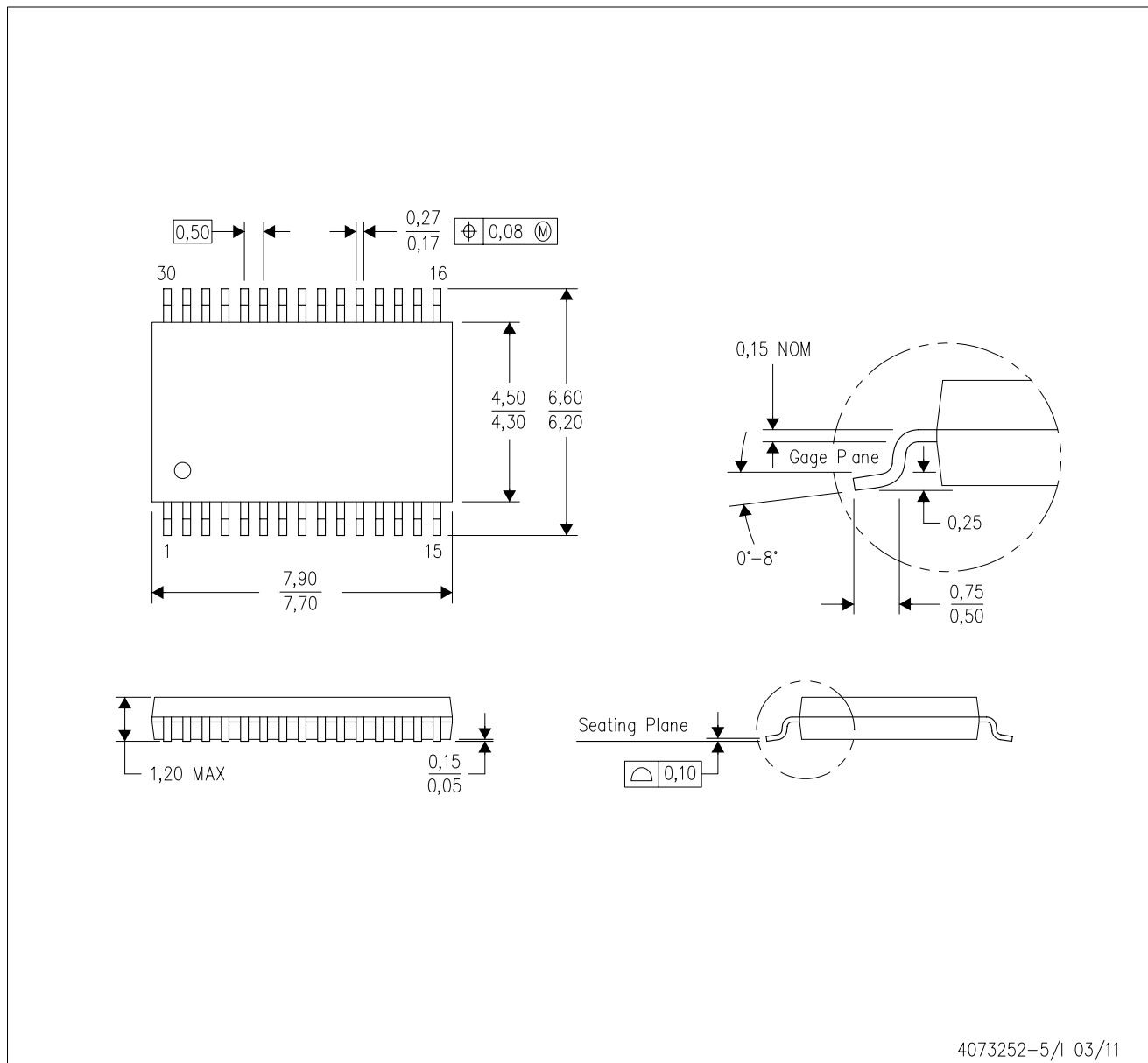

- NOTES:
- A. All linear dimensions are in millimeters. Dimensioning and tolerancing per ASME Y14.5M-1994.
 - B. This drawing is subject to change without notice.
 - C. Body dimensions do not include mold flash or protrusion.
 - D. Falls within JEDEC MO-153.

重要声明和免责声明

TI 均以“原样”提供技术性及其可靠性数据（包括数据表）、设计资源（包括参考设计）、应用或其他设计建议、网络工具、安全信息和其他资源，不保证其中不含任何瑕疵，且不做任何明示或暗示的担保，包括但不限于对适销性、适合某特定用途或不侵犯任何第三方知识产权的暗示担保。

所述资源可供专业开发人员应用TI 产品进行设计使用。您将对以下行为独自承担全部责任：(1) 针对您的应用选择合适的TI 产品；(2) 设计、验证并测试您的应用；(3) 确保您的应用满足相应标准以及任何其他安全、安保或其他要求。所述资源如有变更，恕不另行通知。TI 对您使用所述资源的授权仅限于开发资源所涉及TI 产品的相关应用。除此之外不得复制或展示所述资源，也不提供其它TI 或任何第三方的知识产权授权许可。如因使用所述资源而产生任何索赔、赔偿、成本、损失及债务等，TI 对此概不负责，并且您须赔偿由此对TI 及其代表造成的损害。

TI 所提供产品均受TI 的销售条款 (<http://www.ti.com.cn/zh-cn/legal/termsofsale.html>) 以及ti.com.cn上或随附TI产品提供的其他可适用条款的约束。TI提供所述资源并不扩展或以其他方式更改TI 针对TI 产品所发布的可适用的担保范围或担保免责声明。

邮寄地址：上海市浦东新区世纪大道 1568 号中建大厦 32 楼，邮政编码：200122
Copyright © 2019 德州仪器半导体技术（上海）有限公司