

2.4-GHz RF FRONT END

Check for Samples: [CC2595](#)

FEATURES

- Low Cost and Small Package
- Very Few External Components
- 2.0-V to 3.6-V Operation
- Less Than 1- μ A Current Consumption in Power Down Mode
- Low Transmit Current Consumption
- 98 mA at 3 V for +20.7 dBm Out (PAE = 40%)
- RoHS Compliant 3- x 3-mm QFN-16 Package

DESCRIPTION

CC2595 is a PA solution that extends the range of any Zigbee or Bluetooth transceiver. It is a cost-effective and high performance RF front end for low-power and low-voltage wireless applications in the 2.4-GHz band. Its single-ended RF input and output make it compatible with any manufacturer's transceiver if appropriate external parts are used. When a transmit/receive (T/R) switch and a balun are used, it can interface with existing and future CC24XX and CC25XX transceiver products. CC2595 extends the link budget by providing a power amplifier for improved output power. It is highly effective for high (+20 dBm) output power making it suitable for battery-operated systems. CC2595 contains PA and RF-matching for simple design of high performance wireless applications. It is packaged in a 3- x 3-mm, 16-lead QFN package with exposed paddle.

FUNCTIONAL BLOCK DIAGRAM

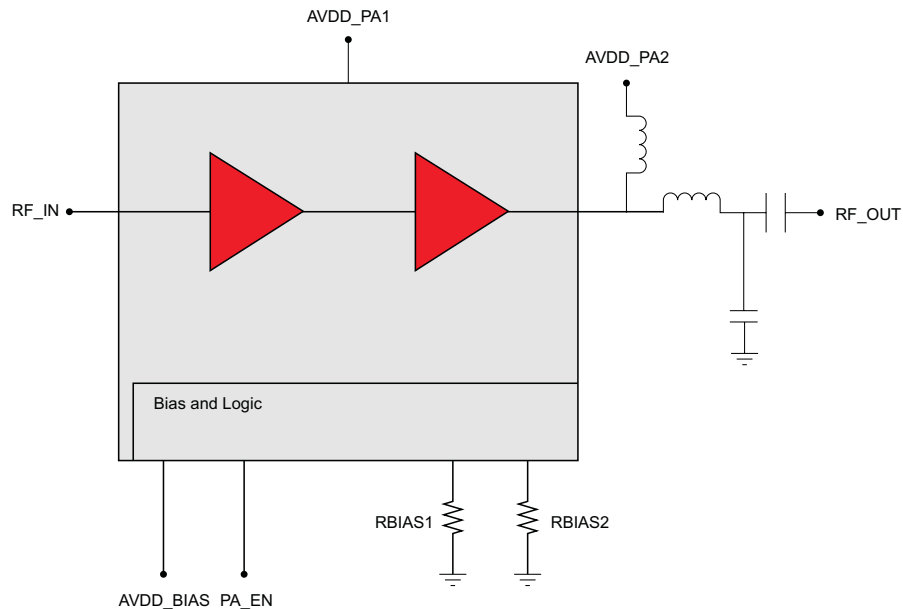

Please be aware that an important notice concerning availability, standard warranty, and use in critical applications of Texas Instruments semiconductor products and disclaimers thereto appears at the end of this data sheet.



This integrated circuit can be damaged by ESD. Texas Instruments recommends that all integrated circuits be handled with appropriate precautions. Failure to observe proper handling and installation procedures can cause damage.

ESD damage can range from subtle performance degradation to complete device failure. Precision integrated circuits may be more susceptible to damage because very small parametric changes could cause the device not to meet its published specifications.

PIN ASSIGNMENTS

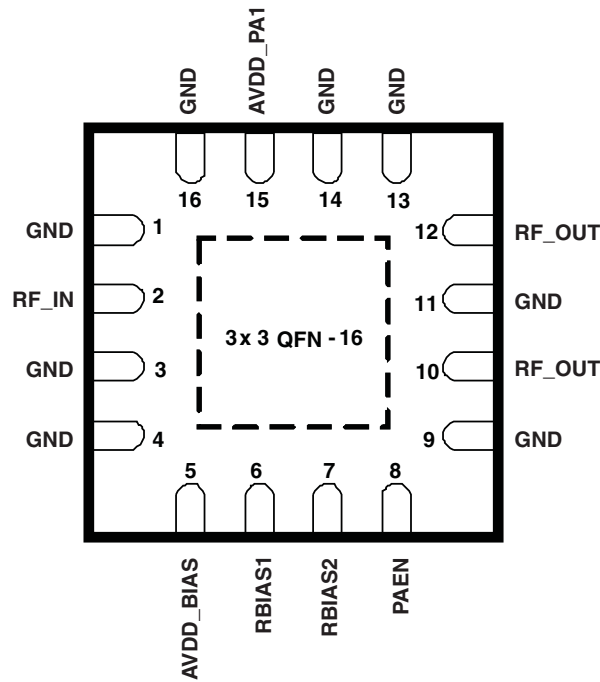

Figure 1. CC2595 Pinout

Table 1. Pin Descriptions for CC2595

PIN NO.	PIN NAME	TYPE	DESCRIPTION
1	GND	GND	
2	RF_IN	RF in/out	RF single-ended input
3	GND	GND	
4	GND	GND	
5	AVDD_BIAS	Power	Supply voltage, analog and logic
6	RBIAS1	Analog	Bias set resistor, stage 1
7	RBIAS2	Analog	Bias set resistor, stage 2
8	PAEN	Digital in	Chip enable: high = PA on
9	GND	GND	
10	RF_OUT	RF in/out	RF single-ended output (1 of 2)
11	GND	GND	
12	RF_OUT	RF in/out	RF single-ended output (2 of 2)
13	GND	GND	
14	GND	GND	
15	AVDD_PA1	Power	Supply voltage, PA stage 1
16	GND	GND	

Table 2. ORDERING INFORMATION⁽¹⁾

T_A	PACKAGE ⁽²⁾	ORDERABLE PART NUMBER	TOP-SIDE MARKING
-40°C to 85°C	RGT (QFN)	CC2595RGTR	C2595

- (1) For the most current package and ordering information, see the Package Option Addendum at the end of this document, or see the TI web site at www.ti.com.
- (2) Package drawings, thermal data, and symbolization are available at www.ti.com/packaging.

ABSOLUTE MAXIMUM RATINGS⁽¹⁾

Over operating free-air temperature range (unless otherwise noted).

		VALUE	UNIT
	Supply voltage range	-0.3 to 3.6	V
	Voltage on any digital pin	-0.3 to $V_{DD} + 0.3$, max 3.6	V
	RF input power RF_IN	+10	dBm
T_{STG}	Storage temperature range	-50 to 150	°C
T_J	Junction temperature	150	°C
ESD	RF pins	HBM (Human Body Model)	1500
	Excluding RF pins		2000

- (1) Stresses beyond those listed under “absolute maximum ratings” may cause permanent damage to the device. These are stress ratings only and functional operation of the device at these or any other conditions beyond those indicated under “recommended operating conditions” is not implied. Exposure to absolute-maximum-rated conditions for extended periods may affect device reliability.

RECOMMENDED OPERATING CONDITIONS

over operating free-air temperature range (unless otherwise noted)

	MIN	NOM	MAX	UNIT
Operating supply voltage	2		3.6	V
T_A Operating free air temperature range	-40		85	°C

ELECTRICAL CHARACTERISTICS
 $T_J = 25^\circ\text{C}$, $V_{DD} = 3\text{ V}$ (unless otherwise specified)

PARAMETER	TEST CONDITIONS	MIN	TYP	MAX	UNIT
Current consumption	No input signal		30		mA
Power down current	EN = LOW			1	μA
High input level (control pin)		1.3		V_{DD}	V
Low input level (control pin)				0.3	V
Power down → Transmit	Time from EN goes HIGH to settled in TX			1	μs

RF CHARACTERISTICS

$T_J = 25^\circ\text{C}$, $V_{DD} = 3\text{ V}$ (unless otherwise specified)

PARAMETER		TEST CONDITIONS	MIN	TYP	MAX	UNIT
f	Frequency range of operation		2400		2483.5	MHz
P_{OUT}	Output power	$P_{in} = 0\text{ dBm}$	+20	+20.7		dBm
PAE	Power added efficiency	$P_{in} = 0\text{ dBm}$		40		%
P_{OUTH}	Output power (high)	$V_{DD} = 3.3\text{ V}$, $P_{in} = +3\text{ dBm}$	+22	+22.5		dBm
PAE_{HI}	Power added efficiency (high)	$V_{DD} = 3.3\text{ V}$, $P_{in} = +3\text{ dBm}$		45		%
P_{1dB}	Output 1-dB compression point			+17		dBm
IRL	Input return loss		10	15		dB
ORL	Output return loss		8	10		dB
	Output power variation over frequency	2400 MHz to 2483.5 MHz		0.5		dB
	Output power variation over supply voltage	2 V to 3.6 V		4		dB
	Output power variation over temperature	-40°C to 85°C		1		dB
	Harmonics	2nd harmonic	The harmonics can be further reduced by using an external LC filter and antenna.			Compliant with international regulatory standards
		3rd harmonic				Compliant with international regulatory standards
K	Stability		Unconditionally stable			
	Load mismatch	No damage at 10:1 VSWR condition; all phases				

TYPICAL CHARACTERISTICS

PA Output Power, PAE, Current Consumption and Gain vs Input Power (3-V Supply)

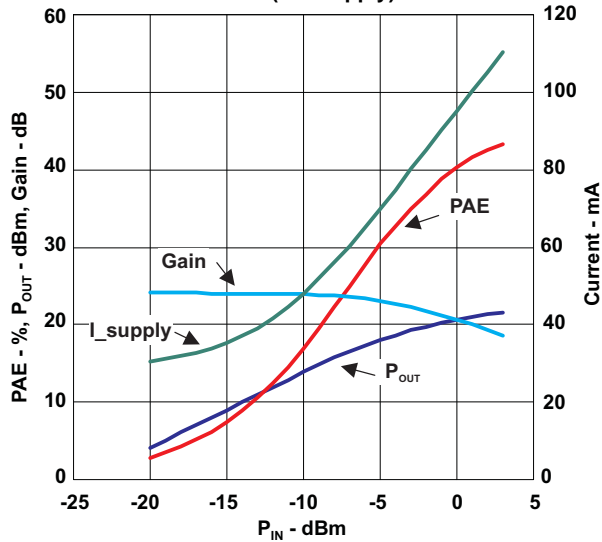

Figure 2.

PA Output Power vs Supply, 0-dBm Input

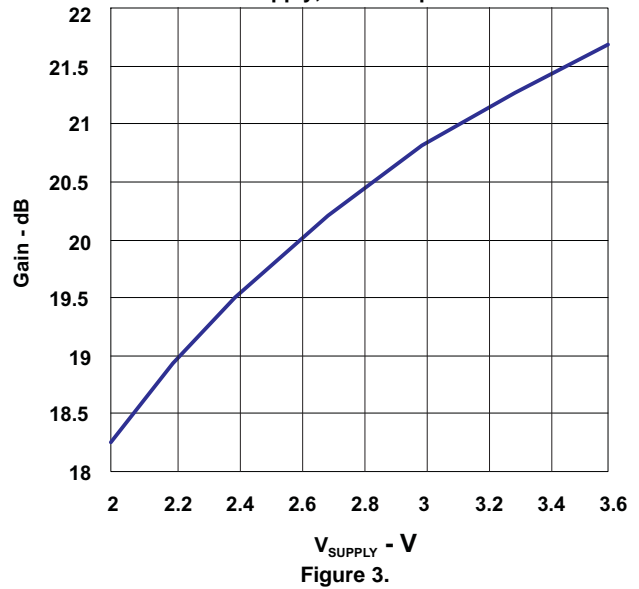

Figure 3.

Noise Figure and Gain vs Frequency (3-V Supply)

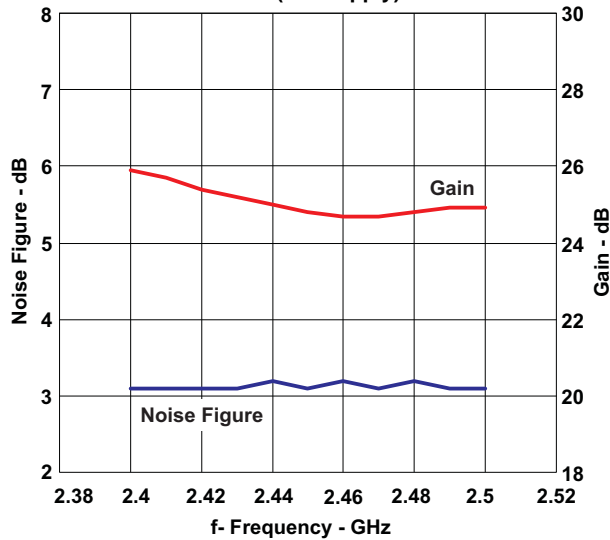

Figure 4.

P_OUT and PAE vs Frequency (3-V Supply, 0-dBm Input and 3.3-V Supply, +3-dBm Input)

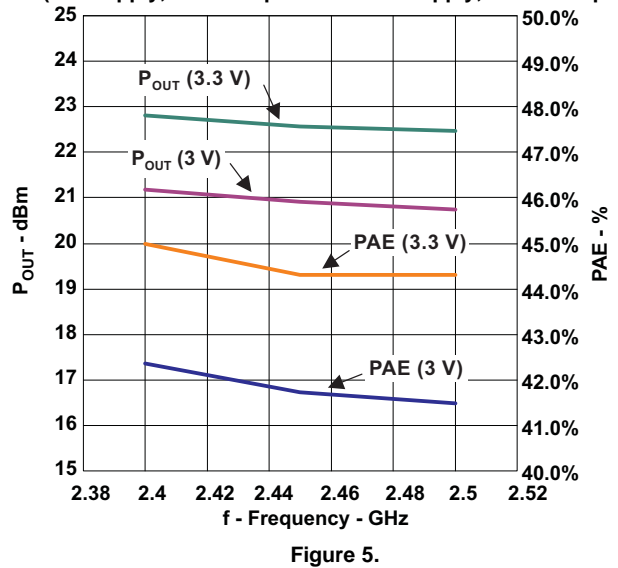

Figure 5.

TYPICAL CHARACTERISTICS (continued)

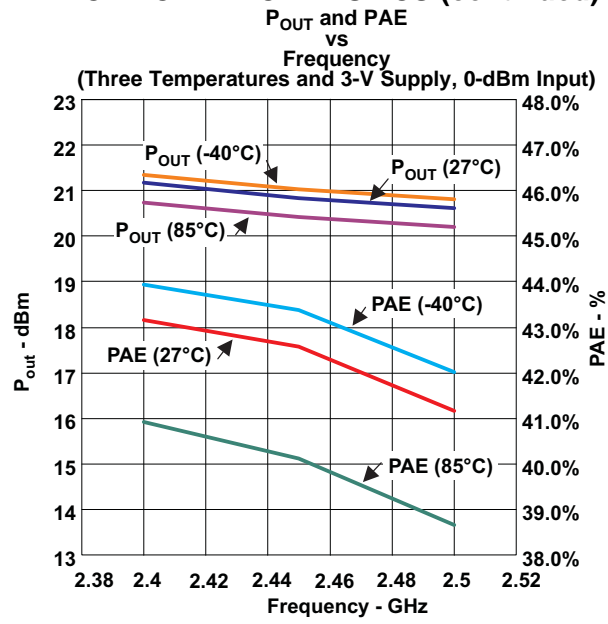

Figure 6.

PACKAGING INFORMATION

Orderable Device	Status (1)	Package Type	Package Drawing	Pins	Package Qty	Eco Plan (2)	Lead/Ball Finish (6)	MSL Peak Temp (3)	Op Temp (°C)	Device Marking (4/5)	Samples
CC2595RGTR	ACTIVE	VQFN	RGT	16	3000	Green (RoHS & no Sb/Br)	CU NIPDAU	Level-2-260C-1 YEAR	-40 to 85	C2595	Samples
CC2595RGTT	ACTIVE	VQFN	RGT	16	250	Green (RoHS & no Sb/Br)	CU NIPDAU	Level-2-260C-1 YEAR	-40 to 85	C2595	Samples

(1) The marketing status values are defined as follows:

ACTIVE: Product device recommended for new designs.

LIFEBUY: TI has announced that the device will be discontinued, and a lifetime-buy period is in effect.

NRND: Not recommended for new designs. Device is in production to support existing customers, but TI does not recommend using this part in a new design.

PREVIEW: Device has been announced but is not in production. Samples may or may not be available.

OBSOLETE: TI has discontinued the production of the device.

(2) **RoHS:** TI defines "RoHS" to mean semiconductor products that are compliant with the current EU RoHS requirements for all 10 RoHS substances, including the requirement that RoHS substance do not exceed 0.1% by weight in homogeneous materials. Where designed to be soldered at high temperatures, "RoHS" products are suitable for use in specified lead-free processes. TI may reference these types of products as "Pb-Free".

RoHS Exempt: TI defines "RoHS Exempt" to mean products that contain lead but are compliant with EU RoHS pursuant to a specific EU RoHS exemption.

Green: TI defines "Green" to mean the content of Chlorine (Cl) and Bromine (Br) based flame retardants meet JS709B low halogen requirements of <=1000ppm threshold. Antimony trioxide based flame retardants must also meet the <=1000ppm threshold requirement.

(3) MSL, Peak Temp. - The Moisture Sensitivity Level rating according to the JEDEC industry standard classifications, and peak solder temperature.

(4) There may be additional marking, which relates to the logo, the lot trace code information, or the environmental category on the device.

(5) Multiple Device Markings will be inside parentheses. Only one Device Marking contained in parentheses and separated by a "~" will appear on a device. If a line is indented then it is a continuation of the previous line and the two combined represent the entire Device Marking for that device.

(6) Lead/Ball Finish - Orderable Devices may have multiple material finish options. Finish options are separated by a vertical ruled line. Lead/Ball Finish values may wrap to two lines if the finish value exceeds the maximum column width.

Important Information and Disclaimer:The information provided on this page represents TI's knowledge and belief as of the date that it is provided. TI bases its knowledge and belief on information provided by third parties, and makes no representation or warranty as to the accuracy of such information. Efforts are underway to better integrate information from third parties. TI has taken and continues to take reasonable steps to provide representative and accurate information but may not have conducted destructive testing or chemical analysis on incoming materials and chemicals. TI and TI suppliers consider certain information to be proprietary, and thus CAS numbers and other limited information may not be available for release.

In no event shall TI's liability arising out of such information exceed the total purchase price of the TI part(s) at issue in this document sold by TI to Customer on an annual basis.

TAPE AND REEL INFORMATION

QUADRANT ASSIGNMENTS FOR PIN 1 ORIENTATION IN TAPE

*All dimensions are nominal

Device	Package Type	Package Drawing	Pins	SPQ	Reel Diameter (mm)	Reel Width W1 (mm)	A0 (mm)	B0 (mm)	K0 (mm)	P1 (mm)	W (mm)	Pin1 Quadrant
CC2595RGTR	VQFN	RGT	16	3000	330.0	12.4	3.3	3.3	1.1	8.0	12.0	Q2
CC2595RGTT	VQFN	RGT	16	250	180.0	12.4	3.3	3.3	1.1	8.0	12.0	Q2

TAPE AND REEL BOX DIMENSIONS

*All dimensions are nominal

Device	Package Type	Package Drawing	Pins	SPQ	Length (mm)	Width (mm)	Height (mm)
CC2595RGTR	VQFN	RGT	16	3000	350.0	350.0	43.0
CC2595RGTT	VQFN	RGT	16	250	210.0	185.0	35.0

RGT 16

GENERIC PACKAGE VIEW

VQFN - 1 mm max height

PLASTIC QUAD FLATPACK - NO LEAD

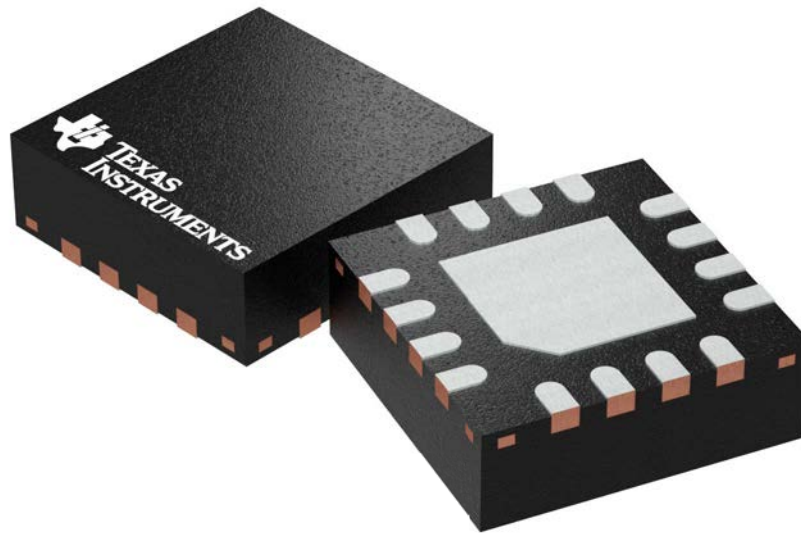

Images above are just a representation of the package family, actual package may vary.
Refer to the product data sheet for package details.

4203495/1

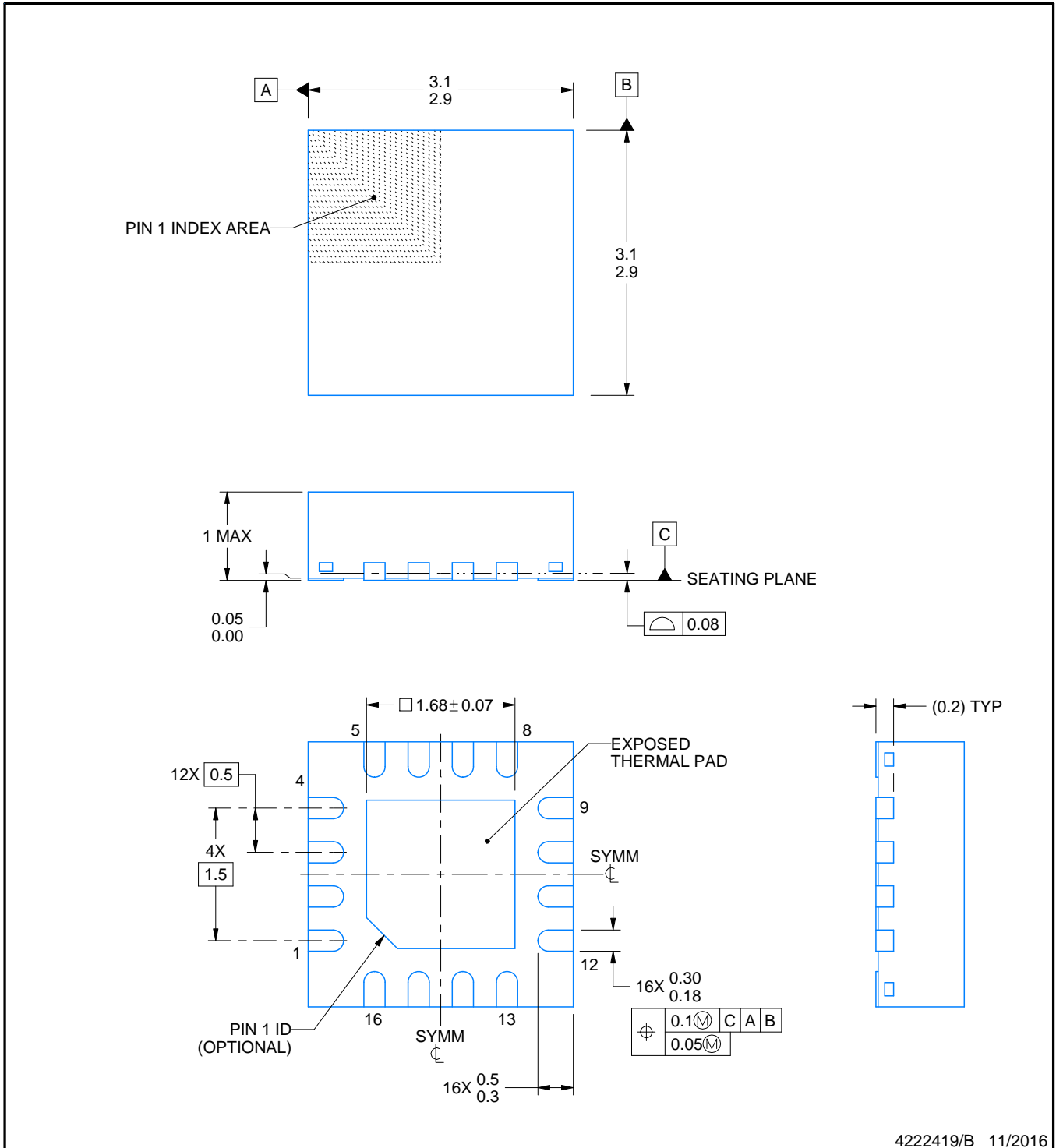
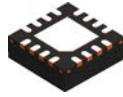

4222419/B 11/2016

NOTES:

1. All linear dimensions are in millimeters. Any dimensions in parenthesis are for reference only. Dimensioning and tolerancing per ASME Y14.5M.
2. This drawing is subject to change without notice.
3. The package thermal pad must be soldered to the printed circuit board for thermal and mechanical performance.

EXAMPLE STENCIL DESIGN

RGT0016C

VQFN - 1 mm max height

PLASTIC QUAD FLATPACK - NO LEAD

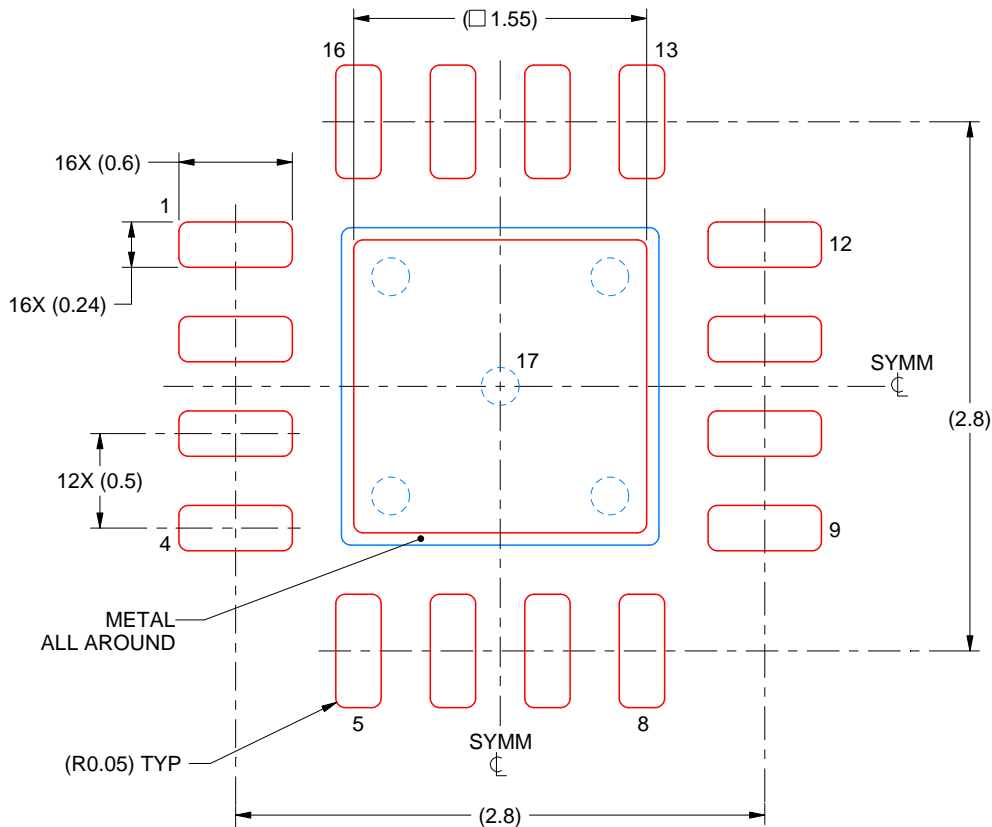

SOLDER PASTE EXAMPLE
BASED ON 0.125 mm THICK STENCIL

EXPOSED PAD 17:
85% PRINTED SOLDER COVERAGE BY AREA UNDER PACKAGE
SCALE:25X

4222419/B 11/2016

NOTES: (continued)

6. Laser cutting apertures with trapezoidal walls and rounded corners may offer better paste release. IPC-7525 may have alternate design recommendations.

IMPORTANT NOTICE AND DISCLAIMER

TI PROVIDES TECHNICAL AND RELIABILITY DATA (INCLUDING DATASHEETS), DESIGN RESOURCES (INCLUDING REFERENCE DESIGNS), APPLICATION OR OTHER DESIGN ADVICE, WEB TOOLS, SAFETY INFORMATION, AND OTHER RESOURCES "AS IS" AND WITH ALL FAULTS, AND DISCLAIMS ALL WARRANTIES, EXPRESS AND IMPLIED, INCLUDING WITHOUT LIMITATION ANY IMPLIED WARRANTIES OF MERCHANTABILITY, FITNESS FOR A PARTICULAR PURPOSE OR NON-INFRINGEMENT OF THIRD PARTY INTELLECTUAL PROPERTY RIGHTS.

These resources are intended for skilled developers designing with TI products. You are solely responsible for (1) selecting the appropriate TI products for your application, (2) designing, validating and testing your application, and (3) ensuring your application meets applicable standards, and any other safety, security, or other requirements. These resources are subject to change without notice. TI grants you permission to use these resources only for development of an application that uses the TI products described in the resource. Other reproduction and display of these resources is prohibited. No license is granted to any other TI intellectual property right or to any third party intellectual property right. TI disclaims responsibility for, and you will fully indemnify TI and its representatives against, any claims, damages, costs, losses, and liabilities arising out of your use of these resources.

TI's products are provided subject to TI's Terms of Sale (www.ti.com/legal/termsofsale.html) or other applicable terms available either on ti.com or provided in conjunction with such TI products. TI's provision of these resources does not expand or otherwise alter TI's applicable warranties or warranty disclaimers for TI products.

Mailing Address: Texas Instruments, Post Office Box 655303, Dallas, Texas 75265
Copyright © 2019, Texas Instruments Incorporated