

REVISIONS				
ZONE	REV.	DESCRIPTION	DATE	APPROVED
	A1	ORIGINAL RELEASE	05/01/16	<i>[Signature]</i>

**DESCRIPTION:**

PMI Model A-3D-005080-18-13P is an ultra wide bandwidth low noise amplifier. It is unconditionally stable over operating temperature. The amplifier is DC voltage regulated and reverse voltage polarity protected internally.

**SPECIFICATIONS AT +23 °C UNLESS OTHERWISE INDICATED:**

- Frequency Range: ..... 0.5 to 8.0 GHz
- Gain: ..... 33 dB min.
- Pass Band Flatness: ..... ±1.5 dB max. peak to peak
- Noise Figure: ..... 1.8 dB max.
- VSWR In: ..... 2.0 : 1 max. (Input DC coupled)
- VSWR In: ..... 2.5 : 1 max. (Input AC coupled)
- VSWR Out: ..... 2.0 : 1 max.
- P1dB Out: ..... 13.0 dBm min.
- DC Power Supply: ..... +12 VDC @ 150 mA nominal
- Connectors (In/Out): ..... SMA female, field replaceable
- Finish: ..... Gold plated

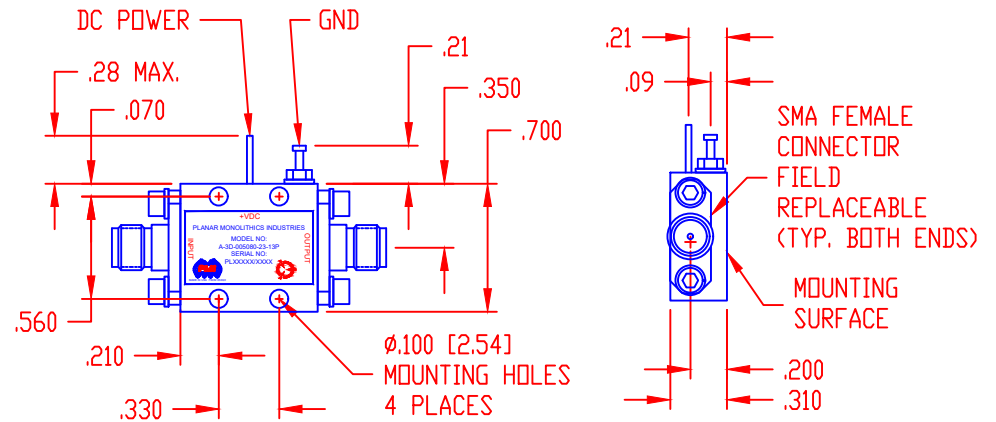
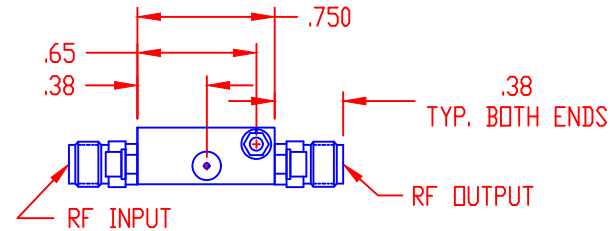

**ENVIRONMENTAL RATINGS**

- **TEMPERATURE:** ..... -55°C TO + 85°C (OPERATING)  
..... -65°C TO +125°C (STORAGE)
- **HUMIDITY:** ..... MIL-STD-202F, METHOD 103B COND. B
- **SHOCK:** ..... MIL-STD-202F, METHOD 213B COND. B
- **VIBRATION:** ..... MIL-STD-202F, METHOD 204D COND. B
- **ALTITUDE:** ..... MIL-STD-202F, METHOD 105C COND. B
- **TEMPERATURE CYCLE:** ..... MIL-STD-202F, METHOD 107D COND. A

NOTES: 1: SPECIFICATIONS WILL VARY OVER OPERATING TEMPERATURE  
2: THE ABOVE SPECIFICATIONS ARE SUBJECT TO CHANGE OR REVISION

UNLESS OTHERWISE SPECIFIED  
ALL DIMENSIONS ARE IN INCHES  
TOLERANCES:  
X.XX ±0.01  
X.XXX ±0.005

**PMI CONFIDENTIAL AND PROPRIETARY**

**PLANAR MONOLITHICS INDUSTRIES, INC.**  
7311-F GROVE ROAD  
FREDERICK, MARYLAND 21704 USA  
TEL: 301-662-5019 FAX: 301-662-1731  
WEBSITE: [www.pmi-rf.com](http://www.pmi-rf.com)  
E-MAIL: [sales@pmi-rf.com](mailto:sales@pmi-rf.com)  
ISO 9001:2008 CERTIFIED



APPROVALS		DATE	TITLE	
<i>[Signature]</i>		05.05.16	PRODUCT FEATURE	
DRAWN			A-3D-005080-18-13P	
CHECKED		SIZE	FSCM NO.	DWG NO.
		A	05XQ0	D3-3A
ISSUED		SCALE	N:S	SHEET 1 OF 1
				REV. A1