



F-Band Noise Figure and Gain Test Extenders

Description:

Model STG-08-S1 is a full F-Band noise figure and gain test extender that extends the noise and gain measurement capabilities of common and low frequency signal synthesizers and noise figure meters to the frequency range of 90 to 140 GHz. This extender is designed to interface with industry standard noise and gain test systems, such as Keysight 8970A/B, N8973A, and N8975A/B. It can also interface with any noise and gain analyzers in the 10.0 MHz to 1.6 GHz frequency range.



Features:

- Full Band Coverage
- Precision Calibrated ENR
- Great ENR and Gain Flatness

Applications:

- Test Lab
- Instrumentations

Electrical Specifications:

Parameter	Minimum	Typical	Maximum
RF Frequency	90 GHz		140 GHz
Noise Source ENR		12 dB	
Noise Source Bias Voltage/Current	+18 V _{DC} /50 mA	+28 V _{DC} /60 mA	+30 V _{DC} /75 mA
Down Converter IF Frequency	10.0 MHz		1.6 GHz
Down Converter LO Frequency/Power	10.0 GHz/+3 dBm	12.7 GHz/+5 dBm	15.5 GHz/+20 dBm
Down Converter LO Damage Level			+20 dBm
Down Converter RF Damage Level			+15 dBm
Down Converter Noise Figure		15 dB	
Down Converter Gain		20 dB	
Down Converter Bias Voltage	+8 V _{DC}	+12 V _{DC}	+15 V _{DC}
Down Converter Bias Current		450 mA	
Specification Temperature		+25 °C	
Operating Temperature	0 °C		+50 °C

Mechanical Specifications:

Item	Specification
Noise Source RF Port	WR-08 Waveguide with UG-387/U-M Flange
Noise Source Bias Port	BNC (F)
Noise Source Trigger	SMA (F)
Down Converter RF Port	WR-08 Waveguide with UG-387/U-M Flange
Down Converter LO Port	SMA (F)
Down Converter IF Port	SMA (F)
Down Converter Bias Port	Banana Jack
Weight	4.0 lbs
Outline	TG-F





F-Band Noise Figure and Gain Test Extenders

Mechanical Outline (Unless otherwise specified, all dimensions are in inches[millimeters])

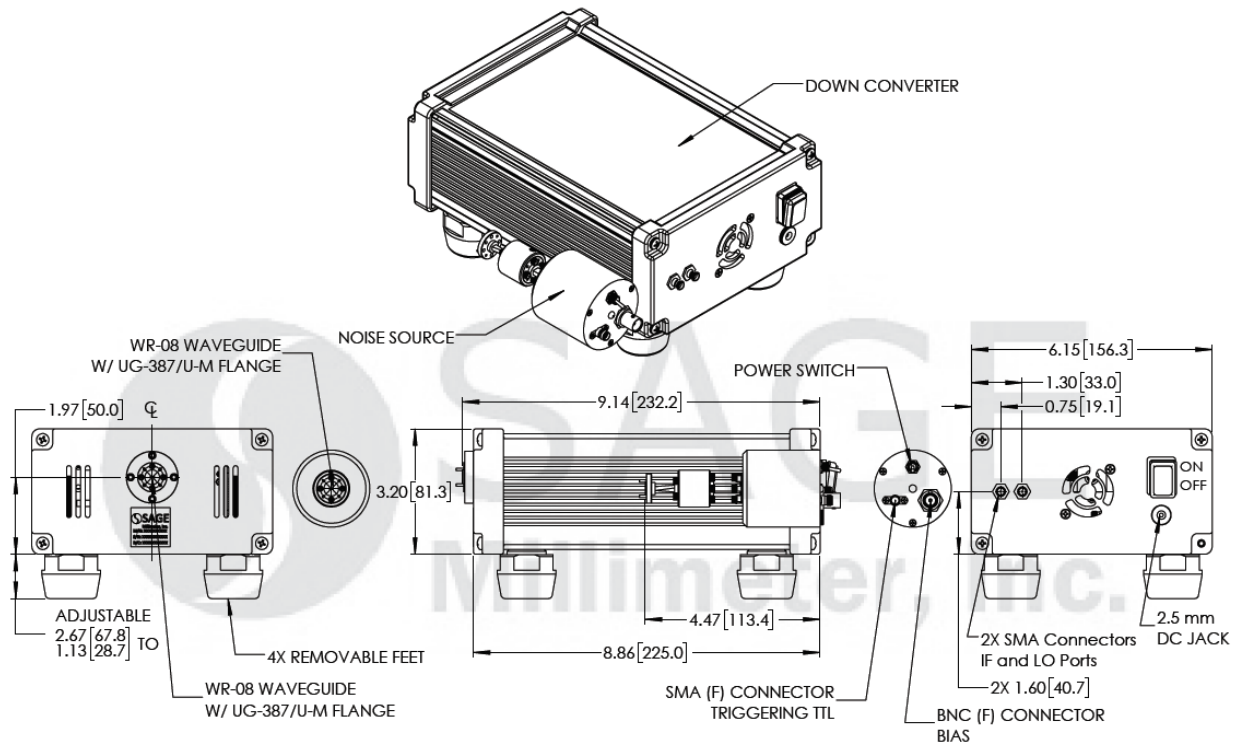

Outline of Noise Source (STZ-08-I1)

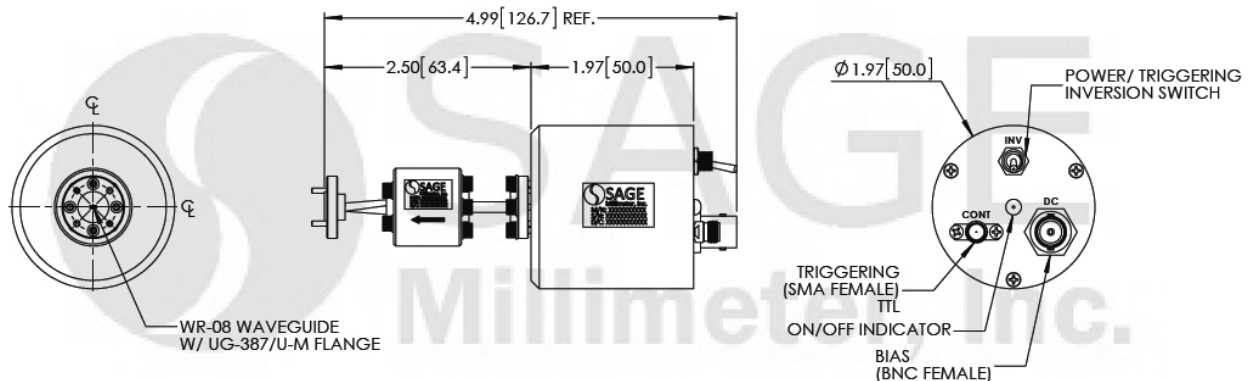

Note:

- All data presented is collected from a sample lot. Actual data may vary unit to unit.
- All testing was performed under +25°C case temperature.
- The **Triggering Port** (female SMA connector) of the noise source is provided to turn the noise source on and off via a TTL control signal any time the **Bias** is applied. The switching frequency is limited to 1 KHz.



F-Band Noise Figure and Gain Test Extenders

- The **Power/Triggering Inversion Switch** of the noise source is provided to manually turn the noise source on and off any time the **Bias** is applied. When the switch is in the “ON” position, the LED light will be illuminated.
- SAGE Millimeter, Inc. reserves the right to change the information presented without notice.

Caution:

- Exceeding absolute maximum ratings shown will damage the device.
- Any foreign objects in the waveguide will cause performance degradation and possible device damage.

