



V-Band Full Waveguide Band Down-Converter

Description:

Model STC-20-15-S1 is a V-Band down-converter that converts millimeterwave signals from a frequency range of 50 to 75 GHz to the baseband at 10 MHz to 1.6 GHz. The down-converter requires 12.5 to 18.75 GHz at 0 dBm input power, which can be obtained from a standard 20 GHz synthesizer. The down-converter has low harmonic levels and excellent gain flatness, making it a good candidate to extend low frequency test equipment for millimeterwave testing purposes.



Features:

- Full Band Coverage
- Good Gain Flatness

Applications:

- Test Lab
- Instrumentations
- Auto Test Set

Electrical Specifications:

Parameter	Minimum	Typical	Maximum
RF Input Frequency	50 GHz		75 GHz
IF Frequency Output	10.0 MHz		1.6 GHz
LO Input Frequency	12.5 GHz		18.75 GHz
LO Power	+3 dBm	+5 dBm	+20 dBm
Conversion Gain		20 dB	
Noise Figure		12 dB	
Harmonic Suppression		20 dB	
LO Damage Level			+20 dBm
RF Damage Level			+15 dBm
DC Bias	+8 V _{DC}	+12 V _{DC}	+16 V _{DC}
DC Current		450 mA	750 mA
Specification Temperature		+25 °C	
Operating Temperature	0 °C		+50 °C

Mechanical Specifications:

Port	Connector
RF Port	WR-15 Waveguide with UG385/U Flange
LO Port	SMA (F)
IF Port	SMA (F)
Bias Port	Banana Jack
Finish	Black Anodized
Weight	3.5 lb
Size	6.15" (W) x 8.86" (L) x 3.20" to 5.82" (H)
Outline	TC-V



www.sagemillimeter.com | 3043 Kashiwa Street, Torrance, CA 90505
 Phone: 424-757-0168 | Fax: 424-757-0188 | Email: sales@sagemillimeter.com



V-Band Full Waveguide Band Down-Converter

Typical Gain vs. Frequency

IF: 1 GHz, LO: +0 dBm, RF: -50 dBm

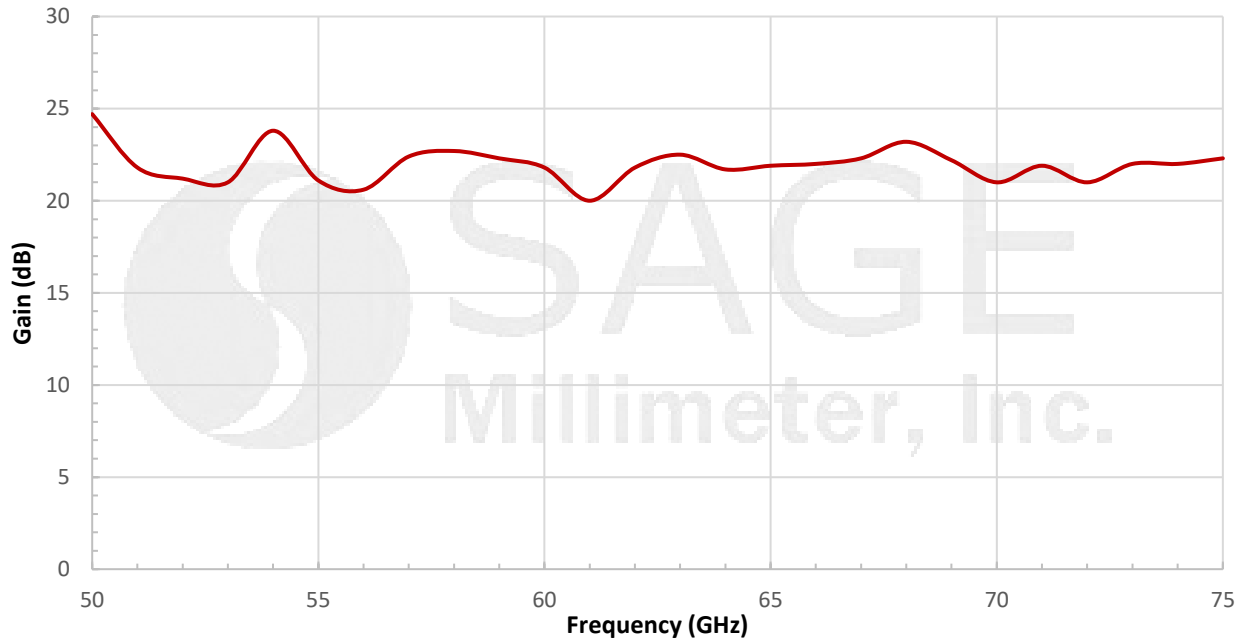

Mechanical Outline: (Unless otherwise specified, all dimensions are in inches[millimeters])

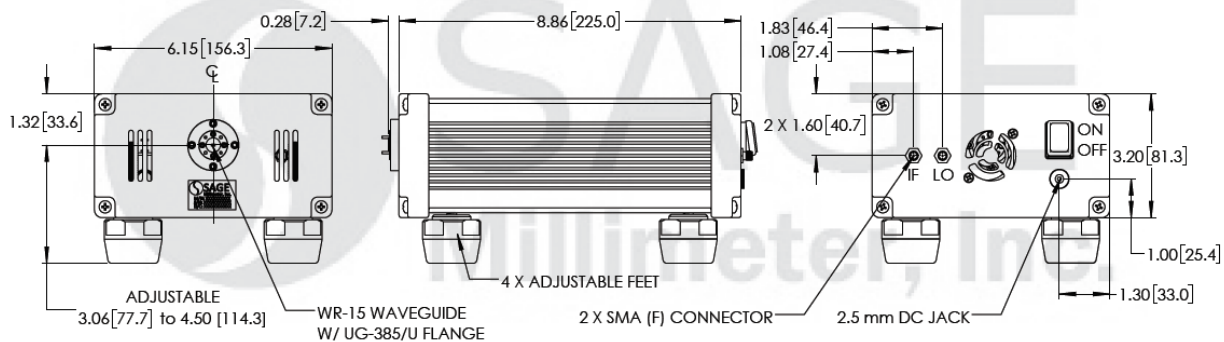

Note:

- All data presented is collected from a sample lot. Actual data may vary unit to unit, slightly.
- All testing was performed under +25 °C case temperature.
- SAGE Millimeter, Inc. reserves the right to change the information presented without notice.

Caution:

- Exceeding absolute maximum ratings of the device will damage the device.
- Proper torque, 8.0 ± 0.15 inch-pounds (0.92 ± 0.05 Nm), should be applied. **SAGE Millimeter torque wrench, model SCH-08008-S1, is highly recommended.**
- Any foreign objects in the waveguide will cause performance degradation or damage the device.



www.sagemillimeter.com | 3043 Kashiwa Street, Torrance, CA 90505
 Phone: 424-757-0168 | Fax: 424-757-0188 | Email: sales@sagemillimeter.com