



E-Band Programmable Attenuator, High Precision, 70 dB Attenuation

Description:

Model STA-60-12-P8 is an instrumentation grade, high precision and high attenuation range motorized programmable attenuator for use in millimeterwave systems across the standard E-band frequency range of 60 to 90 GHz. The attenuation control and power interface is an integrated and pre-configured Lantronix Xport AR device with an Ethernet port (RJ45) which is used to accommodate remote operations from 0 to 60 dB and up to 70 dB attenuation value. The attenuator can be accurately controlled with the increments of 0.1 dB between 0 and 40 dB and 0.2 dB between 40 and 50 dB. Above 50 dB, the control is realized by using the STEPS feature and the attenuation value is for reference only (see manual for more details). To operate remotely, download the 'DeviceInstaller' program and firmware from Lantronix onto a local computer. The attenuator is powered and controlled with a PoE enabled Ethernet cord via the Ethernet cable provided.



Features:

- Full Waveguide Band Coverage
- Power and Control via PoE Ethernet Port
- High Attenuation Accuracy
- Higher Attenuation Range up to 70 dB
- Waveguide Moding Free

Applications:

- Test Lab
- Automated Test Equipment
- Bit Error Rate Testing
- Fade Margin
- Transceiver Diversity

Electrical Specifications:

Parameter	Minimum	Typical	Maximum
RF Frequency Range	60 GHz		90 GHz
Insertion Loss		1.0 dB	1.3 dB
Attenuation Range	0 dB		60 dB +
Attenuation Accuracy	Better than 0.1 dB or 2% of reading, whichever is bigger up to 50 dB		
Return Loss			23 dB
Operating Voltage (DC)	3.3 V _{DC} (Power Over Ethernet Port)		
Power Handling*		50 mW (CW)	100 mW (CW)
Specification Temperature		+25 °C	
Operating Temperature	+ 5 °C		+35 °C

*Note: The maximum power handling is based on a pulsed signal operation. Limit to 100 mW for CW operation.

Mechanical Specifications:

Port	Connector
RF Ports	WR-12 Waveguide with UG-387/U Flange
Control/Power Interface	Cat 5, Ethernet (RJ45)
Finish	Gold Plated Waveguide Flange; Black Painted Body
Weight	37.5 Oz [1,065 grams]
Insertion Length	3.5" [89 mm]
Outline	TA-PE-F1



www.sagemillimeter.com | 3043 Kashiwa Street, Torrance, CA 90505
 Phone: 424-757-0168 | Fax: 424-757-0188 | Email: sales@sagemillimeter.com



E-Band Programmable Attenuator, High Precision, 70 dB Attenuation

Typical Attenuation vs. Frequency

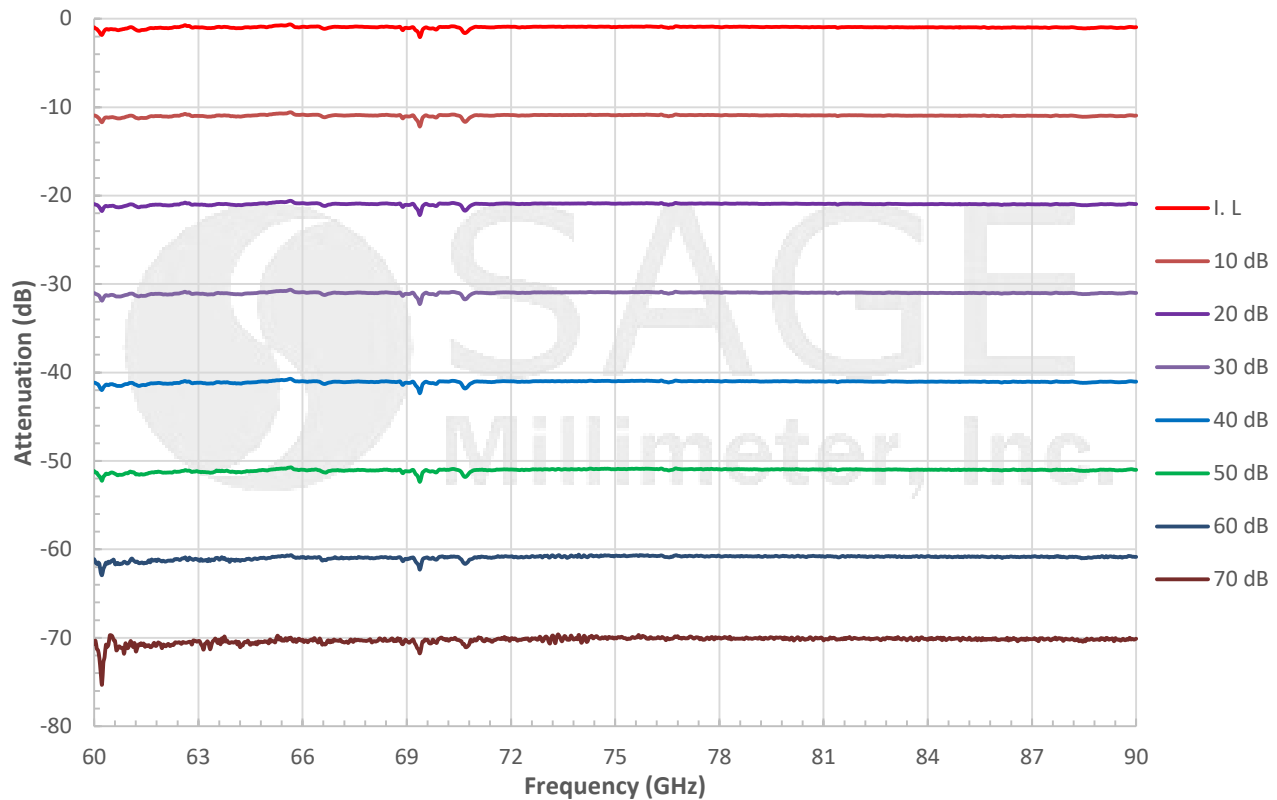

Mechanical Outline: (Unless otherwise specified, all dimensions are in inches [millimeters])

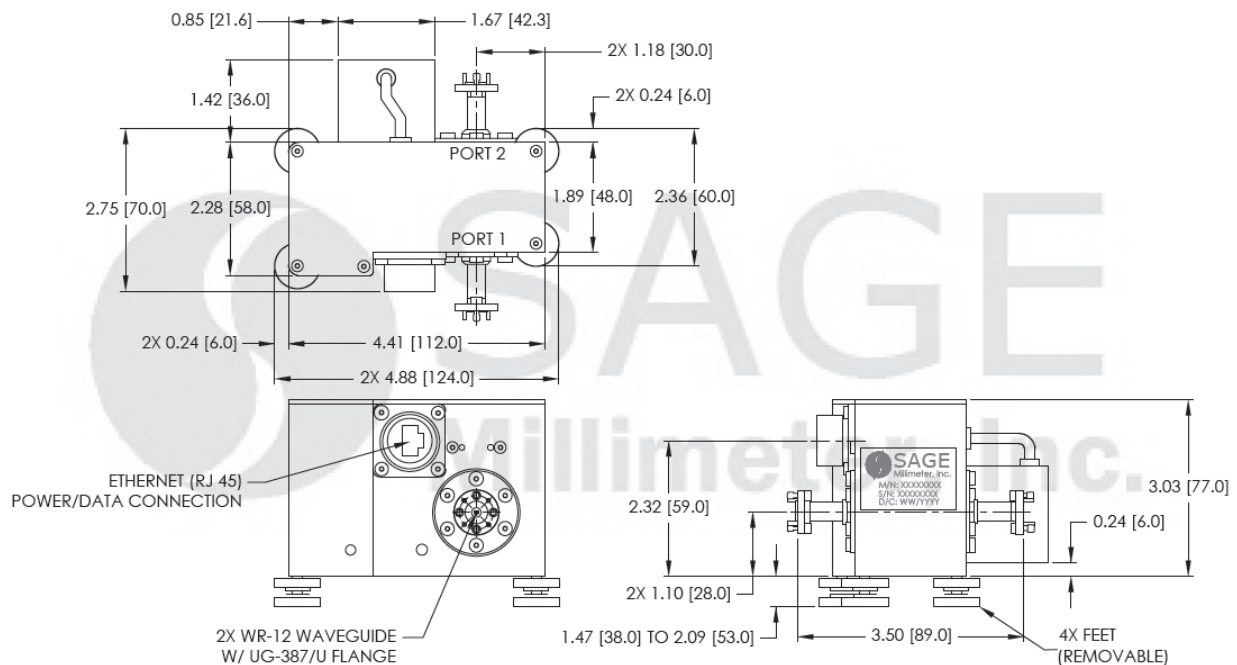

www.sagemillimeter.com | 3043 Kashiwa Street, Torrance, CA 90505
 Phone: 424-757-0168 | Fax: 424-757-0188 | Email: sales@sagemillimeter.com



E-Band Programmable Attenuator, High Precision, 70 dB Attenuation

Note:

- Calibration accuracy is 0.1 dB or 2% better of the reading, whichever is greater, for attenuation ranges up to 50 dB and “for reference only” up to 70 dB. Customer may perform the self-calibration over 50 dB for its application defined accuracy needs.
- Data above 50 dB was taken using STEPS reference command. **(See user’s manual for detailed instructions)**
- The phase shift value does change while varying the attenuation.
- All data presented is collected from a sample lot. Actual data may vary unit to unit slightly.
- All testing was performed under +25 °C case temperature.
- SAGE Millimeter, Inc. reserves the right to change the information presented without notice.

Caution:

- Exceeding absolute maximum ratings shown will damage the device.
- Any foreign objects in the waveguide will cause performance degradation and may damage the device.

