



8-Way Coaxial Power Splitter, 26.5 to 40 GHz

Description:

Model SCS-2734032516-KFKF-82 is a coaxial 8-way power splitter with a typical insertion loss of 2.5 dB at each output port and a typical isolation of 16 dB across the frequency range of 26.5 to 40 GHz. The power splitter has a nominal power handling of 30 W (CW) and a typical amplitude unbalance of ± 0.8 dB. The return loss for all ports is 10 dB typical. The RF connectors of the power splitter are female 2.92 mm (K) connectors.



Features:

- Low Insertion Loss
- High Isolation
- Compact Package

Applications:

- Test Lab
- Sub-assemblies
- Test Instrumentation

Electrical Specifications:

Parameter	Minimum	Typical	Maximum
Frequency Range	26.5 GHz		40 GHz
Insertion Loss		2.5 dB	
Amplitude Unbalance		± 0.8 dB	
Phase Unbalance		$\pm 8.0^\circ$	
Port Isolation		16 dB	
Return Loss		10 dB	
Forward Power Handling			30 W (CW)
Reverse Power Handling			2 W (CW)
Impedance		50 Ohms	
Specification Temperature		+25 °C	
Operating Temperature	-35 °C		+80 °C

Mechanical Specifications:

Item	Parameter
RF Connectors	2.92 mm (F)
Case Material	Aluminum
Finish	Black Paint
Size	4.10" (L) x 1.58" (W) x 0.39" (H)
Outline	CS-K8-SR1



8-Way Coaxial Power Splitter, 26.5 to 40 GHz

Typical Performance vs. Frequency

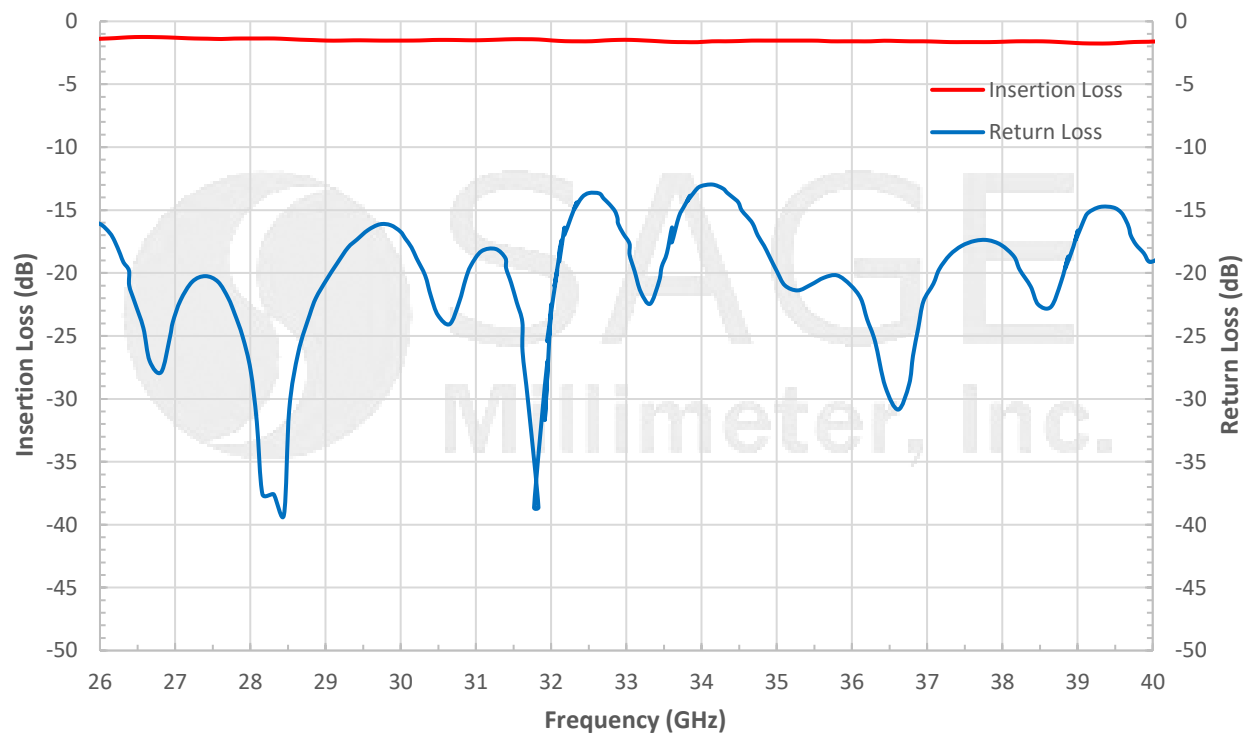

Typical Isolation vs. Frequency

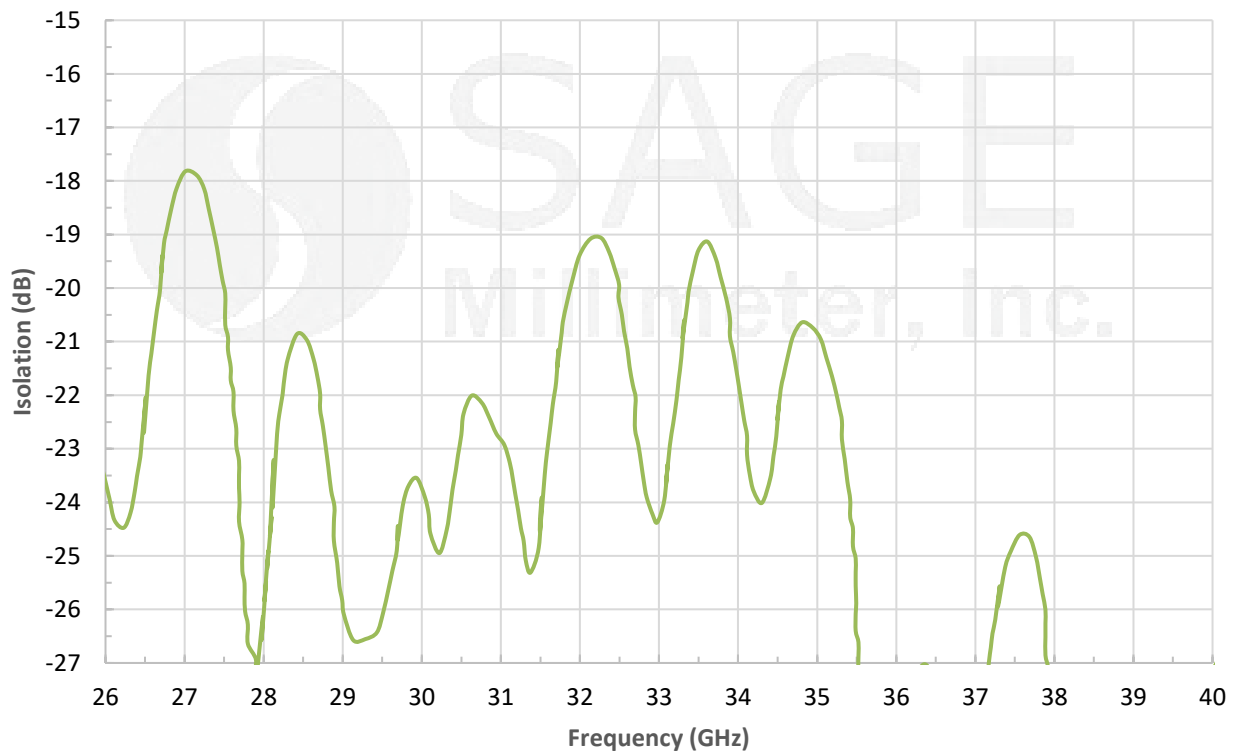



8-Way Coaxial Power Splitter, 26.5 to 40 GHz

Typical Phase Unbalance vs. Frequency

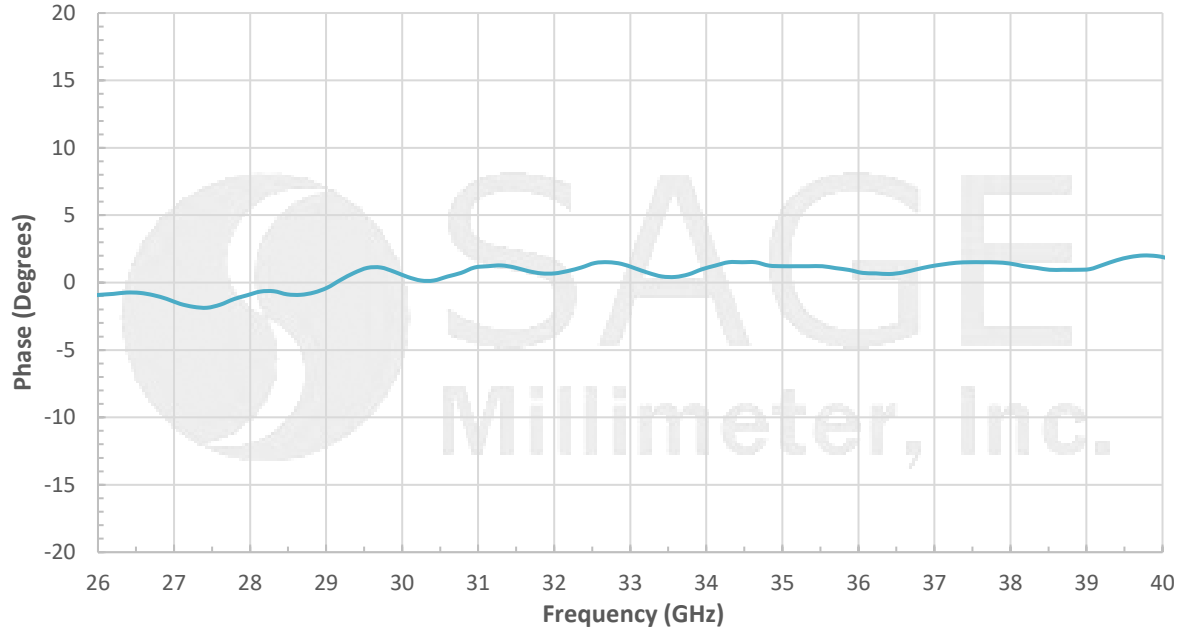

Mechanical Outline: (Unless otherwise specified, all dimensions are in inches [millimeters])

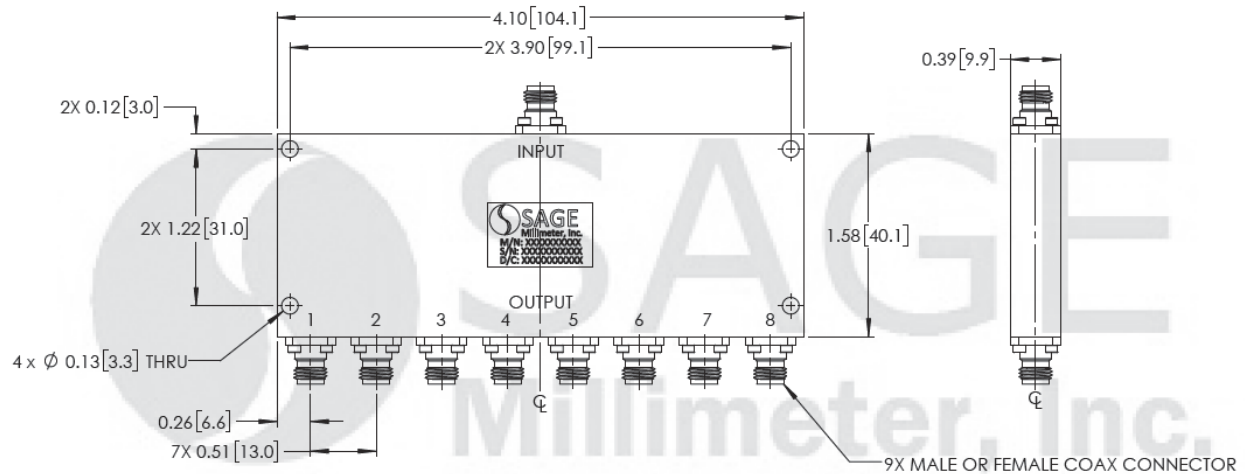

Note:

- All data presented is collected from a sample lot. Actual data may vary unit to unit, slightly.
- All testing was performed under +25 °C case temperature.
- SAGE Millimeter, Inc. reserves the right to change the information presented without notice.

Caution:

- Exceeding absolute maximum ratings of the switch will damage the device.
- Proper torque, 8.0 ± 0.15 inch-pounds (0.90 ± 0.02 Nm), should be applied. **SAGE Millimeter torque wrench, model SCH-08008-S1, is highly recommended.**

www.sagemillimeter.com | 3043 Kashiwa Street, Torrance, CA 90505
 Phone: 424-757-0168 | Fax: 424-757-0188 | Email: sales@sagemillimeter.com