



U-Band Waveguide to 2.4 mm Connector Adapter, End Launch

Description:

Models **SWC-192F-E1** and **SWC-192M-E1** are end launch (180°) U-Band waveguide to coax adapters that cover the frequency range of 40 to 50 GHz. The adapters are designed and manufactured for instrumentation grade quality but offered at a commercial grade price, allowing for an efficient transition between the rectangular waveguide and 2.4 mm coax connector. The right angle (90°) versions are offered under model numbers SWC-192F-R1 and SWC-192M-R1.



Features:

- Broad Band Coverage
- Lower Insertion Loss and Return Loss
- Instrumentation Grade
- DC Short Circuit

Applications:

- Test Lab
- Instrumentations
- Sub-assemblies

Electrical Specifications:

Parameter	Minimum	Typical	Maximum
Frequency Range*	40 GHz		50 GHz
Insertion Loss		0.3 dB	
Return Loss		18 dB	
Power Handling			40 W (CW)
Specification Temperature		+25 °C	
Operating Temperature	-40 °C		+85 °C

*Actual bandwidth may be wider.

Mechanical Specifications:

Item	Parameter
Waveguide	WR-19 with UG-383/U-M Flange
Coaxial	2.4 mm Female for Model Number: SWC-192F-E1
Coaxial	2.4 mm Male for Model Number: SWC-192M-E1
Housing Material	Aluminum
Finish	Gold Plated
Weight	0.4 Oz
Outline	WC-UE





U-Band Waveguide to 2.4 mm Connector Adapter, End Launch

Typical Return Loss vs. Frequency (Back to Back)

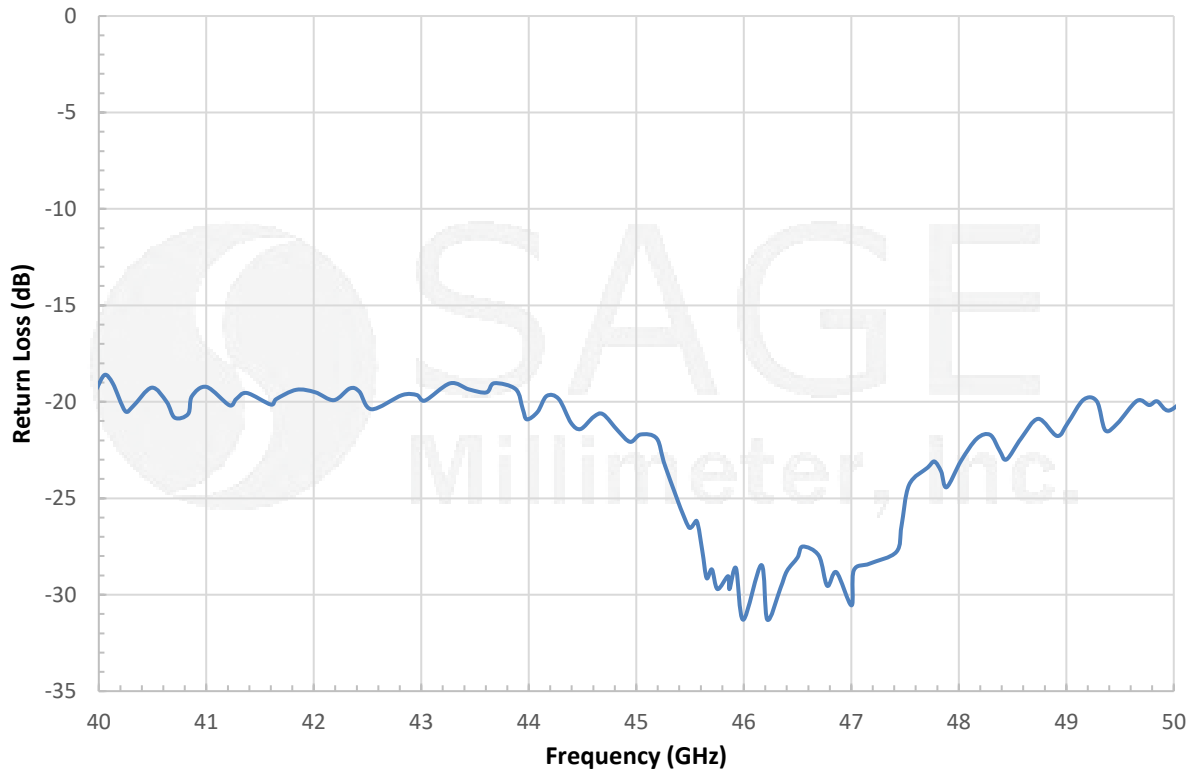

Mechanical Outline: (Unless otherwise specified, all dimensions are in inches [millimeters])

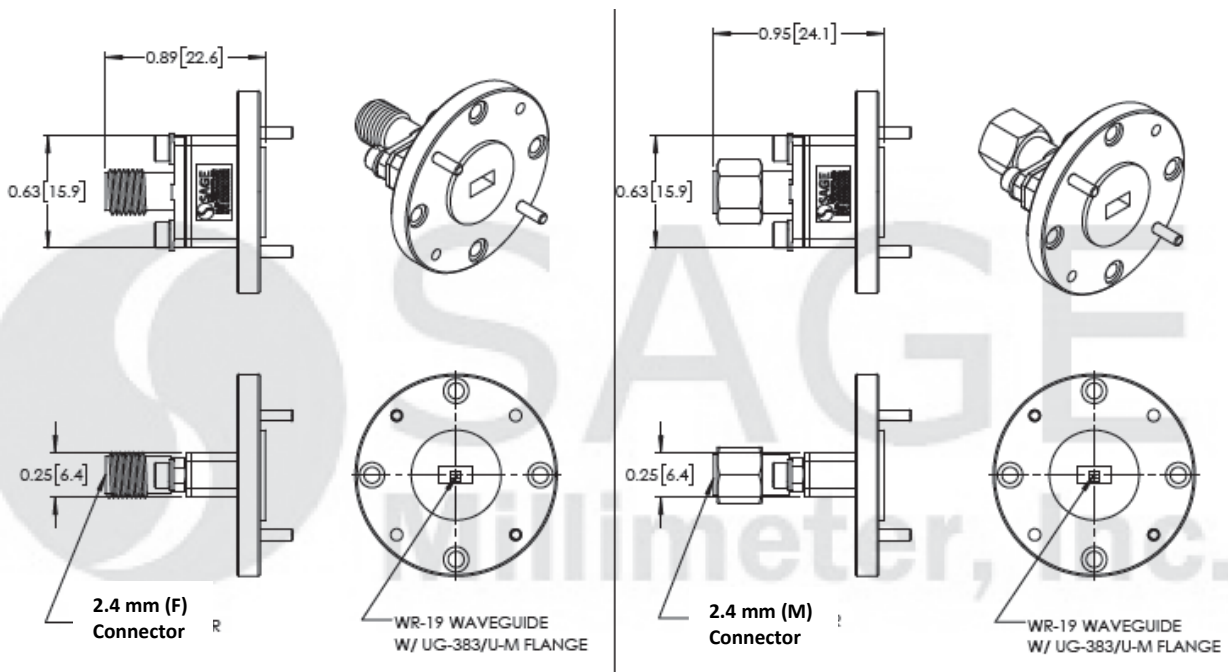



U-Band Waveguide to 2.4 mm Connector Adapter, End Launch

Note:

- All data presented is collected from a sample lot. Actual data may vary unit to unit, slightly.
- All testing was performed under +25°C case temperature.
- SAGE Millimeter, Inc. reserves the right to change the information presented without notice.
- Other mechanical configurations are available under different model numbers.

Caution:

- Any foreign objects in the waveguide will cause performance degradation and may damage the adapter.
- Proper torque, 8.0 ± 0.15 inch-pounds (0.90 ± 0.02 Nm), should be applied. **SAGE Millimeter torque wrench, model SCH-08008-U3, is highly recommended.**

