



## 1.85 mm (F) to 1.85 mm (F) Coaxial Adapter, Bulkhead

### Description:

**Model SCT-VFVF-U8-B** is a 1.85 mm female to 1.85 mm female coaxial adapter with a bulkhead that covers the frequency range of DC to 67 GHz. This coaxial adapter offers efficient transitioning between the coaxial connectors with a high return loss and typical insertion loss of 0.5 dB. The impedance of the adapter is 50 ohms. Other configurations are available under different model numbers.



### Features:

- Instrumentation Grade
- High Return Loss
- Low Insertion Loss

### Applications:

- Test Lab
- Sub-assemblies

### Electrical Specifications:

Parameter	Minimum	Typical	Maximum
Frequency	DC		67 GHz
Insertion Loss		0.5 dB	
Return Loss		17 dB	
Impedance		50 Ω	
Specification Temperature		+25 °C	
Operating Temperature	-40 °C		+85 °C

### Mechanical Specifications:

Item	Specification
Connector 1 Type	1.85 mm Female
Connector 2 Type	1.85 mm Female
Body Material	Stainless Steel
Body Finish	Passivated
Contact Material	Beryllium Copper
Insulator Material	PEI
Adapter Body Style	Bulkhead
Weight	0.2 Oz
Outline	CT-VFVF-B-SR1





## 1.85 mm (F) to 1.85 mm (F) Coaxial Adapter, Bulkhead

### Typical Performance vs. Frequency

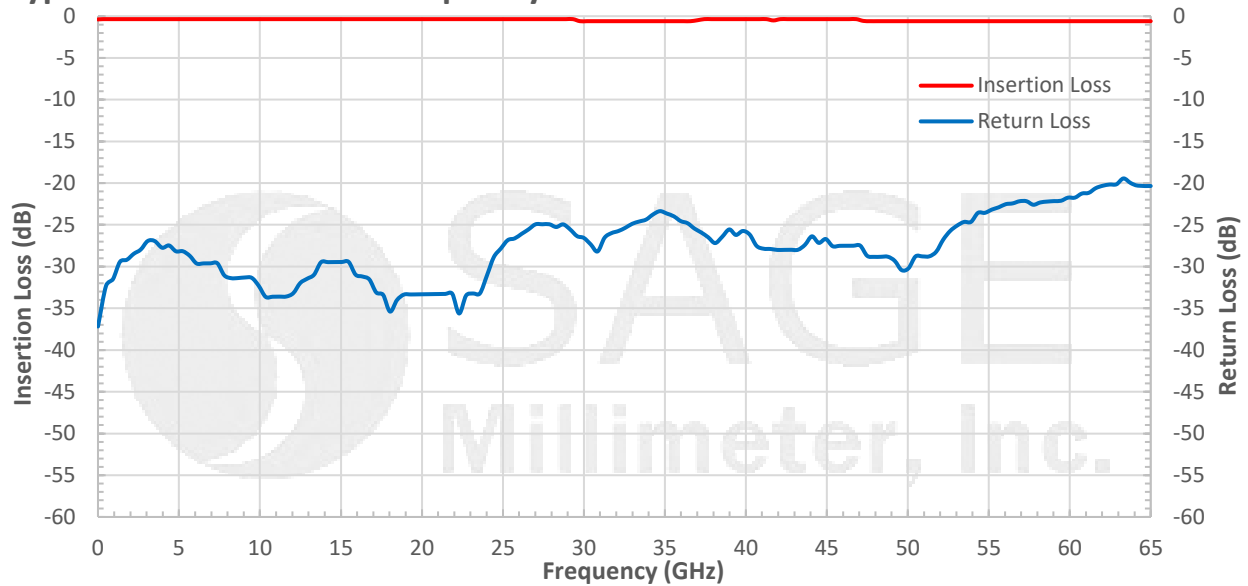

### Mechanical Outline: (Unless otherwise specified, all dimensions are in inches [millimeters])

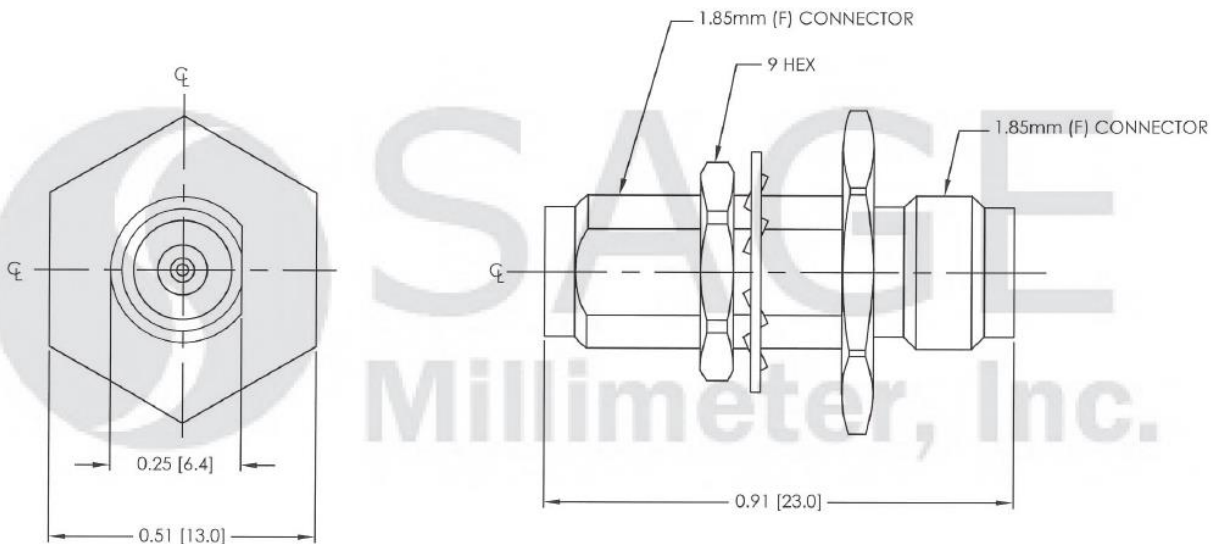

#### Note:

- All data presented is collected from a sample lot. Actual data may vary unit to unit.
- All testing was performed under +25°C case temperature.
- SAGE Millimeter, Inc. reserves the right to change the information presented without notice.

#### Caution:

- Proper torque, 8.0 ± 0.15 inch-pounds (0.90 ± 0.02 Nm), should be applied. **SAGE Millimeter torque wrench, model SCH-08008-U3, is highly recommended.**



www.sagemillimeter.com | 3043 Kashiwa Street, Torrance, CA 90505  
 Phone: 424-757-0168 | Fax: 424-757-0188 | Email: sales@sagemillimeter.com