



Q-Band Waveguide to 1.85mm Connector Adapter, Right Angle

Description:

Models **SWC-22VF-R1** and **SWC-22VM-R1** are right angle (90°) Q-Band waveguide to coax adapters that cover the frequency range of 33 to 50 GHz. They are designed and manufactured for instrumentation grade quality but offered at a commercial grade price, allowing for an efficient transition between the rectangular waveguide and 1.85 mm (V) coax connector. The end launch (180°) versions are offered under model numbers SWC-22VF-E1 and SWC-22VM-E1.



Features:

- Broad Band Coverage
- Lower Insertion Loss and VSWR
- Instrumentation Grade
- DC Open Circuit

Applications:

- Test Lab
- Instrumentations
- Sub-assemblies

Electrical Specifications:

Parameter	Minimum	Typical	Maximum
Frequency Range	33 GHz		50 GHz
Insertion Loss		0.3 dB	
Return Loss		18 dB	
Power Handling			30 W (CW)
Specification Temperature		+25°C	
Operating Temperature	-40°C		+85°C

Mechanical Specifications:

Item	Parameter
Waveguide	WR-22 with UG383/U Flange
Coaxial	1.85 mm (V) Female for Model Number: SWC-22VF-R1
Coaxial	1.85 mm (V) Male for Model Number: SWC-22VMF-R1
Size	1.00" (L) x 1.13" (D)
Housing Material	Aluminum
Finish	Gold Plated
Weight	0.4 Oz
Outline	WC-QR



Q-Band Waveguide to 1.85mm Connector Adapter, Right Angle

Typical Insertion Loss and Return Loss vs. Frequency (Back to Back)

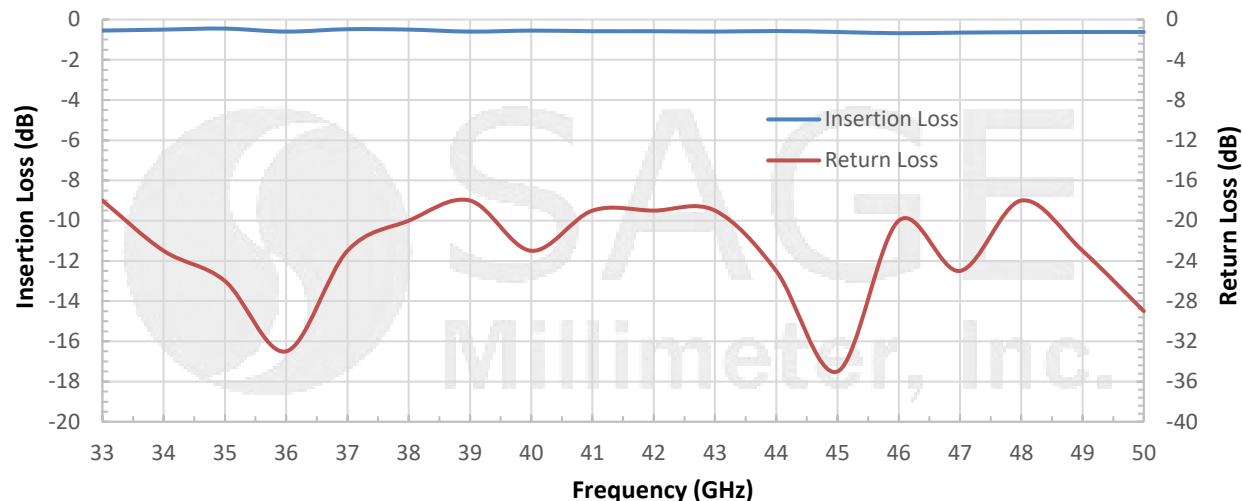

Mechanical Outline: (Unless otherwise specified, all dimensions are in inches)

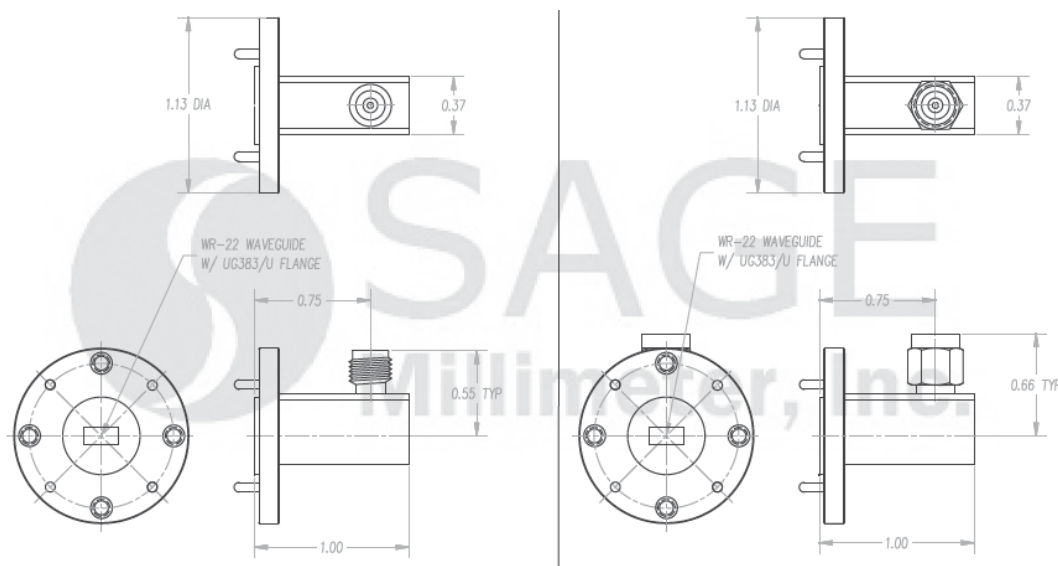

Note:

- All data are presented using a limited sample lot, actual data may vary unit to unit.
- All testing was performed under 25°C case temperature.
- SAGE Millimeter, Inc. reserves the right to change the information presented without notice.

Caution:

- Any foreign objects in the waveguide will cause performance degradation and may damage the adapter.
- Proper torque, 8.0 ± 0.15 inch-pounds (0.90 ± 0.02 Nm), should be applied. **SAGE Millimeter torque wrench, model SCH-08008-U3, is highly recommended.**



www.sagemillimeter.com | 3043 Kashiwa Street, Torrance, CA 90505
 Phone: 424-757-0168 | Fax: 424-757-0188 | Email: sales@sagemillimeter.com