



2.4 mm (M) to 2.4 mm (M) Coaxial Adapter

Description:

Model SCT-2M2M-UB is a 2.4 mm male to 2.4 mm male coaxial adapter that covers the frequency range of DC to 50 GHz. This coaxial adapter offers efficient transitioning between the coaxial connectors with a high return loss and typical insertion loss of 0.3 dB. The impedance of the adapter is 50 Ohms. Other configurations are available under different model numbers.



Features:

- Instrumentation Grade
- High Return Loss
- Low Insertion Loss

Applications:

- Test Lab
- Sub-assemblies

Electrical Specifications:

Parameter	Minimum	Typical	Maximum
Frequency	DC		50 GHz
Insertion Loss		0.3 dB	
Return Loss		21 dB	
Impedance		50 Ω	
Specification Temperature		+25 °C	
Operating Temperature	-40 °C		+85 °C

Mechanical Specifications:

Item	Specification
Connector 1 Type	2.4 mm Male
Connector 2 Type	2.4 mm Male
Body Material	Stainless Steel
Body Finish	Passivated
Contact Material	Beryllium Copper
Insulator Material	PEI
Weight	0.09 Oz (2.5 Grams)
Length	0.67"
Outline	CT-2M2M-LN1



2.4 mm (M) to 2.4 mm (M) Coaxial Adapter

Typical Performance vs. Frequency

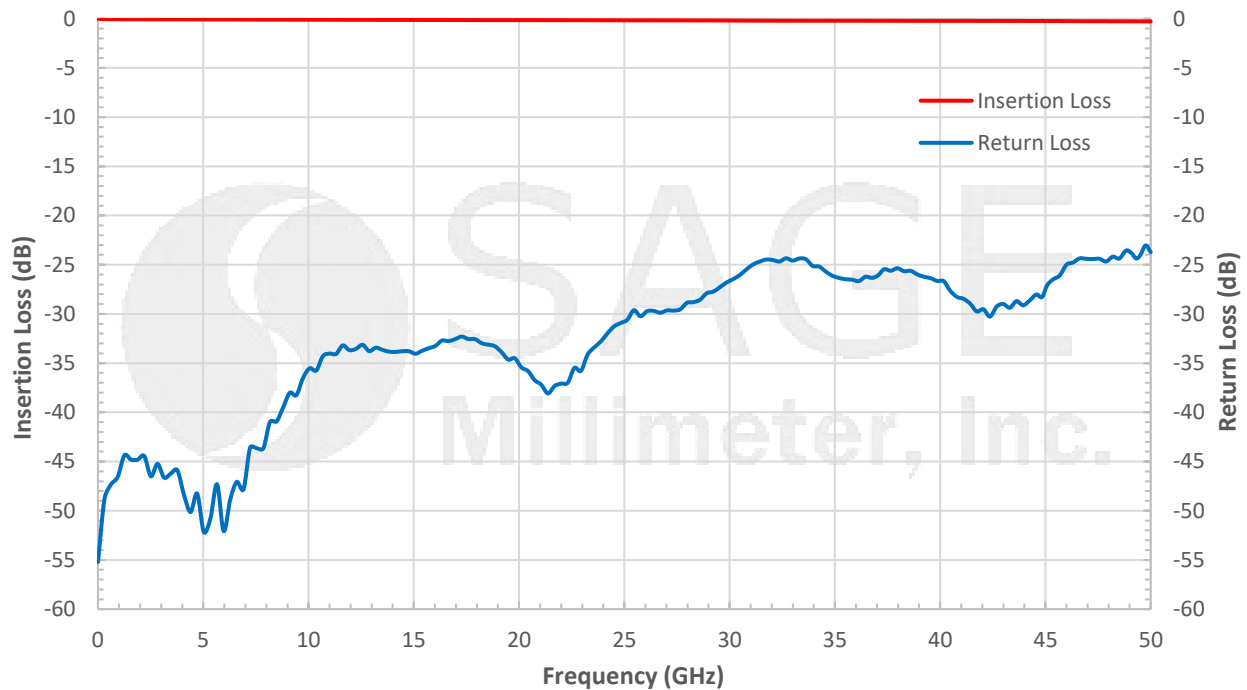

Mechanical Outline: (Unless otherwise specified, all dimensions are in inches [millimeters])

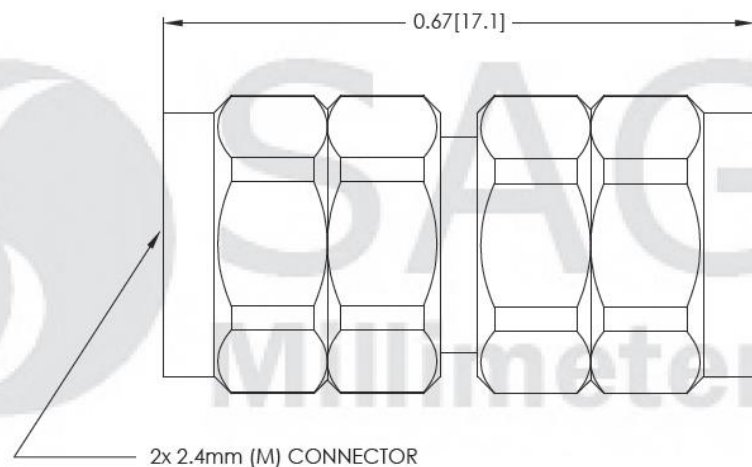

Note:

- All data presented is collected from a sample lot. Actual data may vary unit to unit, slightly.
- All testing was performed under +25 °C case temperature.
- SAGE Millimeter, Inc. reserves the right to change the information presented without notice.

Caution:

- Proper torque, 8.0 ± 0.15 inch-pounds (0.90 ± 0.02 Nm), should be applied. **SAGE Millimeter torque wrench, model SCH-08008-U3, is highly recommended.**



www.sagemillimeter.com | 3043 Kashiwa Street, Torrance, CA 90505
 Phone: 424-757-0168 | Fax: 424-757-0188 | Email: sales@sagemillimeter.com