



Universal Heatsink, 15-Watt Power Dissipation Capacity, Uni-Guide™ Compatible

Description:

Model SUA-15-S1 is a universal heatsink, which is designed and fabricated for SAGE Millimeter’s active device applications with up to 15-watt power dissipation. The heatsink consists of the main heatsink body, a DC fan and a heat spreader. The heat spreader is also known as adapter, which is used to bridge the mounting gap between the heat sink main body and the to-be-heat-sunk devices, such as power amplifier, frequency active multiplier, oscillator, transmitter and transceiver due to various mounting hole locations. The heat spreader offers various mounting patterns to accommodate more than 15 product models. This heatsink is not only designed for SAGE Millimeter’s standard products and Uni-Guide™ featured products, but also for many industrial standard microwave and millimeter wave products offered by other manufacturers. Other heatsinks with different power dissipation capacities are offered under different model numbers.



Features:

- High Power Dissipation Efficiency
- DC Powered Cooling Fan
- Heat Spreader for Various Mounting Patterns
- Easy Mounting and Dis-mounting

Applications:

- Single Function Components
- Sub-assemblies
- Lab Use

Electrical Specifications:

Parameter	Specification
Fan Power	+12 V _{dc}
Fan Power Designations	Red Lead (Positive); Black Lead (GND); Yellow Lead (N/A or Tach)
DC Connector	Molex 5051-03
Fan Detachability	Yes

Mechanical Specifications:

Item	Specification
Mounting Screw	2-56 x 3/16" Long, 4 Pieces
Material	Aluminum
Finishing	Clear Chem Film
Weight	2.0 Oz
Dimensions	1.57" x 1.57" x 1.33"
Outline	UA-15-1



Universal Heatsink, 15-Watt Power Dissipation Capacity, Uni-Guide™ Compatible

Mechanical Outline: (Unless otherwise specified, all dimensions are in inches [millimeters])

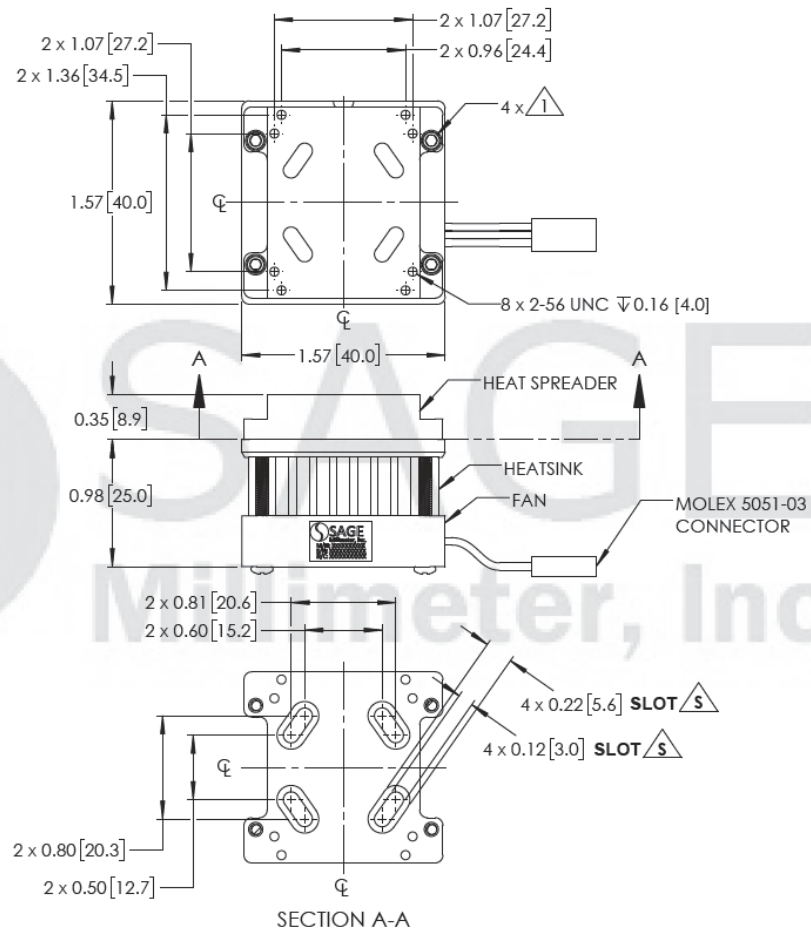

Mounting Instructions:

- Remove the heat spreader from the heatsink by unscrewing the four provided 2-56x3/16" long mounting screws.
- Mount the heat spreader onto the to-be-heat-sunk device by inserting 4-40 screws from the slotted surface to form the sub-assembly. Apply heat compound material between the two surfaces for better heatsink efficiency.
- Remount the sub-assembly onto the heatsink main body. Apply heat compound material if desired.

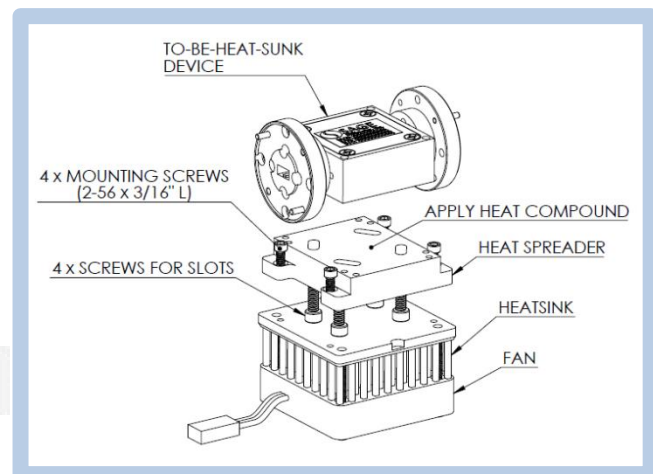

Note:

- SAGE Millimeter, Inc. reserves the right to change the information presented without notice.



www.sagemillimeter.com | 3043 Kashiwa Street, Torrance, CA 90505
 Phone: 424-757-0168 | Fax: 424-757-0188 | Email: sales@sagemillimeter.com