

INA21x-Q1 汽车级电压输出、低侧或高侧测量、双向、零漂移系列电流分流监控器

1 特性

- 符合 AEC-Q100 标准，具有：
 - 温度等级 1: -40°C 至 $+125^{\circ}\text{C}$ 环境温度范围
 - 器件人体放电模式 (HBM) 静电放电 (ESD) 分类等级 2
 - 器件 CDM ESD 分类等级 C6
- 宽共模范围: -0.3V 至 26V
- 失调电压: $\pm 100\mu\text{V}$ (最大值)
(支持 10mV 满量程分流压降)
- 精度:
 - $\pm 1\%$ 增益误差 (不同温度下的最大值, 版本 A 和 B)
 - $\pm 0.5\%$ 增益误差 (版本 C)
 - $0.5\mu\text{V}/^{\circ}\text{C}$ 偏移漂移 (最大值)
 - $10\text{ppm}/^{\circ}\text{C}$ 增益漂移 (最大值)
- 增益选择:
 - INA210-Q1: 200 V/V
 - INA211-Q1: 500 V/V
 - INA212-Q1: 1000 V/V
 - INA213-Q1: 50 V/V
 - INA214-Q1: 100 V/V
 - INA215-Q1: 75 V/V
- 静态电流: $100\mu\text{A}$ (最大值)
- SC70 封装

2 应用

- 车身控制模块
- 阀控制
- 电机控制
- 电子稳定控制
- 无线充电发送器

3 说明

INA21x-Q1 系列器件是电压输出、电流分流监控器 (也称为电流感应放大器), 可在独立于电源电压的 -0.3V 至 26V 范围内的共模电压中感应分流器上的压降。提供了五种固定增益: 50V/V 、 75V/V 、 100V/V 、 200V/V 、 500V/V 和 1000V/V 。该系列器件通常用于过流检测、电压反馈控制环路或用作功率监控器。零漂移架构的低偏移使得该器件能够在分流器上的最大压降低至 10mV (满量程) 的情况下进行电流感应。

这些器件由 2.7V 至 26V 的单个电源供电, 消耗的最大电源电流为 $100\mu\text{A}$ 。这些器件具有 -40°C 至 $+125^{\circ}\text{C}$ 的工作温度范围, 并且采用 6 引脚 SC70 封装。

器件信息(1)

器件型号	封装	封装尺寸 (标称值)
INA210-Q1	SC70 (6)	2.00mm × 1.25mm
INA211-Q1	SC70 (6)	2.00mm × 1.25mm
INA212-Q1	SC70 (6)	2.00mm × 1.25mm
INA213-Q1	SC70 (6)	2.00mm × 1.25mm
INA214-Q1	SC70 (6)	2.00mm × 1.25mm
INA215-Q1	SC70 (6)	2.00mm × 1.25mm

(1) 要了解所有可用封装, 请参见产品说明书末尾的可订购产品附录。

简化电路原理图

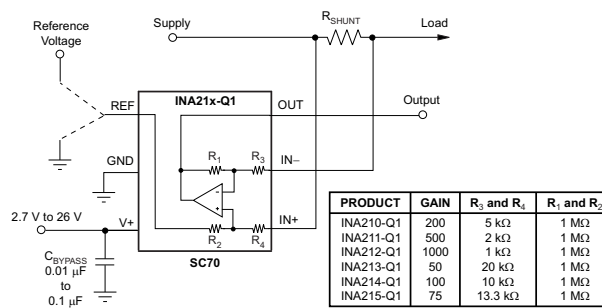

$$V_{\text{OUT}} = (I_{\text{LOAD}} \times R_{\text{SHUNT}}) \text{Gain} + V_{\text{REF}}$$

Copyright © 2017, Texas Instruments Incorporated



目录

1 特性	1	7.4 Device Functional Modes	14
2 应用	1	8 Application and Implementation	20
3 说明	1	8.1 Application Information	20
4 修订历史记录	2	8.2 Typical Applications	20
5 Pin Configuration and Functions	4	9 Power Supply Recommendations	23
6 Specifications	5	10 Layout	23
6.1 Absolute Maximum Ratings	5	10.1 Layout Guidelines	23
6.2 ESD Ratings	5	10.2 Layout Example	23
6.3 Recommended Operating Conditions	5	11 器件和文档支持	24
6.4 Thermal Information	5	11.1 文档支持	24
6.5 Electrical Characteristics	6	11.2 相关链接	24
6.6 Typical Characteristics	8	11.3 社区资源	24
7 Detailed Description	12	11.4 商标	24
7.1 Overview	12	11.5 静电放电警告	24
7.2 Functional Block Diagram	12	11.6 Glossary	24
7.3 Feature Description	13	12 机械、封装和可订购信息	24

4 修订历史记录

注：之前版本的页码可能与当前版本有所不同。

Changes from Revision G (May 2016) to Revision H	Page
• Deleted <i>Device Options</i> table	4
• Added V_{DIF} to analog input parameter in <i>Absolute Maximum Ratings</i> table	5
• Added V_S table note in <i>Absolute Maximum Ratings</i> table	5
• Changed formatting of <i>Thermal Information</i> table note	5
• Deleted first table note in <i>Electrical Characteristics</i> table	6
• Added version C to input test conditions in <i>Electrical Characteristics</i> table	6
• Added version C test conditions to gain error parameter in <i>Electrical Characteristics</i> table	6
• 已更改 图 7, 图 10, 图 15, 图 17, 图 18, 图 19, 图 20, 图 21 and 图 22 to match commercial data sheet	8
• 已添加 test conditions to 图 8, 图 9, 图 10, and 图 11 and 图 12 from INA21x commercial data sheet	8
• 已更改 x-axis unit in 图 17 from "ms" to "μs"	9

Changes from Revision F (April 2016) to Revision G	Page
• INA210-Q1、INA211-Q1 和 INA215-Q1 已投入生产	1
• 在器件信息表中删除了第二个脚注	1

Changes from Revision E (December 2014) to Revision F	Page
• 更改了第一个特性项目	1
• 更改了增益选择特性项目：添加了 INA210-Q1、INA211-Q1 和 INA215-Q1 子项目，从 INA213-Q1 中删除了 A	1
• 更改了“说明”部分的第一段	1
• 更改了器件信息表：添加了 INA210-Q1、INA211-Q1、INA215-Q1 行，从 INA213A-Q1 中删除了 A，将封装项从 SOT 更改成了 SC70	1
• 更改了简化原理图：更改了数字表	1
• Deleted footnote 1 from <i>Pin Functions</i> table	4
• Changed <i>Absolute Maximum Ratings</i> table: changed operating temperature from -55°C to 150°C to -40°C to 125°C	5

• Changed Changed <i>ESD Ratings</i> table: changed title, made CDM values all one row because corner pins and all other pins tested the same, added separation of specs for versions A and B, and moved the storage temperature to <i>Absolute Maximum Ratings</i> table; added version B devices	5
• Changed <i>Electrical Characteristics</i> table: changed conditions and changed all INA213A-Q1 to INA213-Q1	6
• Changed Input, V_{CM} parameter in <i>Electrical Characteristics</i> table	6
• Changed Input, $CMRR$ and V_{OS} parameters in <i>Electrical Characteristics</i> table	6
• Changed Output, <i>Gain</i> parameter in <i>Electrical Characteristics</i> table	6
• Deleted test conditions from Output, <i>Nonlinearity error</i> parameter in <i>Electrical Characteristics</i> table	6
• Changed Frequency Response, <i>BW</i> parameter in <i>Electrical Characteristics</i> table	7
• Changed conditions of <i>Typical Characteristics</i> section	8
• Changed Figure 7	8
• Changed Figure 15	9
• Changed first sentence of <i>Overview</i> section	12
• Changed first sentence of <i>Basic Connections</i> section	13
• Changed last paragraph of <i>Selecting R_S</i> section	13
• Changed Table 1 and Table 2	15
• Changed Figure 25	16
• Changed <i>Improving Transient Robustness</i> section: changed first paragraph, added caution and last paragraph.....	19

Changes from Revision D (October 2013) to Revision E
Page

• Added <i>Handling Rating</i> table, <i>Feature Description</i> section, <i>Device Functional Modes, Application and Implementation</i> section, <i>Power Supply Recommendations</i> section, <i>Layout</i> section, <i>Device and Documentation Support</i> section, and <i>Mechanical, Packaging, and Orderable Information</i> section	5
• Deleted θ_{JA} thermal resistance parameter from <i>Electrical Characteristics</i>	7

Changes from Revision C (August 2013) to Revision D
Page

• 已更改 通篇将 INA213-Q1 器件更改成了 INA213A-Q1 器件.....	1
• Deleted T_A , Operating Temperature from <i>ABSOLUTE MAXIMUM RATINGS</i> table	5

Changes from Revision B (June 2010) to Revision C
Page

• 通篇将器件名称更改成了 -Q1	1
• 在“特性”中 添加了“INA212-Q1: 1000V/V”。	1
• 更改了该列表, 使其全部特定于汽车	1
• 在“说明”中添加了“INA212-Q1 提供 1000V/V 的固定 增益”。	1
• 在图像中添加了 INA212-Q1。	1
• Deleted <i>Ordering Information</i> table	5
• Changed HBM to 2000 V, removed MM.	5
• Changed T_A to -40 to 125°C.....	5
• Added INA212-Q1 values to $CMRR$ V_{OS} and <i>Gain</i> in <i>Electrical Characteristics</i> table	6
• Changed <i>Bandwidth</i> parameter in the <i>ELECTRICAL CHARACTERISTICS</i> to differentiate between devices.....	7
• 已更改 <i>GAIN vs FREQUENCY</i> graph to show difference between devices	8
• Added INA212-Q1 device name in <i>App Information</i>	13
• Added INA212-Q1 to image.	16

5 Pin Configuration and Functions

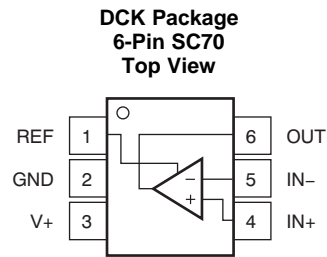

Pin Functions

PIN		I/O	DESCRIPTION
NAME	NO.		
GND	2	—	Ground
IN-	5	I	Connect to load side of shunt resistor.
IN+	4	I	Connect to supply side of shunt resistor
OUT	6	O	Output voltage
REF	1	I	Reference voltage, 0 V to V+
V+	3	—	Power supply, 2.7 V to 26 V

6 Specifications

6.1 Absolute Maximum Ratings

over operating free-air temperature range (unless otherwise noted)⁽¹⁾

		MIN	MAX	UNIT
Supply voltage, V_S ⁽²⁾			26	V
Analog inputs, V_{IN+} , V_{IN-} ⁽³⁾	Differential : $V_{DIF} = (V_{IN+}) - (V_{IN-})$	-26	26	V
	Common-mode (Version A)	GND - 0.3	26	
	Common-mode (Versions B and C)	GND - 0.1	26	V
REF input		GND - 0.3	$(V_S) + 0.3$	V
Output ⁽⁴⁾		GND - 0.3	$(V_S) + 0.3$	V
Input current into any pin ⁽⁴⁾			5	mA
Operating temperature		-40	125	°C
Junction temperature			150	°C
Storage temperature, T_{stg}		-65	150	°C

- (1) Stresses beyond those listed under *Absolute Maximum Ratings* may cause permanent damage to the device. These are stress ratings only, which do not imply functional operation of the device at these or any other conditions beyond those indicated under *Recommended Operating Conditions*. Exposure to absolute-maximum-rated conditions for extended periods may affect device reliability.
- (2) V_S refers to the voltage at the V+ pin.
- (3) V_{IN+} and V_{IN-} are the voltages at the IN+ and IN- pins, respectively.
- (4) Input voltage at any pin can exceed the voltage shown if the current at that pin is limited to 5 mA.

6.2 ESD Ratings

			VALUE	UNIT
INA21x-Q1 (VERSION A)				
$V_{(ESD)}$	Electrostatic discharge	Human body model (HBM), per AEC Q100-002 ⁽¹⁾	±2000	V
		Charged device model (CDM), per AEC Q100-011	±1000	
INA21x-Q1 (VERSIONS B AND C)				
$V_{(ESD)}$	Electrostatic discharge	Human body model (HBM), per AEC Q100-002 ⁽¹⁾	±3500	V
		Charged device model (CDM), per AEC Q100-011	±1000	

- (1) AEC Q100-002 indicates HBM stressing is done in accordance with the ANSI/ESDA/JEDEC JS-001 specification.

6.3 Recommended Operating Conditions

over operating free-air temperature range (unless otherwise noted)

		MIN	NOM	MAX	UNIT
V_{CM}	Common-mode input voltage		12		V
V_S	Supply voltage	2.7		26	V
T_J	Junction temperature	-40		125	°C

6.4 Thermal Information

THERMAL METRIC ⁽¹⁾		INA21x-Q1	UNIT
		DCK (SC70)	
		6 PINS	
$R_{\theta JA}$	Junction-to-ambient thermal resistance	227.3	°C/W
$R_{\theta JC(top)}$	Junction-to-case (top) thermal resistance	79.5	°C/W
$R_{\theta JB}$	Junction-to-board thermal resistance	72.1	°C/W
Ψ_{JT}	Junction-to-top characterization parameter	3.6	°C/W
Ψ_{JB}	Junction-to-board characterization parameter	70.4	°C/W

- (1) For more information about traditional and new thermal metrics, see the [Semiconductor and IC Package Thermal Metrics](#) application report.

6.5 Electrical Characteristics

 at $T_A = 25^\circ\text{C}$, $V_{\text{SENSE}} = V_{\text{IN+}} - V_{\text{IN-}}$.

 INA210-Q1, INA213-Q1, INA214-Q1, and INA215-Q1: $V_S = 5\text{ V}$, $V_{\text{IN+}} = 12\text{ V}$, and $V_{\text{REF}} = V_S / 2$, (unless otherwise noted)

 INA211-Q1 and INA212-Q1: $V_S = 12\text{ V}$, $V_{\text{IN+}} = 12\text{ V}$, and $V_{\text{REF}} = V_S / 2$, (unless otherwise noted)

PARAMETER	TEST CONDITIONS	MIN	TYP	MAX	UNIT	
INPUT						
V_{CM} Common-mode input	Version A $T_A = -40^\circ\text{C}$ to 125°C	-0.3		26	V	
	Versions B and C $T_A = -40^\circ\text{C}$ to 125°C	-0.1		26		
CMRR Common-mode rejection ratio	$V_{\text{IN+}} = 0\text{ V}$ to 26 V $V_{\text{SENSE}} = 0\text{ mV}$ $T_A = -40^\circ\text{C}$ to 125°C	INA210-Q1 INA211-Q1 INA212-Q1 INA214-Q1 INA215-Q1	105	140	dB	
		INA213-Q1	100	120		
V_{OS} Offset voltage, RTI ⁽¹⁾	$V_{\text{SENSE}} = 0\text{ mV}$ $T_A = 25^\circ\text{C}$	INA210-Q1 INA211-Q1 INA212-Q1		± 0.55	± 35	μV
		INA213-Q1		± 5	± 100	
		INA214-Q1 INA215-Q1		± 1	± 60	
dV_{OS}/dT Offset voltage vs temperature ⁽²⁾	$T_A = -40^\circ\text{C}$ to 125°C		0.1	0.5	$\mu\text{V}/^\circ\text{C}$	
PSR Offset voltage vs power supply	$V_S = 2.7\text{ V}$ to 18 V $V_{\text{IN+}} = 18\text{ V}$ $V_{\text{SENSE}} = 0\text{ mV}$ $T_A = 25^\circ\text{C}$		± 0.1	± 10	$\mu\text{V}/\text{V}$	
I_B Input bias current	$V_{\text{SENSE}} = 0\text{ mV}$ $T_A = 25^\circ\text{C}$	15	28	35	μA	
I_{OS} Input offset current	$V_{\text{SENSE}} = 0\text{ mV}$ $T_A = 25^\circ\text{C}$		± 0.02		μA	
OUTPUT						
Gain	INA210-Q1		200		V/V	
	INA211-Q1		500			
	INA212-Q1		1000			
	INA213-Q1		50			
	INA214-Q1		100			
	INA215-Q1		75			
Gain error	$V_{\text{SENSE}} = -5\text{ mV}$ to 5 mV (Versions A and B) $T_A = -40^\circ\text{C}$ to 125°C		$\pm 0.02\%$	$\pm 1\%$		
	$V_{\text{SENSE}} = -5\text{ mV}$ to 5 mV (Version C) $T_A = -40^\circ\text{C}$ to 125°C		$\pm 0.02\%$	$\pm 0.5\%$		
Gain error vs temperature ⁽²⁾	$T_A = -40^\circ\text{C}$ to 125°C		3	10	ppm/ $^\circ\text{C}$	
Nonlinearity error	$T_A = 25^\circ\text{C}$		$\pm 0.01\%$			
Maximum capacitive load	No sustained oscillation $T_A = 25^\circ\text{C}$		1		nF	
VOLTAGE OUTPUT						
Output voltage swing to V_+ power-supply rail ⁽³⁾	$R_L = 10\text{ k}\Omega$ to GND $T_A = -40^\circ\text{C}$ to 125°C		$(V_+) - 0.05$	$(V_+) - 0.2$	V	
Output voltage swing to GND	$T_A = -40^\circ\text{C}$ to 125°C		$(V_{\text{GND}}) + 0.005$	$(V_{\text{GND}}) + 0.05$	V	

(1) RTI = referred to input.

(2) Not production tested.

 (3) See [Figure 10](#) in *Typical Characteristics*.

Electrical Characteristics (continued)

 at $T_A = 25^\circ\text{C}$, $V_{\text{SENSE}} = V_{\text{IN}+} - V_{\text{IN}-}$

 INA210-Q1, INA213-Q1, INA214-Q1, and INA215-Q1: $V_S = 5\text{ V}$, $V_{\text{IN}+} = 12\text{ V}$, and $V_{\text{REF}} = V_S / 2$, (unless otherwise noted)

 INA211-Q1 and INA212-Q1: $V_S = 12\text{ V}$, $V_{\text{IN}+} = 12\text{ V}$, and $V_{\text{REF}} = V_S / 2$, (unless otherwise noted)

PARAMETER		TEST CONDITIONS		MIN	TYP	MAX	UNIT
FREQUENCY RESPONSE							
BW	Bandwidth	$C_{\text{LOAD}} = 10\text{ pF}$	INA210-Q1	$T_A = 25^\circ\text{C}$		14	kHz
			INA211-Q1			7	
			INA212-Q1			4	
			INA213-Q1			80	
			INA214-Q1			30	
			INA215-Q1			40	
SR	Slew rate	$T_A = 25^\circ\text{C}$			0.4		V/ μs
NOISE, RTI							
	Voltage noise density	RTI ⁽¹⁾ $T_A = 25^\circ\text{C}$			25		nV/ $\sqrt{\text{Hz}}$
POWER SUPPLY							
I_Q	Quiescent current	$V_{\text{SENSE}} = 0\text{ mV}$	$T_A = 25^\circ\text{C}$		65	100	μA
			$T_A = -40^\circ\text{C}$ to 125°C			115	

6.6 Typical Characteristics

at $T_A = 25^\circ\text{C}$, $V_S = 5\text{ V}$, $V_{IN+} = 12\text{ V}$, and $V_{REF} = V_S / 2$, (unless otherwise noted)



图 1. Input Offset Voltage Production Distribution



图 2. Offset Voltage vs Temperature

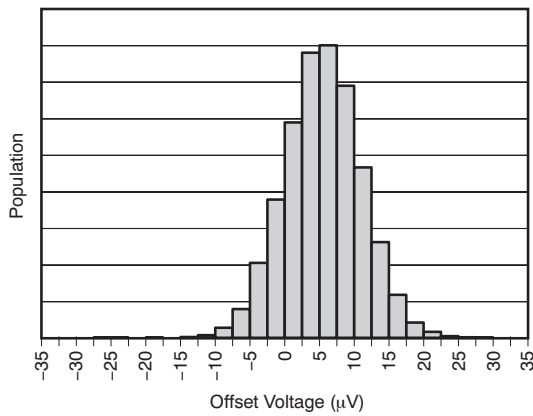

图 3. Common-Mode Rejection Production Distribution

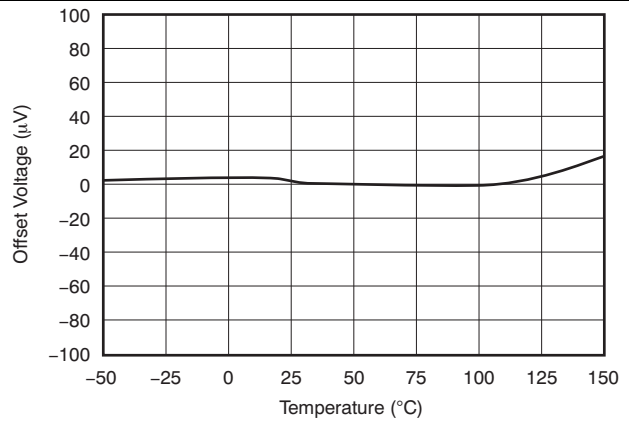

图 4. Common-Mode Rejection Ratio vs Temperature

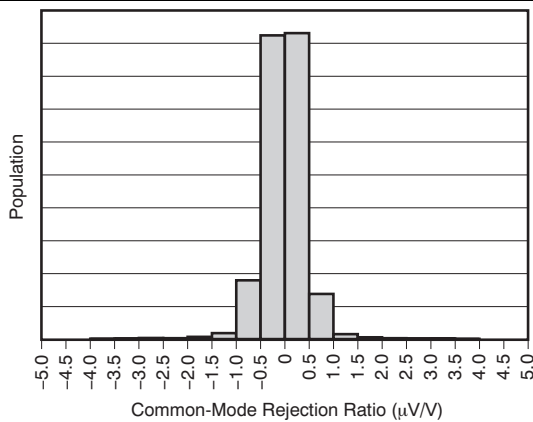

图 5. Gain Error Production Distribution

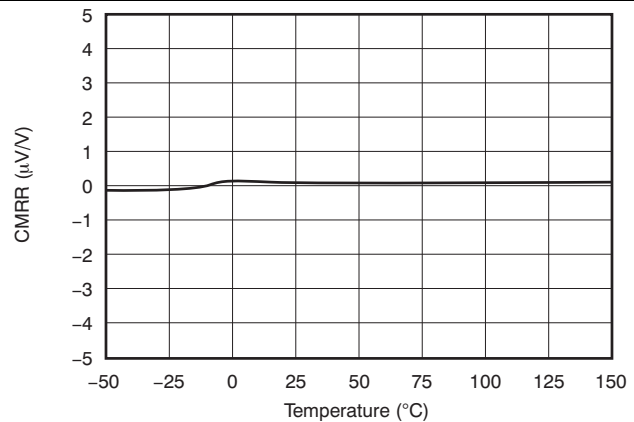

图 6. Gain Error vs Temperature

Typical Characteristics (接下页)

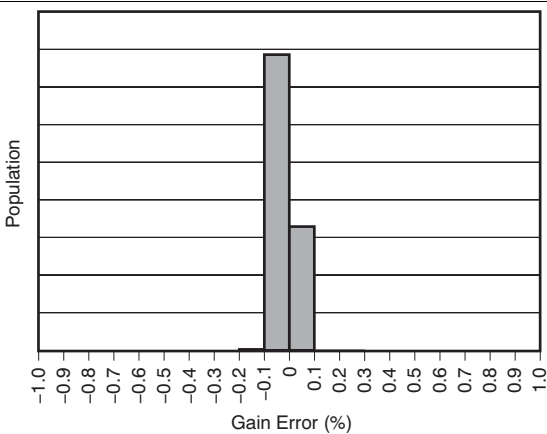
at $T_A = 25^\circ\text{C}$, $V_S = 5\text{ V}$, $V_{IN+} = 12\text{ V}$, and $V_{REF} = V_S / 2$, (unless otherwise noted)

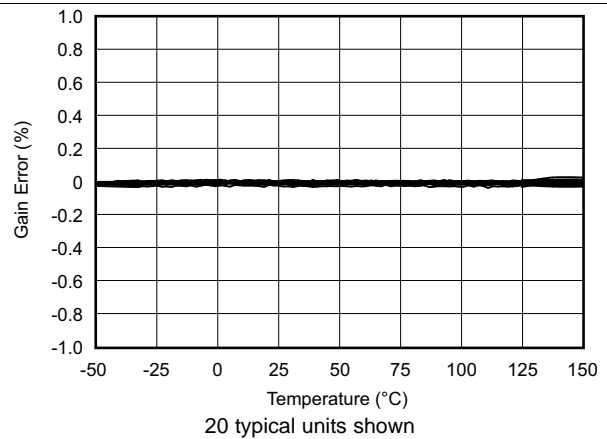

图 7. Gain vs Frequency



图 8. Power-Supply Rejection Ratio vs Frequency

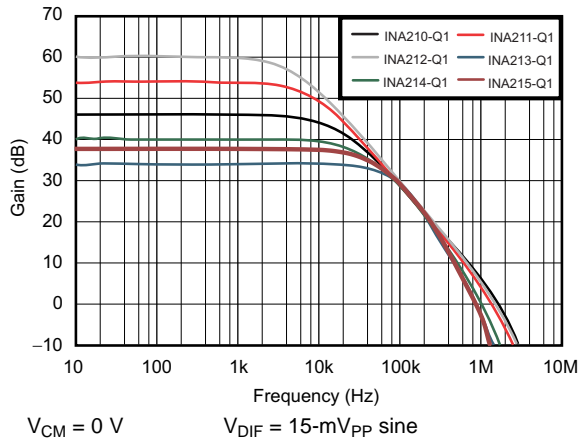

图 9. Common-Mode Rejection Ratio vs Frequency

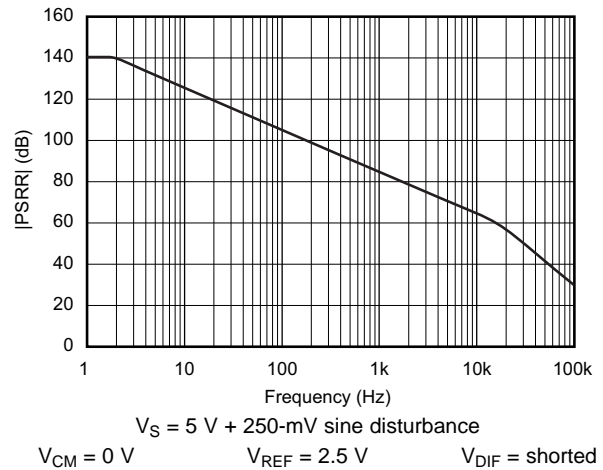

图 10. Output Voltage Swing vs Output Current

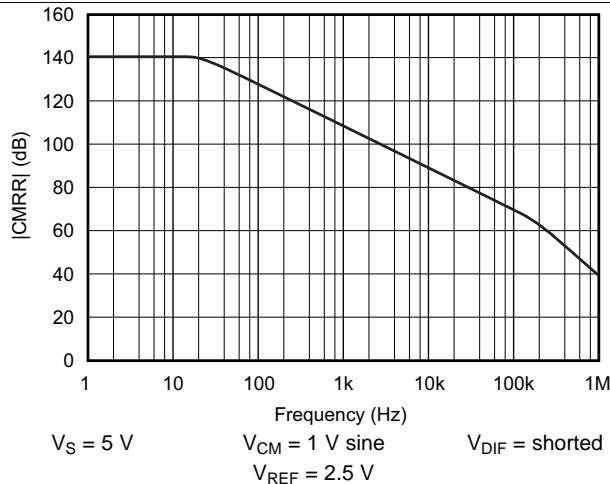

图 11. Input Bias Current vs Common-Mode Voltage With Supply Voltage = 5 V

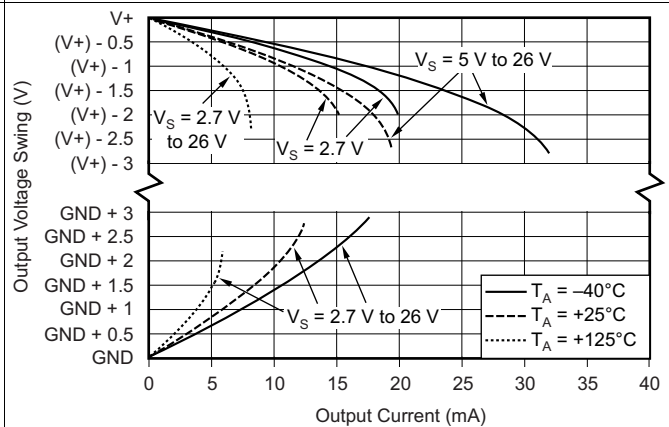

图 12. Input Bias Current vs Common-Mode Voltage With Supply Voltage = 0 V (Shutdown)

Typical Characteristics (接下页)

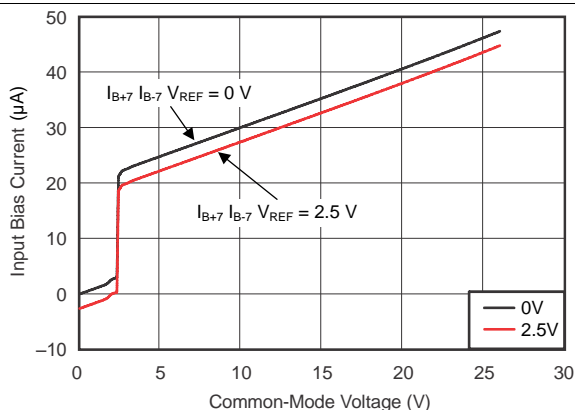
at $T_A = 25^\circ\text{C}$, $V_S = 5\text{ V}$, $V_{IN+} = 12\text{ V}$, and $V_{REF} = V_S / 2$, (unless otherwise noted)

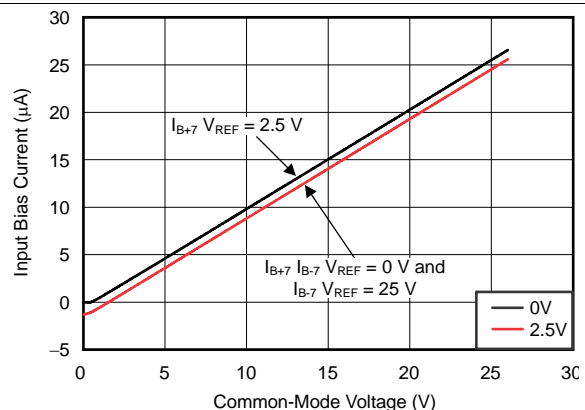
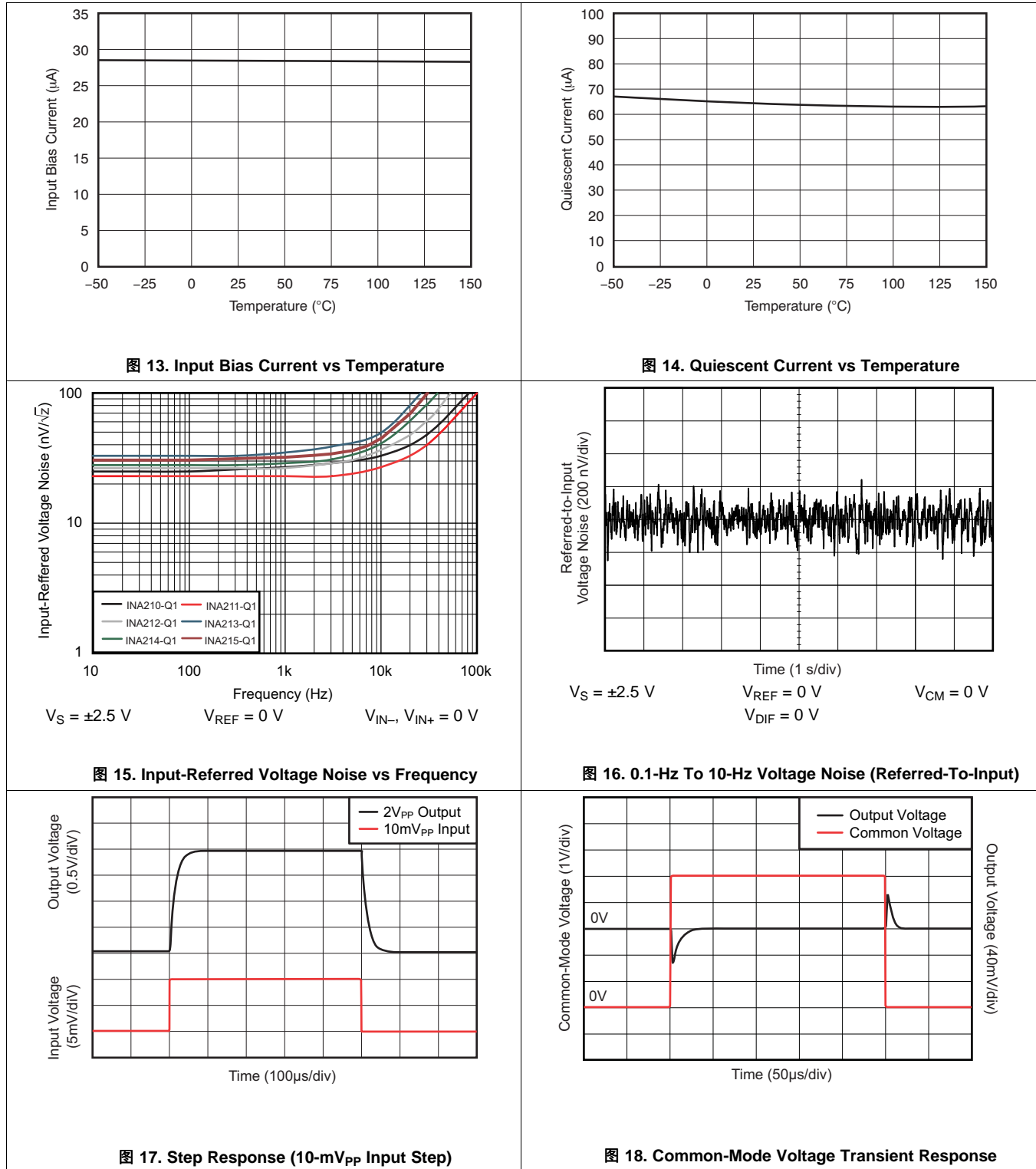

Typical Characteristics (接下一页)

at $T_A = 25^\circ\text{C}$, $V_S = 5\text{ V}$, $V_{IN+} = 12\text{ V}$, and $V_{REF} = V_S / 2$, (unless otherwise noted)

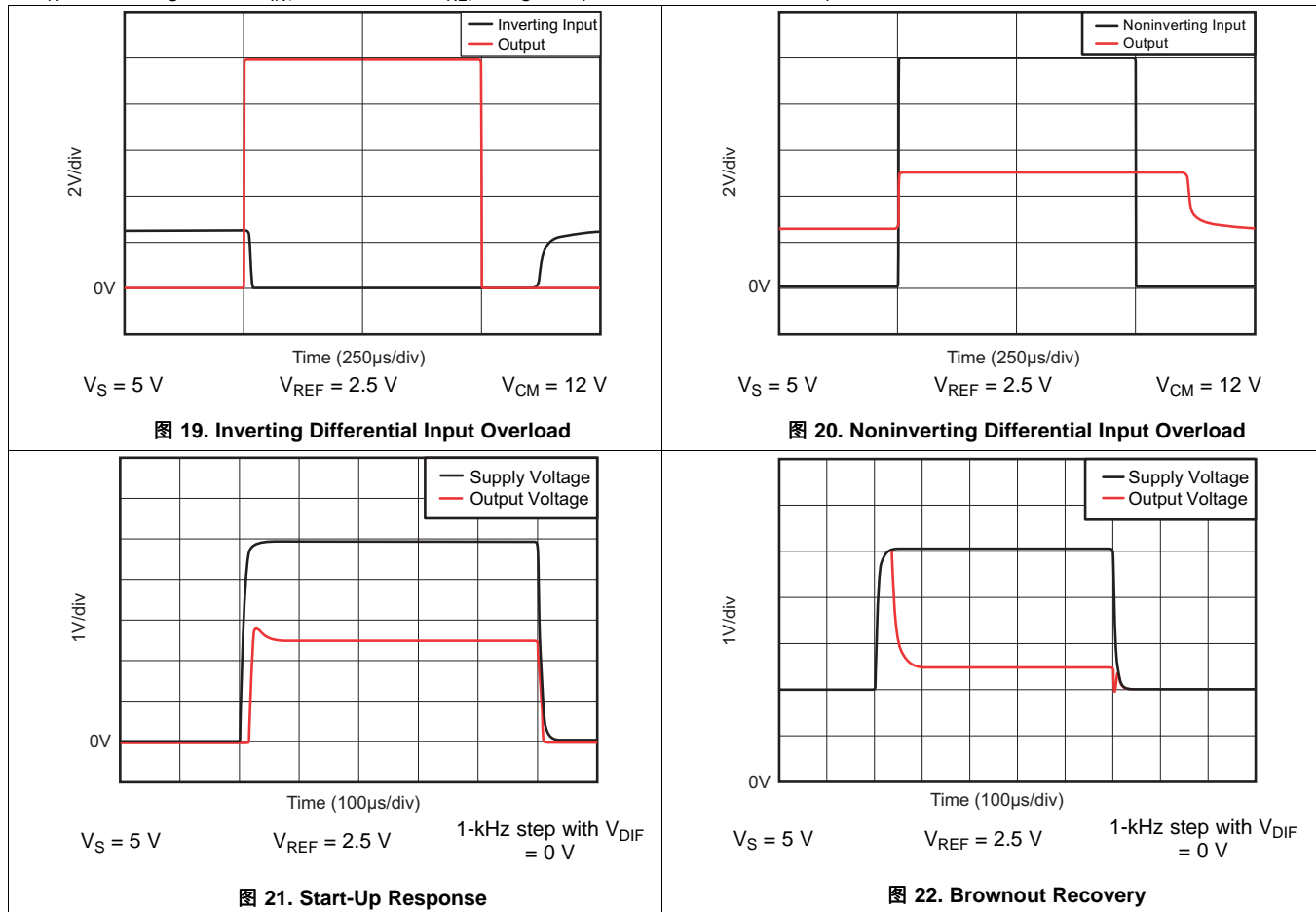

7 Detailed Description

7.1 Overview

The INA210-Q1 to INA215-Q1 are 26-V, common-mode, zero-drift topology, current-sensing amplifiers that can be used in both low-side and high-side configurations. These specially-designed, current-sensing amplifiers are able to accurately measure voltages developed across current-sensing resistors on common-mode voltages that far exceed the supply voltage powering the device. Current can be measured on input voltage rails as high as 26 V and the device can be powered from supply voltages as low as 2.7 V.

The zero-drift topology enables high-precision measurements with maximum input offset voltages as low as 35 μV with a maximum temperature contribution of 0.5 $\mu\text{V}/^\circ\text{C}$ over the full temperature range of -40°C to 125°C .

7.2 Functional Block Diagram

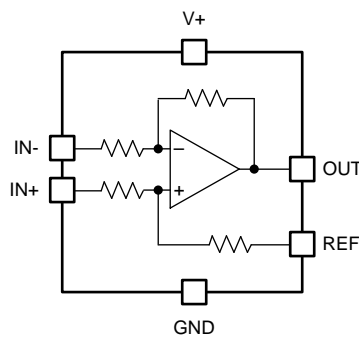

Copyright © 2017, Texas Instruments Incorporated

7.3 Feature Description

7.3.1 Basic Connections

Figure 23 shows the basic connections of the INA210-Q1 to INA215-Q1. Connect the input pins (IN+ and IN-) as closely as possible to the shunt resistor to minimize any resistance in series with the shunt resistor.

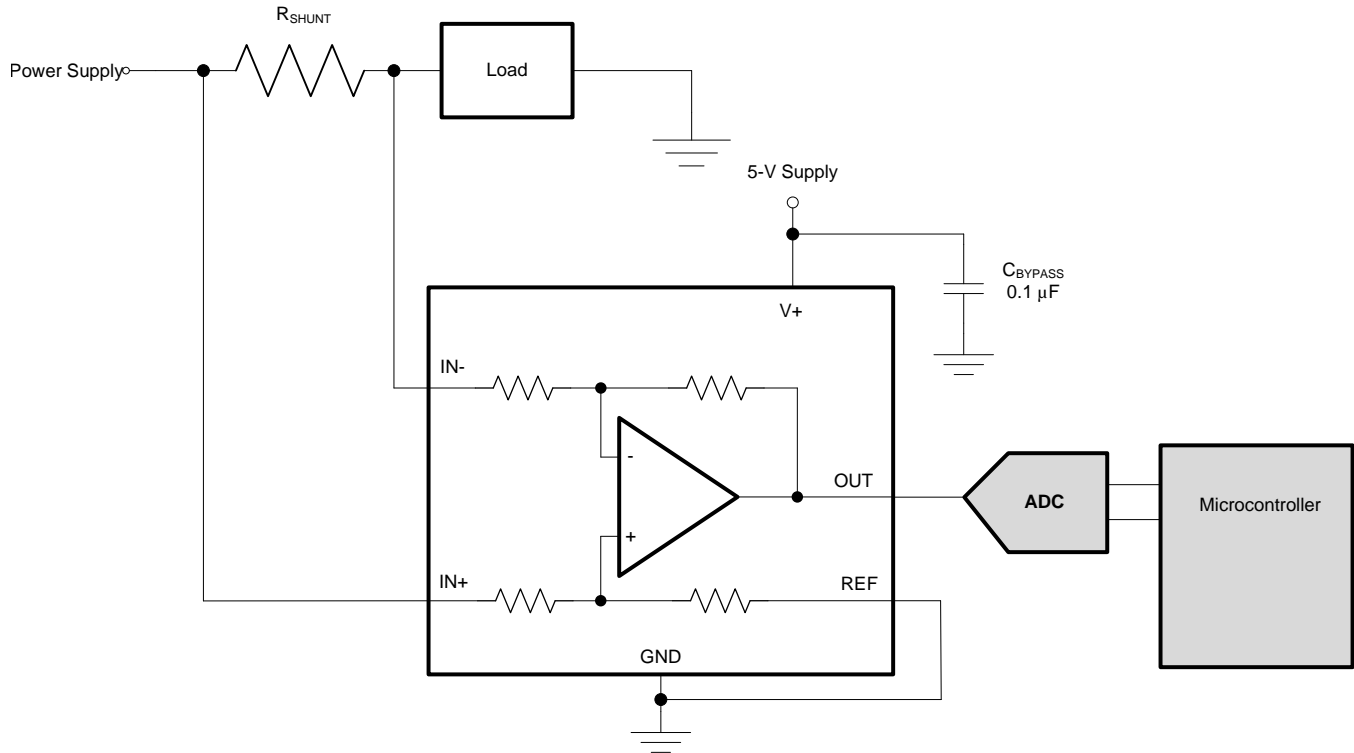

Copyright © 2017, Texas Instruments Incorporated

图 23. Typical Application

Power-supply bypass capacitors are required for stability. Applications with noisy or high-impedance power supplies can require additional decoupling capacitors to reject power-supply noise. Connect bypass capacitors close to the device pins.

7.3.2 Selecting R_S

The zero-drift offset performance of the INA21x-Q1 family of devices offers several benefits. In general, the primary advantage of the low offset characteristic enables lower full-scale drops across the shunt. For example, non-zero-drift current-shunt monitors typically require a full-scale range of 100 mV.

The INA21x-Q1 family of devices provides equivalent accuracy at a full-scale range on the order of 10 mV. This accuracy reduces shunt dissipation by an order of magnitude with many additional benefits.

Alternatively, some applications must measure current over a wide dynamic range and can take advantage of the low offset on the low end of the measurement. Most often, these applications can use the lower-gain INA213-Q1, INA214-Q1, or INA215-Q1 to accommodate larger shunt drops on the upper end of the scale. For instance, an INA213-Q1 device operating on a 3.3-V supply can easily support a full-scale shunt drop of 60 mV, with only 100 μ V of offset.

7.4 Device Functional Modes

7.4.1 Input Filtering

An obvious and straightforward location for filtering is at the output of the INA21x-Q1 family of devices. However, this location negates the advantage of the low output impedance of the internal buffer. The only other filtering option is at the input pins of the INA21x-Q1 family of devices. This location, however, requires consideration of the $\pm 30\%$ tolerance of the internal resistances. [图 24](#) shows a filter placed at the input pins.



图 24. Filter at Input Pins

The addition of external series resistance, however, creates an additional error in the measurement so the value of these series resistors must be kept to $10\ \Omega$ (or less, if possible) to reduce impact to accuracy. The internal bias network shown in [图 24](#) that is present at the input pins creates a mismatch in input bias currents when a differential voltage is applied between the input pins. If additional external series filter resistors are added to the circuit, the mismatch in bias currents results in a mismatch of voltage drops across the filter resistors. This mismatch creates a differential error voltage that subtracts from the voltage developed at the shunt resistor. This error results in a voltage at the device input pins that is different than the voltage developed across the shunt resistor. Without the additional series resistance, the mismatch in input bias currents has little effect on device operation. The amount of error these external filter resistors add to the measurement can be calculated using [公式 2](#) where the gain error factor is calculated using [公式 1](#).

The amount of variance in the differential voltage present at the device input relative to the voltage developed at the shunt resistor is based both on the external series resistance value as well as the internal input resistors, R_3 and R_4 (or R_{INT} as shown in [图 24](#)). The reduction of the shunt voltage reaching the device input pins appears as a gain error when comparing the output voltage relative to the voltage across the shunt resistor. A factor can be calculated to determine the amount of gain error that is introduced by the addition of external series resistance. Use [公式 1](#) to calculate the expected deviation from the shunt voltage to what is measured at the device input pins.

$$\text{Gain Error Factor} = \frac{(1250 \times R_{INT})}{(1250 \times R_S) + (1250 \times R_{INT}) + (R_S \times R_{INT})}$$

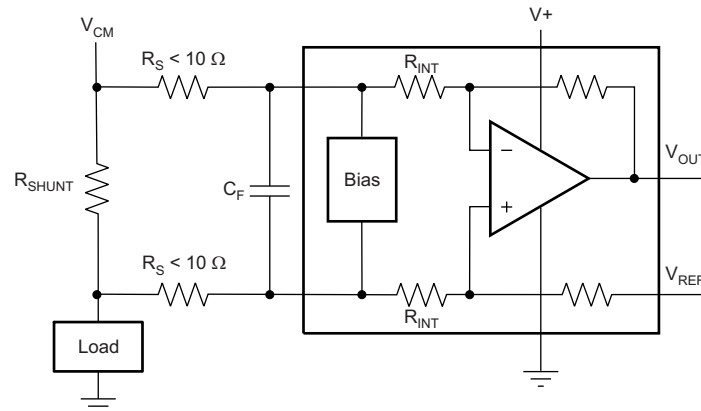
where:

- R_{INT} is the internal input resistor (R_3 and R_4), and
- R_S is the external series resistance.

(1)

Device Functional Modes (接下页)

With the adjustment factor from [公式 1](#) including the device internal input resistance, this factor varies with each gain version, as shown in [表 1](#). [表 2](#) lists each individual device gain-error factor.

表 1. Input Resistance

PRODUCT	GAIN	R _{INT} (kΩ)
INA210-Q1	200	5
INA211-Q1	500	2
INA212-Q1	1000	1
INA213-Q1	50	20
INA214-Q1	100	10
INA215-Q1	75	13.3

表 2. Device Gain Error Factor

PRODUCT	SIMPLIFIED GAIN ERROR FACTOR
INA210-Q1	$\frac{1000}{R_S + 1000}$
INA211-Q1	$\frac{10,000}{(13 \times R_S) + 10,000}$
INA212-Q1	$\frac{5000}{(9 \times R_S) + 5000}$
INA213-Q1	$\frac{20,000}{(17 \times R_S) + 20,000}$
INA214-Q1	$\frac{10,000}{(9 \times R_S) + 10,000}$
INA215-Q1	$\frac{8,000}{(7 \times R_S) + 8,000}$

Use [公式 2](#) to calculate the gain error that can be expected from the addition of the external series resistors.

$$\text{Gain Error (\%)} = 100 - (100 \times \text{Gain Error Factor}) \quad (2)$$

For example, using an INA212-Q1 device and the corresponding gain error equation from [表 2](#), a series resistance of 10 Ω results in a gain error factor of 0.982. The corresponding gain error is then calculated using [公式 2](#), resulting in a gain error of approximately 1.77% solely because of the external 10-Ω series resistors. Using an INA213-Q1 with the same 10-Ω series resistor results in a gain error factor of 0.991 and a gain error of 0.84% again solely because of these external resistors.

7.4.2 Shutting Down the INA21x-Q1 Series

While the INA21x-Q1 family of devices does not have a shutdown pin, the low-power consumption of the device allows the output of a logic gate or transistor switch to power the device. This gate or switch turns on and turns off the INA21x-Q1 power-supply quiescent current.

However, in current-shunt monitoring applications, the amount of current drained from the shunt circuit in shutdown conditions must be considered. Evaluating this current drain involves considering the simplified schematic of the INA21x-Q1 family of devices in shutdown mode shown in [图 25](#).

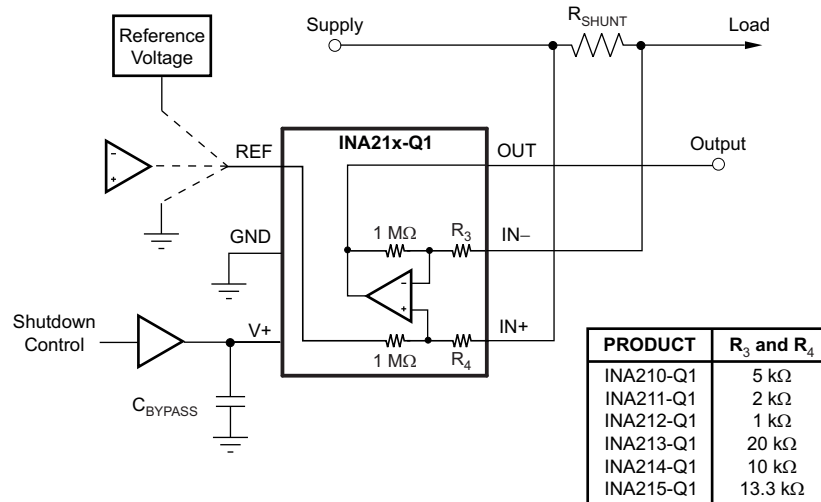

Copyright © 2017, Texas Instruments Incorporated

NOTE: 1-MΩ paths from shunt inputs to reference and INA21x-Q1 outputs.

图 25. Basic Circuit for Shutting Down INA21x-Q1 With a Grounded Reference

Slightly more than a 1-MΩ impedance (from the combination of 1-MΩ feedback and 5-kΩ input resistors) exists from each input of the INA21x-Q1 family of devices to the OUT pin and to the REF pin. The amount of current flowing through these pins depends on the respective ultimate connection. For example, if the REF pin is grounded, the calculation of the effect of the 1-MΩ impedance from the shunt to ground is straightforward. However, if the reference or operational amplifier (op amp) is powered when the INA21x-Q1 family of devices is shut down, the calculation is direct. Instead of assuming 1 MΩ to ground, however, assume 1 MΩ to the reference voltage. If the reference or op amp is also shut down, some knowledge of the reference or op amp output impedance under shutdown conditions is required. For instance, if the reference source behaves as an open circuit when not powered, little or no current flows through the 1-MΩ path.

Regarding the 1-MΩ path to the output pin, the output stage of a disabled INA21x-Q1 device does constitute a good path to ground; consequently, this current is directly proportional to a shunt common-mode voltage present across a 1-MΩ resistor.

注

When the device is powered up, an additional, nearly constant and well-matched 25-μA current flows in each of the inputs as long as the shunt common-mode voltage is 3 V or higher. Below 2-V common-mode, the only current effects are the result of the 1-MΩ resistors.

7.4.3 REF Input Impedance Effects

As with any difference amplifier, the INA21x-Q1 common-mode rejection ratio is affected by any impedance present at the REF input. This concern is not a problem when the REF pin is connected directly to most references or power supplies. When using resistive dividers from the power supply or a reference voltage, buffer the REF pin by an op amp.

In systems where the INA21x-Q1 output can be sensed differentially, such as by a differential input analog-to-digital converter (ADC) or by using two separate ADC inputs, the effects of external impedance on the REF input can be cancelled. [Figure 26](#) shows a method of taking the output from the INA21x-Q1 family of devices by using the REF pin as a reference.

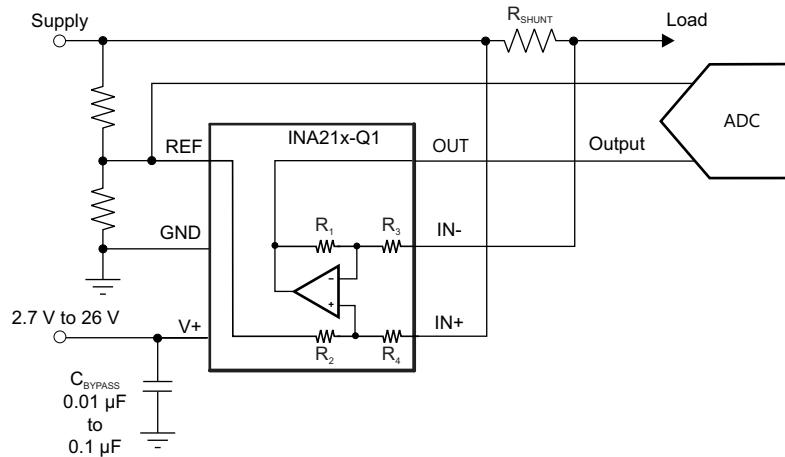

Copyright © 2017, Texas Instruments Incorporated

图 26. Sensing INA21x-Q1 to Cancel Effects of Impedance on the REF Input

7.4.4 Using the INA21x-Q1 with Common-Mode Transients Above 26 V

With a small amount of additional circuitry, the INA21x-Q1 family of devices can be used in circuits subject to transients higher than 26 V, such as automotive applications. Use only Zener diode or Zener-type transient absorbers (sometimes referred to as *transzorbs*)—any other type of transient absorber has an unacceptable time delay. Begin by adding a pair of resistors as a working impedance for the Zener diode, as shown in [Figure 27](#). Keeping these resistors as small as possible is preferable, typically around 10 Ω . Larger values can be used with an effect on gain that is discussed in the [Input Filtering](#) section. Because this circuit limits only short-term transients, many applications are satisfied with a 10- Ω resistor along with conventional Zener diodes of the lowest power rating that can be found. This combination uses the least amount of board space. These diodes can be found in packages as small as SOT-523 or SOD-523.

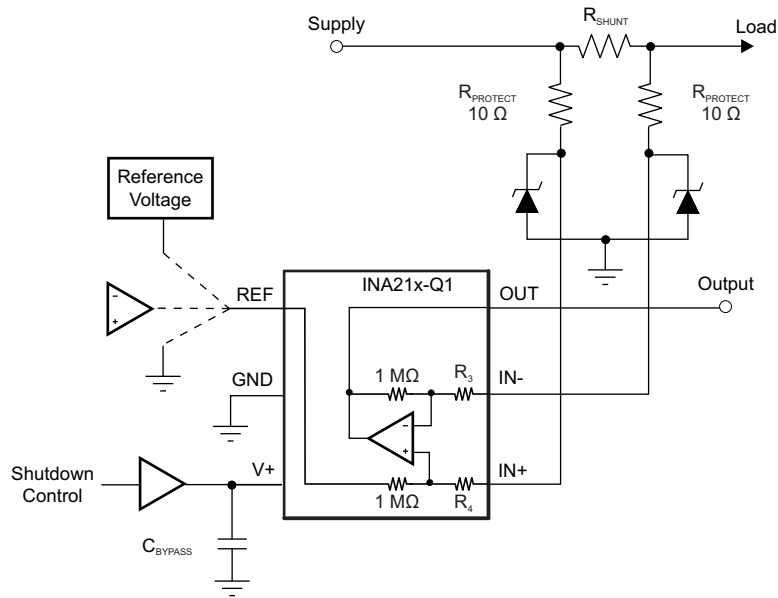

Copyright © 2017, Texas Instruments Incorporated

图 27. INA21x-Q1 Transient Protection Using Dual Zener Diodes

In the event that low-power Zener diodes do not have sufficient transient absorption capability and a higher power transzorb must be used, the most package-efficient solution then involves using a single transzorb and back-to-back diodes between the device inputs. The most space-efficient solutions are dual series-connected diodes in a single SOT-523 or SOD-523 package. 图 28 shows this method. In either of these examples, the total board area required by the INA21x-Q1 family of devices with all protective components is less than that of an SO-8 package, and only slightly greater than that of an MSOP-8 package.

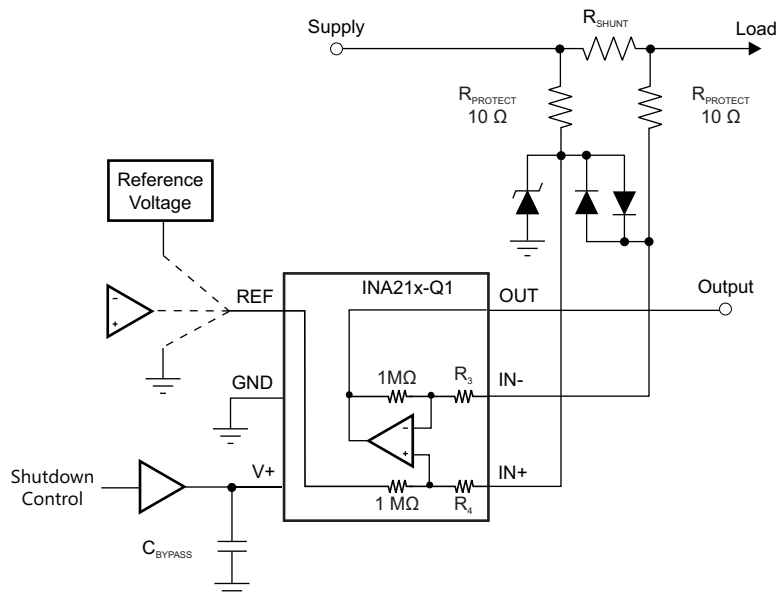

Copyright © 2017, Texas Instruments Incorporated

图 28. INA21x-Q1 Transient Protection Using a Single Transzorb and Input Clamps

7.4.5 Improving Transient Robustness

CAUTION

Applications involving large input transients with excessive dV/dt above 2 kV per microsecond present at the device input pins can cause damage to the internal ESD structures on version A devices.

The potential damage from large input transients is a result of the internal latching of the ESD structure to ground when this transient occurs at the input. With significant current available in most current-sensing applications, the large current flowing through the input transient-triggered, ground-shorted ESD structure quickly results in damage to the silicon. External filtering can be used to attenuate the transient signal prior to reaching the inputs to avoid the latching condition. Care must be taken to ensure that external series input resistance does not significantly impact gain error accuracy. For accuracy purposes, keep these resistances under 10 Ω if possible. Ferrite beads are recommended for this filter because of the inherently low-dc ohmic value. Ferrite beads with less than 10 Ω of resistance at dc and over 600 Ω of resistance at 100 MHz to 200 MHz are recommended. The recommended capacitor values for this filter are between 0.01 μF and 0.1 μF to ensure adequate attenuation in the high-frequency region. 图 29 illustrates this protection scheme.

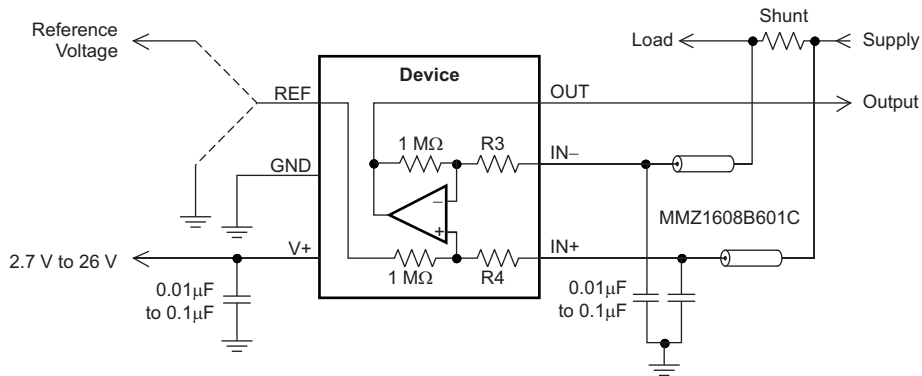

Copyright © 2017, Texas Instruments Incorporated

图 29. Transient Protection

To minimize the cost of adding these external components to protect the device in applications where large transient signals may be present, version B and C devices are now available with new ESD structures that are not susceptible to this latching condition. Version B and C devices are incapable of sustaining these damage-causing latched conditions so they do not have the same sensitivity to the transients that the version A devices have, thus making the version B and C devices a better fit for these applications.

8 Application and Implementation

注

Information in the following applications sections is not part of the TI component specification, and TI does not warrant its accuracy or completeness. TI's customers are responsible for determining suitability of components for their purposes. Customers should validate and test their design implementation to confirm system functionality.

8.1 Application Information

The INA21x-Q1 family of devices measure the voltage developed across a current-sensing resistor when current passes through the resistor. The ability to drive the reference pin to adjust the functionality of the output signal offers multiple configurations, as discussed throughout the [Typical Applications](#) section.

8.2 Typical Applications

8.2.1 Unidirectional Operation

Unidirectional operation allows the INA21x-Q1 family of devices to measure currents through a resistive shunt in one direction. The most frequent case of unidirectional operation sets the output at ground by connecting the REF pin to ground. In unidirectional applications where the highest possible accuracy is desirable at very low inputs, bias the REF pin to a convenient value above 50 mV to get the device output swing into the linear range for zero inputs.

A less frequent case of unipolar output biasing is to bias the output by connecting the REF pin to the supply. In this case, the quiescent output for zero input is at quiescent supply. This configuration only responds to negative currents (inverted voltage polarity at the device input).

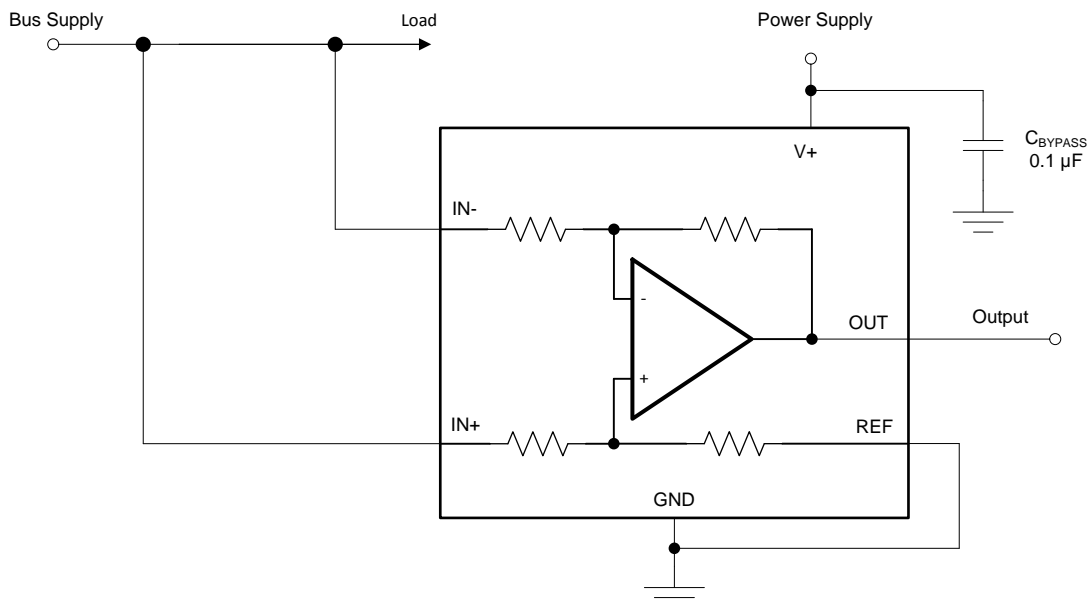

Copyright © 2017, Texas Instruments Incorporated

图 30. Unidirectional Application Schematic

8.2.1.1 Design Requirements

The device can be configured to monitor current flowing in one direction (unidirectional) or in both directions (bidirectional) depending on how the REF pin is configured. The most common case is unidirectional where the output is set to ground when no current is flowing by connecting the REF pin to ground, as shown in 图 30. When the input signal increases, the output voltage at the OUT pin increases.

Typical Applications (接下页)

8.2.1.2 Detailed Design Procedure

The linear range of the output stage is limited in how close the output voltage can approach ground under zero input conditions. In unidirectional applications where measuring very-low input currents is desirable, bias the REF pin to a convenient value above 50 mV to get the output into the linear range of the device. To limit common-mode rejection errors, TI recommends buffering the reference voltage connected to the REF pin.

A less frequently-used output biasing method is to connect the REF pin to the supply voltage, $V+$. This method results in the output voltage saturating at 200 mV below the supply voltage when no differential input signal is present. This method is similar to the output-saturated low condition with no input signal when the REF pin is connected to ground. The output voltage in this configuration only responds to negative currents that develop negative differential input voltage relative to the device $IN-$ pin. Under these conditions, when the differential input signal increases negatively, the output voltage moves downward from the saturated supply voltage. The voltage applied to the REF pin must not exceed the device supply voltage.

8.2.1.3 Application Curve

图 31 shows an example output response of a unidirectional configuration. With the REF pin connected directly to ground, the output voltage is biased to this zero output level. The output rises above the reference voltage for positive differential input signals but cannot fall below the reference voltage for negative differential input signals because of the grounded reference voltage.



图 31. Unidirectional Application Output Response

Typical Applications (接下页)

8.2.2 Bidirectional Operation

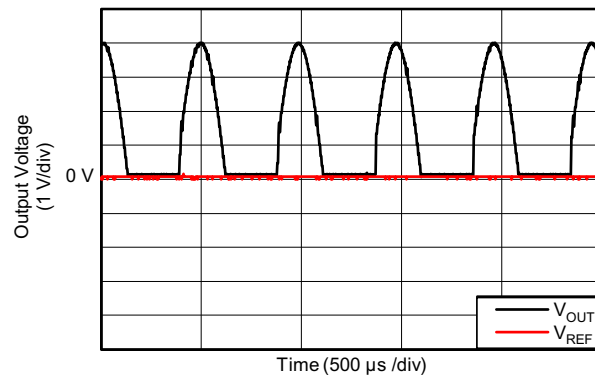
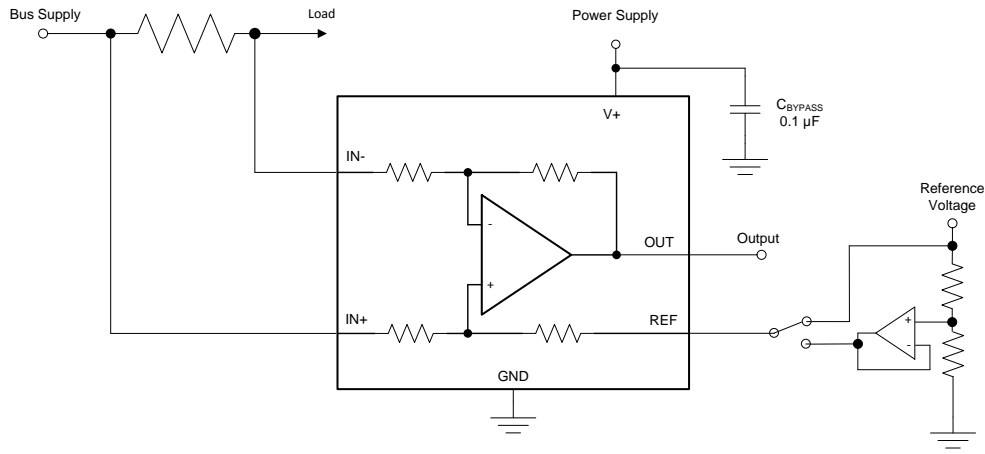

Copyright © 2017, Texas Instruments Incorporated

图 32. Bidirectional Application Schematic

8.2.2.1 Design Requirements

The device is a bidirectional, current-sense amplifier capable of measuring currents through a resistive shunt in two directions. This bidirectional monitoring is common in applications that include charging and discharging operations where the current flow-through resistor can change directions.

8.2.2.2 Detailed Design Procedure

The ability to measure this current flowing in both directions is enabled by applying a voltage to the REF pin, as shown in 图 32. The voltage applied to REF (V_{REF}) sets the output state that corresponds to the zero-input level state. The output then responds by increasing above the V_{REF} value for positive differential signals (relative to the IN- pin) and responds by decreasing below the V_{REF} value for negative differential signals. This reference voltage applied to the REF pin can be set anywhere between 0 V to V_+ . For bidirectional applications, the V_{REF} value is typically set at mid-scale for equal signal range in both current directions. In some cases, however, the V_{REF} value is set at a voltage other than mid-scale when the bidirectional current and corresponding output signal are not required to be symmetrical.

8.2.2.3 Application Curve

图 33 shows an example output response of a bidirectional configuration. With the REF pin connected to a reference voltage, 2.5 V in this case, the output voltage is biased upwards by this reference level. The output rises above the reference voltage for positive differential input signals and falls below the reference voltage for negative differential input signals.



图 33. Bidirectional Application Output Response

9 Power Supply Recommendations

The input circuitry of the INA21x-Q1 family of devices can accurately measure beyond the power-supply voltage, $V+$. For example, the $V+$ power supply can be 5 V, whereas the load power-supply voltage can be as high as 26 V. However, the output voltage range of the OUT pin is limited by the voltages on the power-supply pin. The INA21x-Q1 family of devices can withstand the full input-signal range up to 26 V at the input pins, regardless of whether the device has power applied or not.

10 Layout

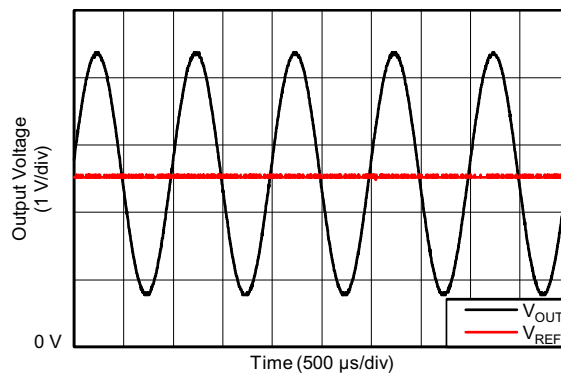
10.1 Layout Guidelines

- Connect the input pins to the sensing resistor using a Kelvin or 4-wire connection. This connection technique ensures that only the current-sensing resistor impedance is detected between the input pins. Poor routing of the current-sensing resistor commonly results in additional resistance present between the input pins. Given the very-low ohmic value of the current resistor, any additional high-current carrying impedance can cause significant measurement errors.
- Place the power-supply bypass capacitor as closely as possible to the supply and ground pins. The recommended value of this bypass capacitor is 0.1 μF . Additional decoupling capacitance can be added to compensate for noisy or high-impedance power supplies.

10.2 Layout Example

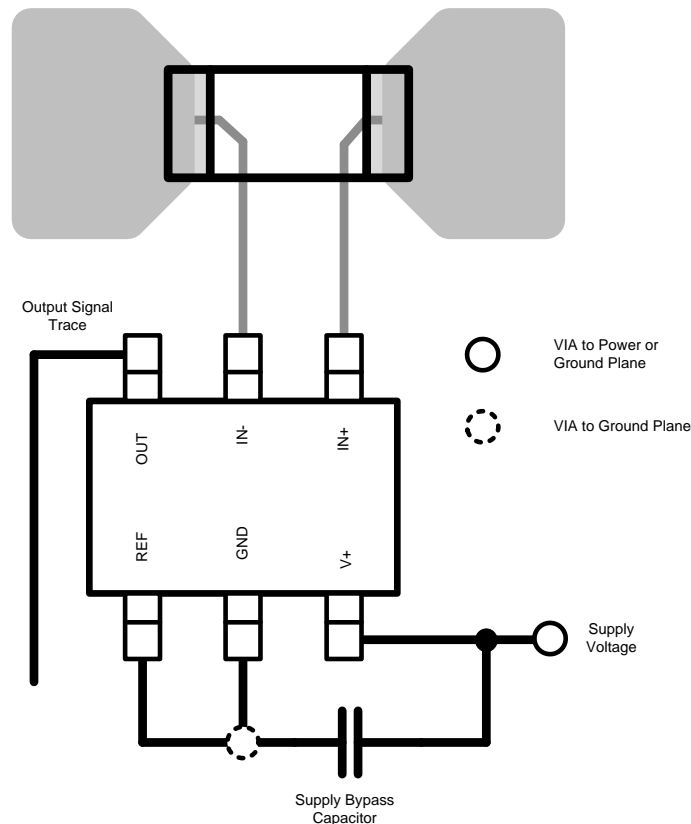

Copyright © 2017, Texas Instruments Incorporated

图 34. Recommended Layout

11 器件和文档支持

11.1 文档支持

11.1.1 相关文档

请参阅如下相关文档：

《[INA210-215EVM 用户指南](#)》（文献编号：SBOU065）

11.2 相关链接

下面的表格列出了快速访问链接。类别包括技术文档、支持与社区资源、工具和软件，以及申请样片或购买产品的快速链接。

表 3. 相关链接

器件	产品文件夹	立即订购	技术文档	工具和软件	支持和社区
INA210-Q1	请单击此处	请单击此处	请单击此处	请单击此处	请单击此处
INA211-Q1	请单击此处	请单击此处	请单击此处	请单击此处	请单击此处
INA212-Q1	请单击此处	请单击此处	请单击此处	请单击此处	请单击此处
INA213-Q1	请单击此处	请单击此处	请单击此处	请单击此处	请单击此处
INA214-Q1	请单击此处	请单击此处	请单击此处	请单击此处	请单击此处
INA215-Q1	请单击此处	请单击此处	请单击此处	请单击此处	请单击此处

11.3 社区资源

下列链接提供到 TI 社区资源的连接。链接的内容由各个分销商“按照原样”提供。这些内容并不构成 TI 技术规范，并且不一定反映 TI 的观点；请参阅 TI 的《[使用条款](#)》。

TI E2E™ 在线社区 *TI 的工程师对工程师 (E2E) 社区*。此社区的创建目的在于促进工程师之间的协作。在 e2e.ti.com 中，您可以咨询问题、分享知识、拓展思路并与同行工程师一道帮助解决问题。

设计支持 *TI 参考设计支持* 可帮助您快速查找有帮助的 E2E 论坛、设计支持工具以及技术支持的联系信息。

11.4 商标

E2E is a trademark of Texas Instruments.
All other trademarks are the property of their respective owners.

11.5 静电放电警告



ESD 可能会损坏该集成电路。德州仪器 (TI) 建议通过适当的预防措施处理所有集成电路。如果不遵守正确的处理措施和安装程序，可能会损坏集成电路。

ESD 的损坏小至导致微小的性能降级，大至整个器件故障。精密的集成电路可能更容易受到损坏，这是因为非常细微的参数更改都可能会导致器件与其发布的规格不相符。

11.6 Glossary

[SLYZ022](#) — *TI Glossary*.

This glossary lists and explains terms, acronyms, and definitions.

12 机械、封装和可订购信息

以下页面包含机械、封装和可订购信息。这些信息是指定器件的最新可用数据。这些数据如有变更，恕不另行通知和修订此文档。如欲获取此产品说明书的浏览器版本，请参阅左侧的导航。

PACKAGING INFORMATION

Orderable Device	Status (1)	Package Type	Package Drawing	Pins	Package Qty	Eco Plan (2)	Lead/Ball Finish (6)	MSL Peak Temp (3)	Op Temp (°C)	Device Marking (4/5)	Samples
INA210BQDCKRQ1	ACTIVE	SC70	DCK	6	3000	Green (RoHS & no Sb/Br)	CU NIPDAU	Level-2-260C-1 YEAR	-40 to 125	13F	Samples
INA210CQDCKRQ1	ACTIVE	SC70	DCK	6	3000	Green (RoHS & no Sb/Br)	CU NIPDAU	Level-2-260C-1 YEAR	-40 to 125	17D	Samples
INA211BQDCKRQ1	ACTIVE	SC70	DCK	6	3000	Green (RoHS & no Sb/Br)	CU NIPDAU	Level-2-260C-1 YEAR	-40 to 125	13G	Samples
INA211CQDCKRQ1	ACTIVE	SC70	DCK	6	3000	Green (RoHS & no Sb/Br)	CU NIPDAU	Level-2-260C-1 YEAR	-40 to 125	17E	Samples
INA212AQDCKRQ1	ACTIVE	SC70	DCK	6	3000	Green (RoHS & no Sb/Br)	CU NIPDAU	Level-2-260C-1 YEAR	-40 to 125	SJW	Samples
INA212BQDCKRQ1	ACTIVE	SC70	DCK	6	3000	Green (RoHS & no Sb/Br)	CU NIPDAU	Level-2-260C-1 YEAR	-40 to 125	13H	Samples
INA212CQDCKRQ1	ACTIVE	SC70	DCK	6	3000	Green (RoHS & no Sb/Br)	CU NIPDAU	Level-2-260C-1 YEAR	-40 to 125	17F	Samples
INA213AQDCKRQ1	ACTIVE	SC70	DCK	6	3000	Green (RoHS & no Sb/Br)	CU NIPDAU	Level-2-260C-1 YEAR	-40 to 125	OBX	Samples
INA213BQDCKRQ1	ACTIVE	SC70	DCK	6	3000	Green (RoHS & no Sb/Br)	CU NIPDAU	Level-2-260C-1 YEAR	-40 to 125	13I	Samples
INA213CQDCKRQ1	ACTIVE	SC70	DCK	6	3000	Green (RoHS & no Sb/Br)	CU NIPDAU	Level-2-260C-1 YEAR	-40 to 125	17G	Samples
INA214AQDCKRQ1	ACTIVE	SC70	DCK	6	3000	Green (RoHS & no Sb/Br)	CU NIPDAU	Level-2-260C-1 YEAR	-40 to 125	OFT	Samples
INA214BQDCKRQ1	ACTIVE	SC70	DCK	6	3000	Green (RoHS & no Sb/Br)	CU NIPDAU	Level-2-260C-1 YEAR	-40 to 125	13J	Samples
INA214CQDCKRQ1	ACTIVE	SC70	DCK	6	3000	Green (RoHS & no Sb/Br)	CU NIPDAU	Level-2-260C-1 YEAR	-40 to 125	17H	Samples
INA215BQDCKRQ1	ACTIVE	SC70	DCK	6	3000	Green (RoHS & no Sb/Br)	CU NIPDAU	Level-2-260C-1 YEAR	-55 to 125	13K	Samples
INA215CQDCKRQ1	ACTIVE	SC70	DCK	6	3000	Green (RoHS & no Sb/Br)	CU NIPDAU	Level-2-260C-1 YEAR	-40 to 125	17I	Samples

(1) The marketing status values are defined as follows:

ACTIVE: Product device recommended for new designs.

LIFEBUY: TI has announced that the device will be discontinued, and a lifetime-buy period is in effect.

NRND: Not recommended for new designs. Device is in production to support existing customers, but TI does not recommend using this part in a new design.

PREVIEW: Device has been announced but is not in production. Samples may or may not be available.

OBSELETE: TI has discontinued the production of the device.

⁽²⁾ **RoHS:** TI defines "RoHS" to mean semiconductor products that are compliant with the current EU RoHS requirements for all 10 RoHS substances, including the requirement that RoHS substance do not exceed 0.1% by weight in homogeneous materials. Where designed to be soldered at high temperatures, "RoHS" products are suitable for use in specified lead-free processes. TI may reference these types of products as "Pb-Free".

RoHS Exempt: TI defines "RoHS Exempt" to mean products that contain lead but are compliant with EU RoHS pursuant to a specific EU RoHS exemption.

Green: TI defines "Green" to mean the content of Chlorine (Cl) and Bromine (Br) based flame retardants meet JS709B low halogen requirements of ≤ 1000 ppm threshold. Antimony trioxide based flame retardants must also meet the ≤ 1000 ppm threshold requirement.

⁽³⁾ MSL, Peak Temp. - The Moisture Sensitivity Level rating according to the JEDEC industry standard classifications, and peak solder temperature.

⁽⁴⁾ There may be additional marking, which relates to the logo, the lot trace code information, or the environmental category on the device.

⁽⁵⁾ Multiple Device Markings will be inside parentheses. Only one Device Marking contained in parentheses and separated by a "~" will appear on a device. If a line is indented then it is a continuation of the previous line and the two combined represent the entire Device Marking for that device.

⁽⁶⁾ Lead/Ball Finish - Orderable Devices may have multiple material finish options. Finish options are separated by a vertical ruled line. Lead/Ball Finish values may wrap to two lines if the finish value exceeds the maximum column width.

Important Information and Disclaimer: The information provided on this page represents TI's knowledge and belief as of the date that it is provided. TI bases its knowledge and belief on information provided by third parties, and makes no representation or warranty as to the accuracy of such information. Efforts are underway to better integrate information from third parties. TI has taken and continues to take reasonable steps to provide representative and accurate information but may not have conducted destructive testing or chemical analysis on incoming materials and chemicals. TI and TI suppliers consider certain information to be proprietary, and thus CAS numbers and other limited information may not be available for release.

In no event shall TI's liability arising out of such information exceed the total purchase price of the TI part(s) at issue in this document sold by TI to Customer on an annual basis.

TAPE AND REEL INFORMATION



QUADRANT ASSIGNMENTS FOR PIN 1 ORIENTATION IN TAPE



*All dimensions are nominal

Device	Package Type	Package Drawing	Pins	SPQ	Reel Diameter (mm)	Reel Width W1 (mm)	A0 (mm)	B0 (mm)	K0 (mm)	P1 (mm)	W (mm)	Pin1 Quadrant
INA210BQDCKRQ1	SC70	DCK	6	3000	178.0	9.0	2.4	2.5	1.2	4.0	8.0	Q3
INA210CQDCKRQ1	SC70	DCK	6	3000	178.0	9.0	2.4	2.5	1.2	4.0	8.0	Q3
INA211BQDCKRQ1	SC70	DCK	6	3000	178.0	9.0	2.4	2.5	1.2	4.0	8.0	Q3
INA211CQDCKRQ1	SC70	DCK	6	3000	178.0	9.0	2.4	2.5	1.2	4.0	8.0	Q3
INA212AQDCKRQ1	SC70	DCK	6	3000	178.0	9.0	2.4	2.5	1.2	4.0	8.0	Q3
INA212BQDCKRQ1	SC70	DCK	6	3000	178.0	9.0	2.4	2.5	1.2	4.0	8.0	Q3
INA212CQDCKRQ1	SC70	DCK	6	3000	178.0	9.0	2.4	2.5	1.2	4.0	8.0	Q3
INA213AQDCKRQ1	SC70	DCK	6	3000	178.0	8.4	2.4	2.5	1.2	4.0	8.0	Q3
INA213AQDCKRQ1	SC70	DCK	6	3000	180.0	8.4	2.47	2.3	1.25	4.0	8.0	Q3
INA213BQDCKRQ1	SC70	DCK	6	3000	178.0	9.0	2.4	2.5	1.2	4.0	8.0	Q3
INA213CQDCKRQ1	SC70	DCK	6	3000	178.0	9.0	2.4	2.5	1.2	4.0	8.0	Q3
INA214AQDCKRQ1	SC70	DCK	6	3000	180.0	8.4	2.47	2.3	1.25	4.0	8.0	Q3
INA214BQDCKRQ1	SC70	DCK	6	3000	178.0	9.0	2.4	2.5	1.2	4.0	8.0	Q3
INA214CQDCKRQ1	SC70	DCK	6	3000	178.0	9.0	2.4	2.5	1.2	4.0	8.0	Q3
INA215BQDCKRQ1	SC70	DCK	6	3000	178.0	9.0	2.4	2.5	1.2	4.0	8.0	Q3
INA215CQDCKRQ1	SC70	DCK	6	3000	178.0	9.0	2.4	2.5	1.2	4.0	8.0	Q3

TAPE AND REEL BOX DIMENSIONS

*All dimensions are nominal

Device	Package Type	Package Drawing	Pins	SPQ	Length (mm)	Width (mm)	Height (mm)
INA210BQDCKRQ1	SC70	DCK	6	3000	180.0	180.0	18.0
INA210CQDCKRQ1	SC70	DCK	6	3000	180.0	180.0	18.0
INA211BQDCKRQ1	SC70	DCK	6	3000	180.0	180.0	18.0
INA211CQDCKRQ1	SC70	DCK	6	3000	180.0	180.0	18.0
INA212AQDCKRQ1	SC70	DCK	6	3000	180.0	180.0	18.0
INA212BQDCKRQ1	SC70	DCK	6	3000	180.0	180.0	18.0
INA212CQDCKRQ1	SC70	DCK	6	3000	180.0	180.0	18.0
INA213AQDCKRQ1	SC70	DCK	6	3000	340.0	340.0	38.0
INA213AQDCKRQ1	SC70	DCK	6	3000	213.0	191.0	35.0
INA213BQDCKRQ1	SC70	DCK	6	3000	180.0	180.0	18.0
INA213CQDCKRQ1	SC70	DCK	6	3000	180.0	180.0	18.0
INA214AQDCKRQ1	SC70	DCK	6	3000	202.0	201.0	28.0
INA214BQDCKRQ1	SC70	DCK	6	3000	180.0	180.0	18.0
INA214CQDCKRQ1	SC70	DCK	6	3000	180.0	180.0	18.0
INA215BQDCKRQ1	SC70	DCK	6	3000	180.0	180.0	18.0
INA215CQDCKRQ1	SC70	DCK	6	3000	180.0	180.0	18.0

DCK (R-PDSO-G6)

PLASTIC SMALL-OUTLINE PACKAGE

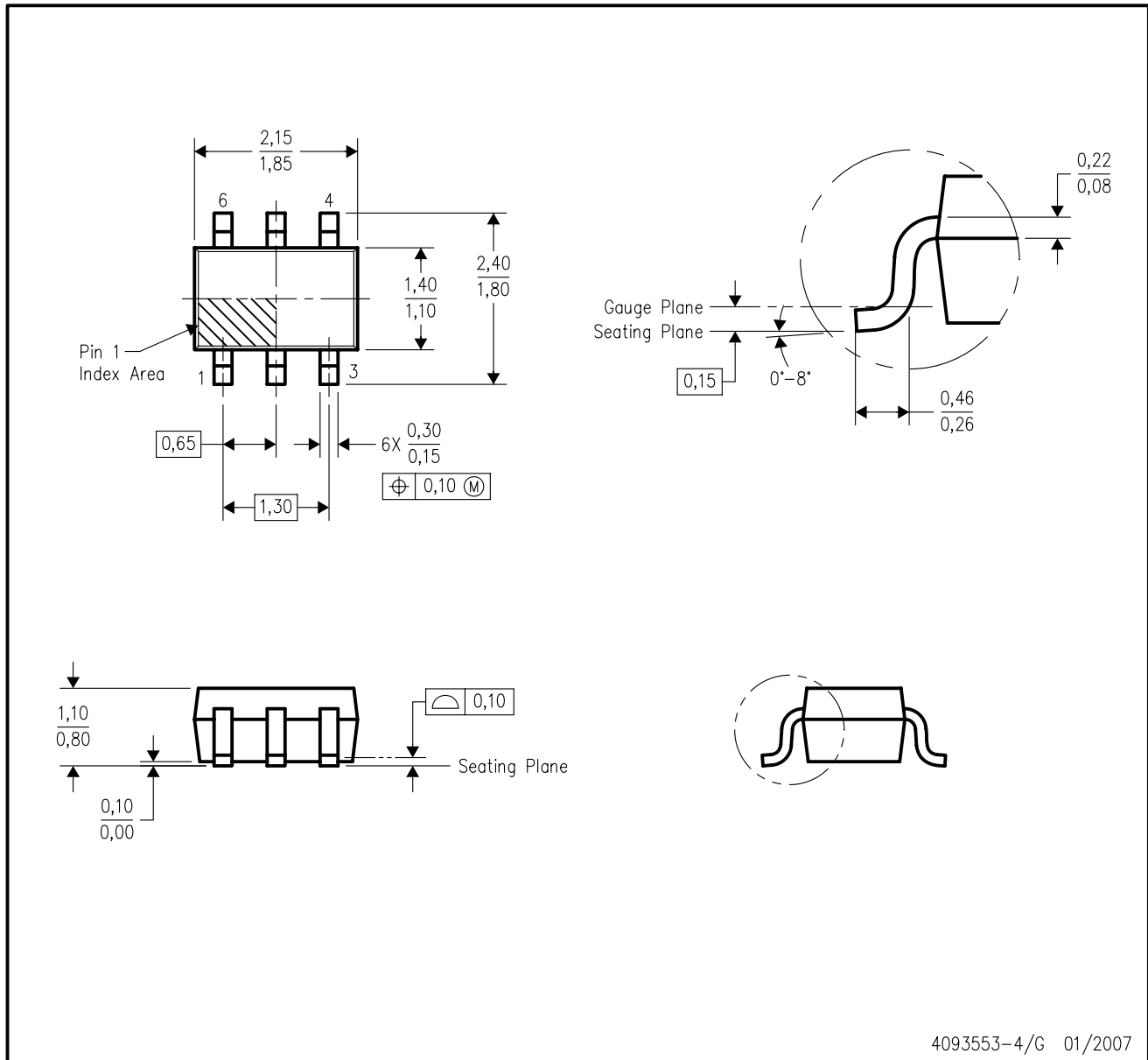

- NOTES:
- A. All linear dimensions are in millimeters.
 - B. This drawing is subject to change without notice.
 - C. Body dimensions do not include mold flash or protrusion. Mold flash and protrusion shall not exceed 0.15 per side.
 - D. Falls within JEDEC MO-203 variation AB.

DCK (R-PDSO-G6)

PLASTIC SMALL OUTLINE

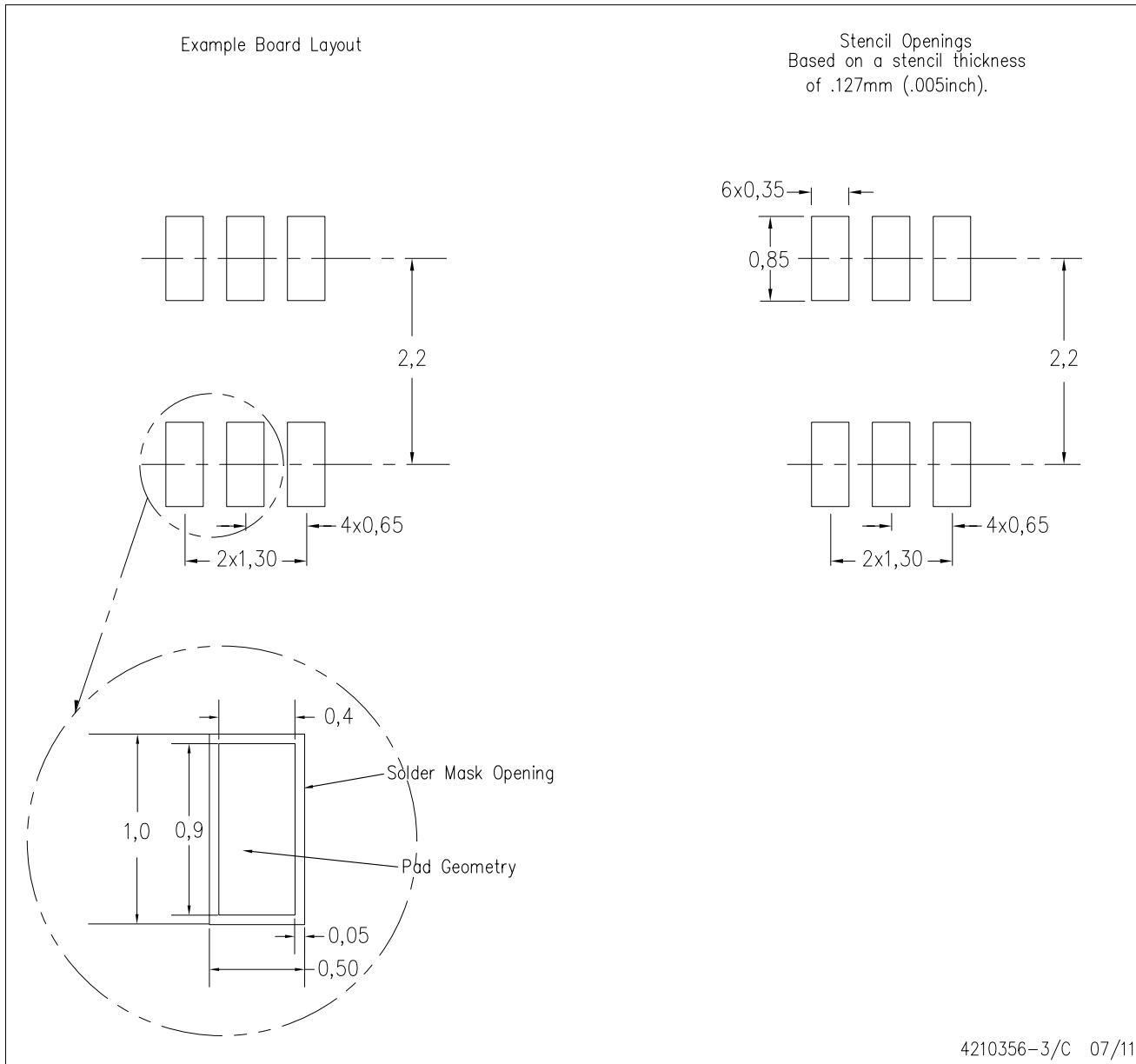

- NOTES:
- All linear dimensions are in millimeters.
 - This drawing is subject to change without notice.
 - Customers should place a note on the circuit board fabrication drawing not to alter the center solder mask defined pad.
 - Publication IPC-7351 is recommended for alternate designs.
 - Laser cutting apertures with trapezoidal walls and also rounding corners will offer better paste release. Customers should contact their board assembly site for stencil design recommendations. Example stencil design based on a 50% volumetric metal load solder paste. Refer to IPC-7525 for other stencil recommendations.

重要声明

德州仪器 (TI) 公司有权按照最新发布的 JESD46 对其半导体产品和服务进行纠正、增强、改进和其他修改，并不再按最新发布的 JESD48 提供任何产品和服务。买方在下订单前应获取最新的相关信息，并验证这些信息是否完整且是最新的。

TI 公布的半导体产品销售条款 (<http://www.ti.com/sc/docs/stdterms.htm>) 适用于 TI 已认证和批准上市的已封装集成电路产品的销售。另有其他条款可能适用于其他类型 TI 产品及服务的使用或销售。

复制 TI 数据表上 TI 信息的重要部分时，不得变更该等信息，且必须随附所有相关保证、条件、限制和通知，否则不得复制。TI 对该等复制文件不承担任何责任。第三方信息可能受到其它限制条件的制约。在转售 TI 产品或服务时，如果存在对产品或服务参数的虚假陈述，则会失去相关 TI 产品或服务的明示或暗示保证，且构成不公平的、欺诈性商业行为。TI 对此类虚假陈述不承担任何责任。

买方和在系统中整合 TI 产品的其他开发人员（总称“设计人员”）理解并同意，设计人员在设计应用时应自行实施独立的分析、评价和判断，且应全权负责并确保应用的安全性，及设计人员的应用（包括应用中使用的 TI 产品）应符合所有适用的法律法规及其他相关要求。设计人员就自己设计的应用声明，其具备制订和实施下列保障措施所需的一切必要专业知识，能够 (1) 预见故障的危险后果，(2) 监视故障及其后果，以及 (3) 降低可能导致危险的故障几率并采取适当措施。设计人员同意，在使用或分发包含 TI 产品的任何应用前，将彻底测试该等应用和和该等应用所用 TI 产品的功能而设计。

TI 提供技术、应用或其他设计建议、质量特点、可靠性数据或其他服务或信息，包括但不限于与评估模块有关的参考设计和材料（总称“TI 资源”），旨在帮助设计人员开发整合了 TI 产品的应用，如果设计人员（个人，或如果是代表公司，则为设计人员的公司）以任何方式下载、访问或使用任何特定的 TI 资源，即表示其同意仅为该等目标，按照本通知的条款使用任何特定 TI 资源。

TI 所提供的 TI 资源，并未扩大或以其他方式修改 TI 对 TI 产品的公开适用的质保及质保免责声明；也未导致 TI 承担任何额外的义务或责任。TI 有权对其 TI 资源进行纠正、增强、改进和其他修改。除特定 TI 资源的公开文档中明确列出的测试外，TI 未进行任何其他测试。

设计人员只有在开发包含该等 TI 资源所列 TI 产品的应用时，才被授权使用、复制和修改任何相关单项 TI 资源。但并未依据禁止反言原则或其他法律授予您任何 TI 知识产权的任何其他明示或默示的许可，也未授予您 TI 或第三方的任何技术或知识产权的许可，该等许可包括但不限于任何专利权、版权、屏蔽作品权或与应用 TI 产品或服务的任何整合、机器制作、流程相关的其他知识产权。涉及或参考了第三方产品或服务的信息不构成使用此类产品或服务的许可或与其相关的保证或认可。使用 TI 资源可能需要您向第三方获得对该等第三方专利或其他知识产权的许可。

TI 资源系“按原样”提供。TI 兹免除对资源及其使用作出所有其他明确或默示的保证或陈述，包括但不限于对准确性或完整性、产权保证、无屡发故障保证，以及适销性、适合特定用途和不侵犯任何第三方知识产权的任何默认保证。TI 不负责任何申索，包括但不限于因组合产品所致或与之有关的申索，也不为或对设计人员进行辩护或赔偿，即使该等产品组合已列于 TI 资源或其他地方。对因 TI 资源或其使用引起或与之有关的任何实际的、直接的、特殊的、附带的、间接的、惩罚性的、偶发的、从属或惩戒性损害赔偿，不管 TI 是否获悉可能会产生上述损害赔偿，TI 概不负责。

除 TI 已明确指出特定产品已达到特定行业标准（例如 ISO/TS 16949 和 ISO 26262）的要求外，TI 不对未达到任何该等行业标准要求而承担任何责任。

如果 TI 明确宣称产品有助于功能安全或符合行业功能安全标准，则该等产品旨在帮助客户设计和创作自己的符合相关功能安全标准和要求的的应用。在应用内使用产品的行为本身不会配有 任何安全特性。设计人员必须确保遵守适用于其应用的相关安全要求和标准而设计。设计人员不可将任何 TI 产品用于关乎性命的医疗设备，除非已由各方获得授权的管理人员签署专门的合同对此类应用专门作出规定。关乎性命的医疗设备是指出现故障会导致严重身体伤害或死亡的医疗设备（例如生命保障设备、心脏起搏器、心脏除颤器、人工心脏泵、神经刺激器以及植入设备）。此类设备包括但不限于，美国食品药品监督管理局认定为 III 类设备的设备，以及在美国以外的其他国家或地区认定为同等类别设备的所有医疗设备。

TI 可能明确指定某些产品具备某些特定资格（例如 Q100、军用级或增强型产品）。设计人员同意，其具备一切必要专业知识，可以为自己的应用选择适合的产品，并且正确选择产品的风险由设计人员承担。设计人员单方面负责遵守与该等选择有关的所有法律或监管要求。

设计人员同意向 TI 及其代表全额赔偿因其不遵守本通知条款和条件而引起的任何损害、费用、损失和/或责任。

邮寄地址：上海市浦东新区世纪大道 1568 号中建大厦 32 楼，邮政编码：200122
Copyright © 2018 德州仪器半导体技术（上海）有限公司