

OPA2277-EP 高精度、低噪声运算放大器

1 特性

- 超低偏移电压：10 μ V
- 高开环增益：134dB
- 高共模抑制比：140dB
- 高电源抑制比：130dB
- 低偏置电流：1nA（最大值）
- 宽电源电压范围： ± 2 V 至 ± 18 V
- 低静态电流：800 μ A/放大器
- 支持国防、航天和医疗应用
 - 受控基线
 - 同一组装和测试场所
 - 同一制造场所
 - 支持军用（-55 $^{\circ}$ C 至 125 $^{\circ}$ C）温度范围⁽¹⁾
 - 延长的产品生命周期
 - 延长的产品变更通知
 - 产品可追溯性

2 应用范围

- 换能器放大器
- 桥式放大器
- 温度测量
- 应变仪放大器
- 精密积分器
- 电池供电仪器
- 测试设备

(1) 欲了解其他可用温度范围，请与厂家联系

4 称重放大器原理图

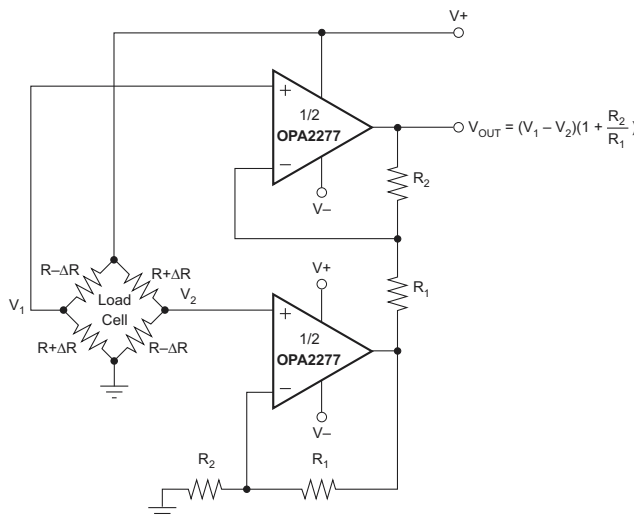

3 说明

OPA2277 高精度运算放大器取代了行业标准的 OP-177。此器件改进了噪声性能，具有更宽的输出电压摆幅，并且在使静态电流减半的同时将速度提升了一倍。其具有诸多特性，其中包括超低的偏移电压、超低漂移、低偏置电流、高共模抑制比及高电源抑制比。

OPA2277 由 ± 2 V 至 ± 18 V 电源供电运行，性能出色。大多数运算放大器仅有一个指定的电源电压，而 OPA2277 有所不同，其电源电压取决于实际应用；唯一的限制条件是电源电压在 ± 5 V 至 ± 15 V 范围内。当放大器输出摆幅达到指定限值时，可保持高性能。由于初始偏移电压非常低（最高 ± 20 μ V），因此通常无需用户调整。

OPA2277 易于使用，而且不存在某些运算放大器中会出现的反相和过载问题。其单位增益稳定，在宽范围负载条件下可保持出色的动态性能。OPA2277 具有完全独立的电路，即便在过驱或过载时也可以实现最低串扰和零交互。该器件提供 DIP-8 和 SO-8 两种封装。OPA2277 的额定工作温度范围为 -55 $^{\circ}$ C 至 125 $^{\circ}$ C。

器件信息⁽¹⁾

订货编号	封装	封装尺寸（标称值）
OPA2277MDTEP	SOIC (8)	3.91mm x 4.90mm

(1) 要了解所有可用封装，请见数据表末尾的可订购产品附录。



目录

1	特性	1	8.2	Functional Block Diagram	11
2	应用范围	1	8.3	Feature Description	11
3	说明	1	9	Application and Implementation	12
4	称重放大器原理图	1	9.1	Application Information	12
5	修订历史记录	2	9.2	Typical Application	12
6	Pin Configuration and Functions	3	10	Power Supply Recommendations	15
7	Specifications	4	11	Layout	15
7.1	Absolute Maximum Ratings	4	11.1	Layout Guidelines	15
7.2	ESD Ratings	4	11.2	Layout Example	15
7.3	Recommended Operating Conditions	4	12	器件和文档支持	17
7.4	Thermal Information	4	12.1	商标	17
7.5	Electrical Characteristics	5	12.2	静电放电警告	17
7.6	Typical Characteristics	7	12.3	术语表	17
8	Detailed Description	11	13	机械封装和可订购信息	17
8.1	Overview	11			

5 修订历史记录

日期	修订版本	注释
2014年12月	*	最初发布。

6 Pin Configuration and Functions

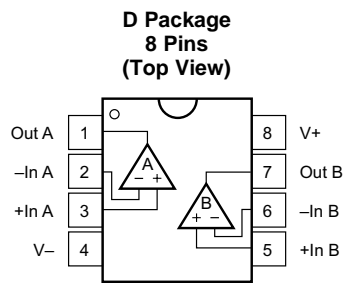

Pin Functions

PIN		I/O	DESCRIPTION
NAME	NO.		
OUT A	1	O	Amplifier output A
-IN A	2	I	Inverting amplifier input A
+IN A	3	I	Non-inverting amplifier input A
V-	4	I	Negative amplifier power supply input
+IN B	5	I	Non-inverting amplifier input B
-IN B	6	I	Inverting amplifier input B
OUT B	7	O	Amplifier output B
V+	8	I	Positive amplifier power supply input

7 Specifications

7.1 Absolute Maximum Ratings⁽¹⁾

over operating free-air temperature (unless otherwise noted)

	MIN	MAX	UNIT
Supply voltage		36	V
Input voltage	(V-) – 0.7	(V+) + 0.7	V
Output short-circuit (to ground) ⁽²⁾	Continuous		
Operating temperature	–55	125	°C
Junction temperature		150	°C
Lead temperature (soldering, 10 s)		300	°C
T _{stg} Storage temperature range	–55	125	°C

(1) Stresses beyond those listed under *absolute maximum ratings* may cause permanent damage to the device. These are stress ratings only, and functional operation of the device at these or any other conditions beyond those indicated under *recommended operating conditions* is not implied. Exposure to absolute-maximum-rated conditions for extended periods may affect device reliability.

(2) One channel per package.

7.2 ESD Ratings

		VALUE	UNIT
V _(ESD) Electrostatic discharge	Human body model (HBM), per ANSI/ESDA/JEDEC JS-001, all pins ⁽¹⁾	±2000	V
	Machine model (MM)	±100	

(1) JEDEC document JEP155 states that 500-V HBM allows safe manufacturing with a standard ESD control process.

7.3 Recommended Operating Conditions

over operating free-air temperature range (unless otherwise noted)

		MIN	NOM	MAX	UNIT
V _S Specified voltage range		±5		±15	V
	Operating voltage range	±2		±18	V
T _J Operating junction temperature		–55		125	°C

7.4 Thermal Information

THERMAL METRIC ⁽¹⁾		OPA2277	UNIT
		D	
		8 PINS	
R _{θJA}	Junction-to-ambient thermal resistance	91.9	°C/W
R _{θJC(top)}	Junction-to-case (top) thermal resistance	39.9	
R _{θJB}	Junction-to-board thermal resistance	40.6	
ψ _{JT}	Junction-to-top characterization parameter	3.9	
ψ _{JB}	Junction-to-board characterization parameter	39.6	
R _{θJC(bot)}	Junction-to-case (bottom) thermal resistance	N/A	

(1) For more information about traditional and new thermal metrics, see the *IC Package Thermal Metrics* application report, [SPRA953](#).

7.5 Electrical Characteristics

At $T_A = 25^\circ\text{C}$, $V_S = \pm 5\text{ V}$ to $\pm 15\text{ V}$, $R_L = 2\text{ k}\Omega$ (unless otherwise noted).

PARAMETER		TEST CONDITIONS	MIN	TYP	MAX	UNIT
OFFSET VOLTAGE						
V_{OS}	Input offset voltage			± 20	± 65	μV
	vs temperature, $T_J = -55^\circ\text{C}$ to 125°C				± 150	μV
	vs temperature (dV_{OS}/dT), $T_J = -55^\circ\text{C}$ to 125°C			± 0.15		$\mu\text{V}/^\circ\text{C}$
	vs power supply (PSRR)	$V_S = \pm 2\text{ V}$ to $\pm 18\text{ V}$		± 0.3	± 1	$\mu\text{V}/\text{V}$
	$T_J = -55^\circ\text{C}$ to 125°C	$V_S = \pm 2\text{ V}$ to $\pm 18\text{ V}$			± 1	$\mu\text{V}/\text{V}$
	vs time			0.2		$\mu\text{V}/\text{mo}$
	Channel separation (dual)	dc		0.1		$\mu\text{V}/\text{V}$
INPUT BIAS CURRENT						
I_B	Input bias current			± 0.5	± 2.8	nA
	$T_J = -55^\circ\text{C}$ to 125°C				± 7	
I_{OS}	Input offset current			± 0.5	± 2.8	nA
	$T_J = -55^\circ\text{C}$ to 125°C				± 7	
NOISE						
Input voltage noise, $f = 0.1$ to 10 Hz				0.22		μV_{pp}
				0.035		μV_{rms}
e_n	Input voltage noise density	$f = 10\text{ Hz}$		12		nV/ $\sqrt{\text{Hz}}$
		$f = 100\text{ Hz}$		8		
		$f = 1\text{ Hz}$		8		
		$f = 10\text{ Hz}$		8		
i_n	Current noise density	$f = 1\text{ kHz}$		0.2		pA/ $\sqrt{\text{Hz}}$
INPUT VOLTAGE RANGE						
V_{CM}	Common-mode voltage range			$(V_-) + 2$	$(V_+) - 2$	V
CMRR	Common-mode rejection $T_J = -55^\circ\text{C}$ to 125°C	$V_{CM} = (V_-) + 2\text{ V}$ to $(V_+) - 2\text{ V}$		115	140	dB
		$V_{CM} = (V_-) + 2\text{ V}$ to $(V_+) - 2\text{ V}$		115		dB
INPUT IMPEDANCE						
	Differential			100 3		$\text{M}\Omega$ pF
	Common-mode	$V_{CM} = (V_-) + 2\text{ V}$ to $(V_+) - 2\text{ V}$		250 3		$\text{G}\Omega$ pF
OPEN-LOOP GAIN						
A_{OL}	Open-loop voltage gain $T_J = -55^\circ\text{C}$ to 125°C	$V_O = (V_-) + 0.5\text{ V}$ to $(V_+) - 1.2\text{ V}$, $R_L = 10\text{ k}\Omega$		140		dB
		$V_O = (V_-) + 1.5\text{ V}$ to $(V_+) - 1.5\text{ V}$, $R_L = 2\text{ k}\Omega$		126	134	
		$V_O = (V_-) + 1.5\text{ V}$ to $(V_+) - 1.5\text{ V}$, $R_L = 2\text{ }\Omega$		126		
FREQUENCY RESPONSE						
GBW	Gain bandwidth product			1		MHz
SR	Slew rate			0.8		V/ μs
	Settling time	0.1%	$V_S = \pm 15\text{ V}$, $G = 1$, 10-V step	14		μs
		0.01%	$V_S = \pm 15\text{ V}$, $G = 1$, 10-V step	16		μs
	Overload recovery time	$V_{IN} \times G = V_S$		3		μs
	Total harmonic distortion + noise (THD + N)	$f = 1\text{ kHz}$, $G = 1$, $V_O = 3.5\text{ V}_{rms}$		0.002%		

Electrical Characteristics (continued)

 At $T_A = 25^\circ\text{C}$, $V_S = \pm 5\text{ V}$ to $\pm 15\text{ V}$, $R_L = 2\text{ k}\Omega$ (unless otherwise noted).

PARAMETER		TEST CONDITIONS	MIN	TYP	MAX	UNIT
OUTPUT						
V_O	Voltage output	$R_L = 10\text{ k}\Omega$	$(V_-) + 0.5$	$(V_+) - 1.2$		V
		$R_L = 10\text{ k}\Omega$, $T_J = -55^\circ\text{C}$ to 125°C	$(V_-) + 0.5$	$(V_+) - 1.2$		
		$R_L = 2\text{ k}\Omega$	$(V_-) + 1.5$	$(V_+) - 1.5$		
		$R_L = 2\text{ k}\Omega$, $T_J = -55^\circ\text{C}$ to 125°C	$(V_-) + 1.5$	$(V_+) - 1.5$		
I_{SC}	Short-circuit current			± 35		mA
C_{LOAD}	Capacitive load drive		See Typical Characteristics			
POWER SUPPLY						
V_S	Specified voltage range		± 5		± 15	V
	Operating voltage range		± 2		± 18	V
I_Q	Quiescent current (per amplifier) $T_J = -55^\circ\text{C}$ to 125°C	$I_O = 0\text{ A}$		± 790	± 825	μA
		$I_O = 0\text{ A}$			± 900	μA
TEMPERATURE RANGE						
	Specified temperature range		-55		125	$^\circ\text{C}$
	Operating temperature range		-55		125	$^\circ\text{C}$
T_{stg}	Storage temperature range		-55		125	$^\circ\text{C}$

7.6 Typical Characteristics

At $T_A = 25^\circ\text{C}$, $V_S = \pm 15\text{ V}$, and $R_L = 2\text{ k}\Omega$, unless otherwise noted.

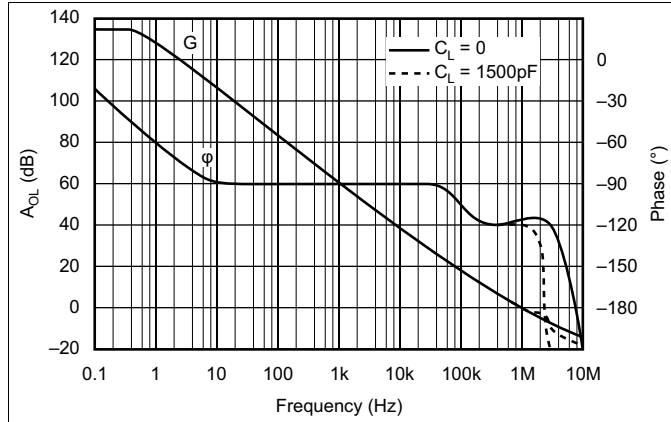

Figure 1. Open-Loop Gain/Phase vs Frequency

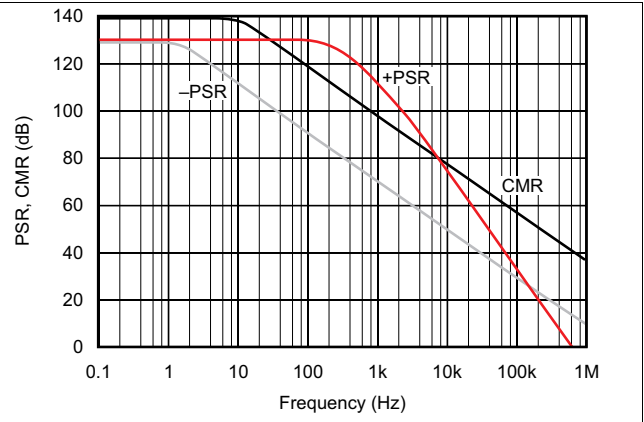

Figure 2. Power Supply and Common-Mode Rejection vs Frequency

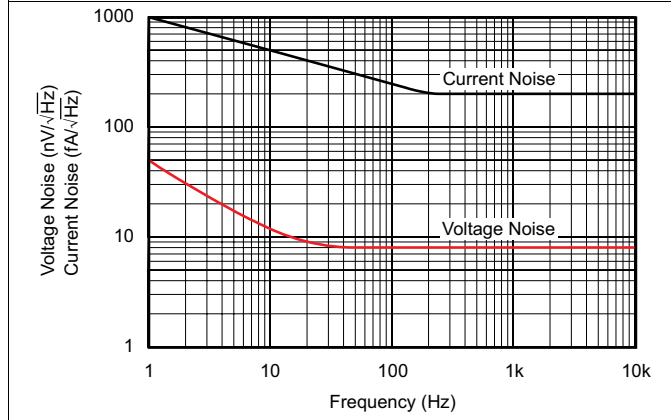

Figure 3. Input Noise and Current Noise Spectral Density vs Frequency

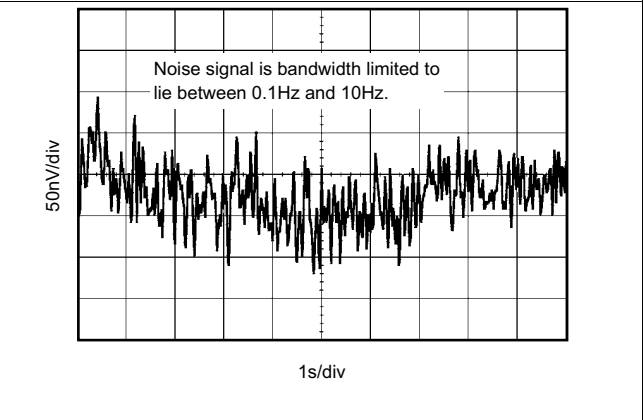

Figure 4. Input Noise Voltage vs Time

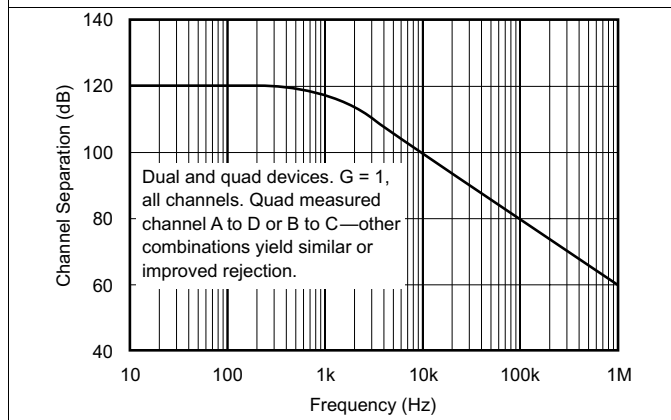
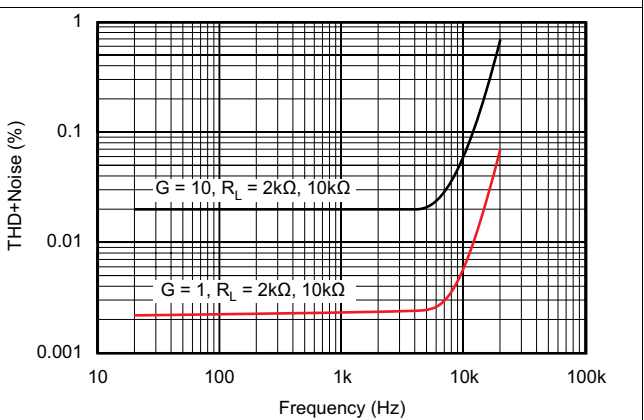

Figure 5. Channel Separation vs Frequency



$V_{OUT} = 3.5\text{ Vrms}$

Figure 6. Total Harmonic Distortion + Noise vs Frequency

Typical Characteristics (continued)

At $T_A = 25^\circ\text{C}$, $V_S = \pm 15\text{ V}$, and $R_L = 2\text{ k}\Omega$, unless otherwise noted.

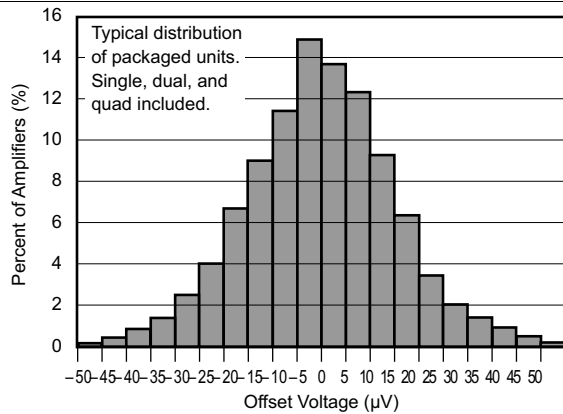

Figure 7. Offset Voltage Production Distribution

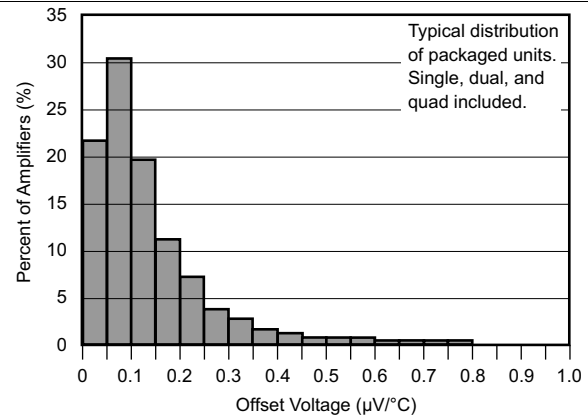

Figure 8. Offset Voltage Drift Production Distribution

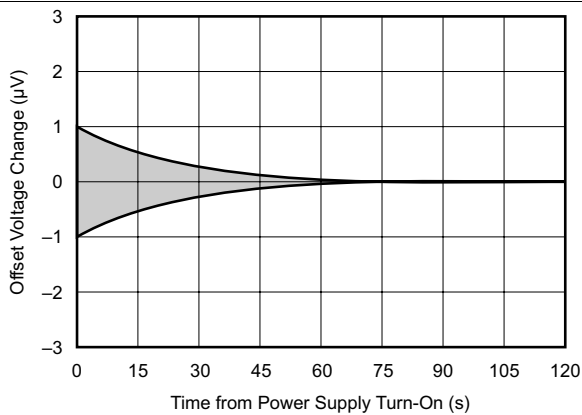

Figure 9. Warm-Up Offset Voltage Drift

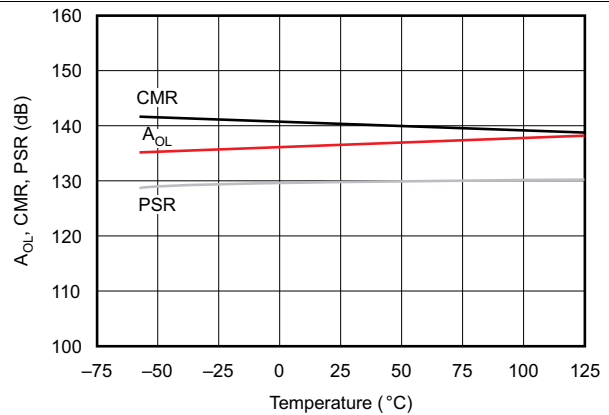

Figure 10. A_{OL} , CMR, PSR vs Temperature

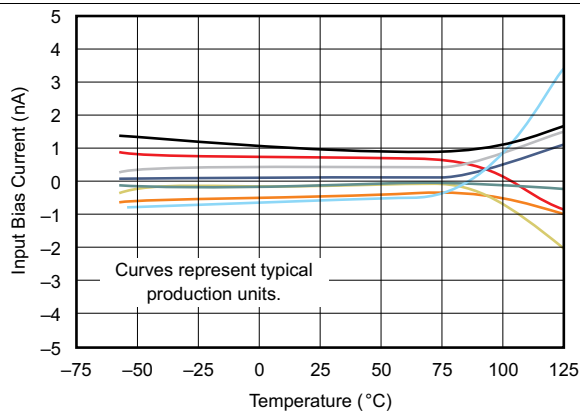

Figure 11. Input Bias Current vs Temperature

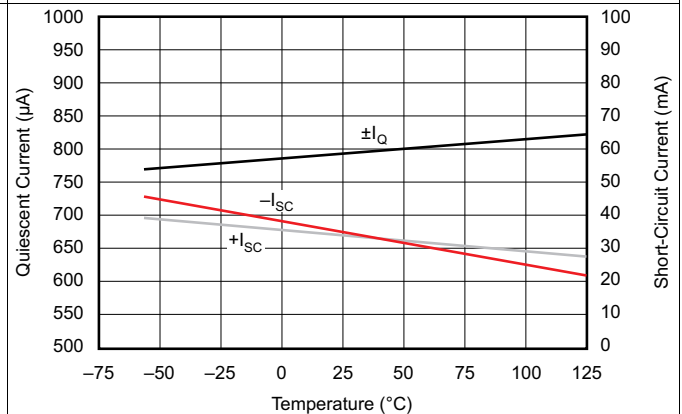

Figure 12. Quiescent Current and Short-Circuit Current vs Temperature

Typical Characteristics (continued)

At $T_A = 25^\circ\text{C}$, $V_S = \pm 15\text{ V}$, and $R_L = 2\text{ k}\Omega$, unless otherwise noted.

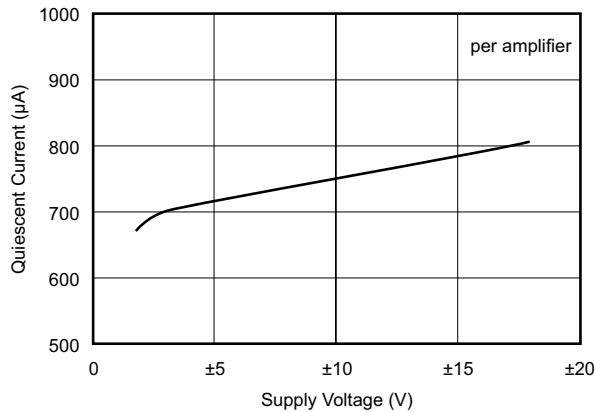

Figure 13. Quiescent Current vs Supply Voltage

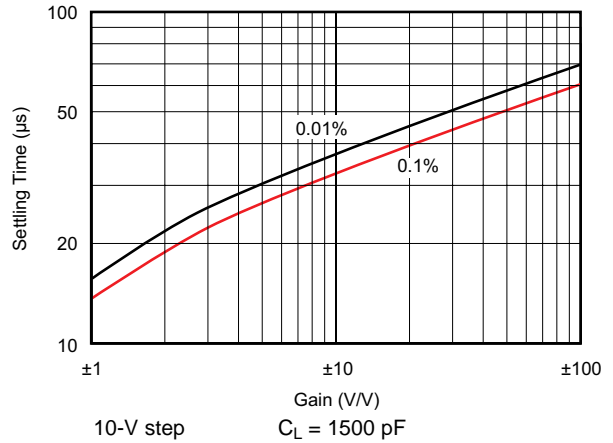

Figure 14. Settling Time vs Closed-Loop Gain

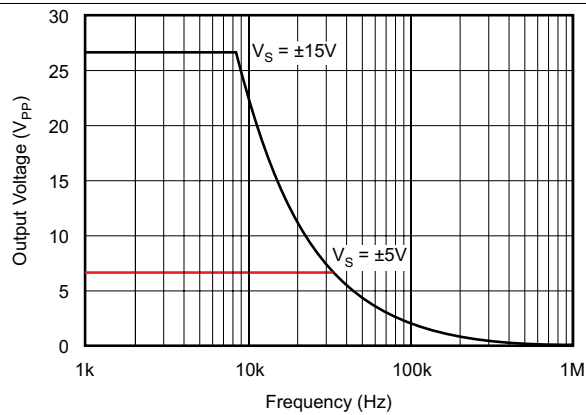

Figure 15. Maximum Output Voltage vs Frequency

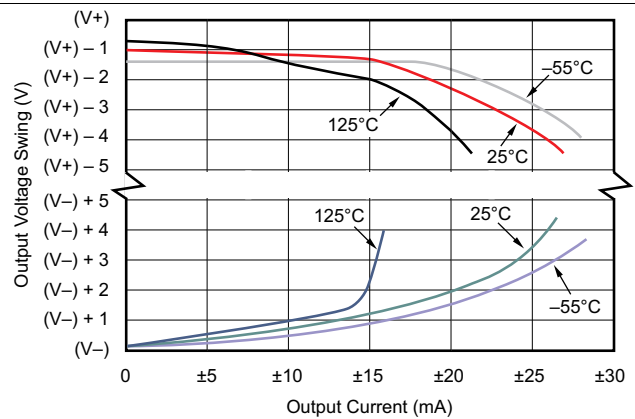

Figure 16. Output Voltage Swing vs Output Current

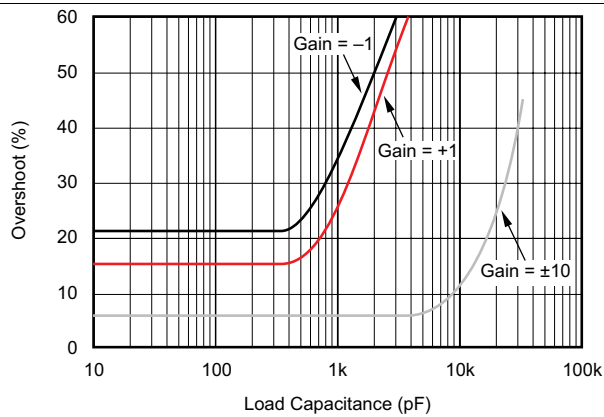

Figure 17. Small-Signal Overshoot vs Load Capacitance

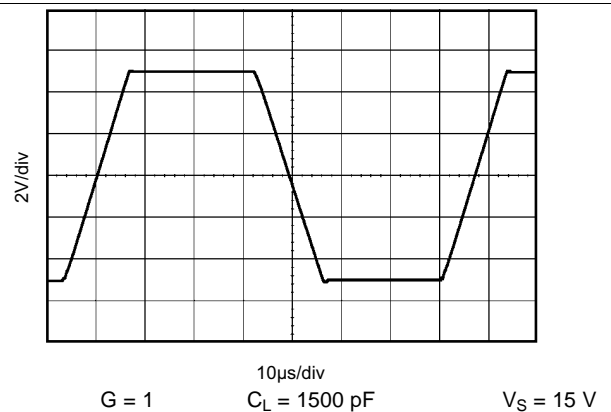
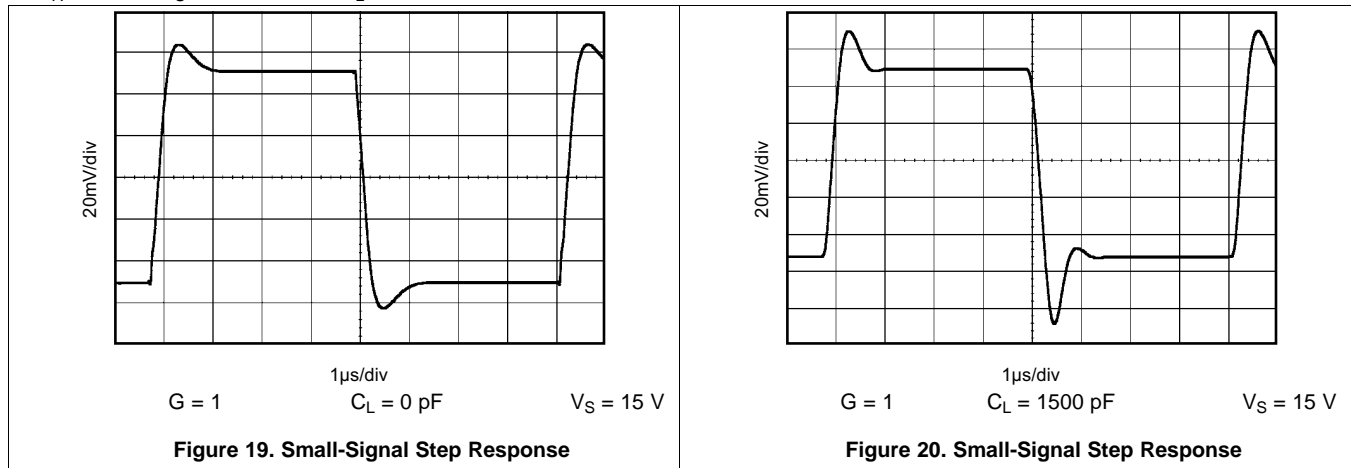

Figure 18. Large-Signal Step Response

Typical Characteristics (continued)

At $T_A = 25^\circ\text{C}$, $V_S = \pm 15\text{ V}$, and $R_L = 2\text{ k}\Omega$, unless otherwise noted.



8 Detailed Description

8.1 Overview

The OPA2277 is a unity-gain stable, high-precision, and low-noise operational amplifier. OPA2277 operates from ± 2 - to ± 18 -V supplies with excellent performance. Unlike most operational amplifiers which are specified at only one supply voltage, the OPA2277 is specified for real-world applications; a single limit applies over the ± 5 - to ± 15 -V supply range. High performance is maintained as the amplifiers swing to their specified limit. Because the initial offset voltage (± 50 - μ V max) is so low, user adjustment is usually not required.

8.2 Functional Block Diagram

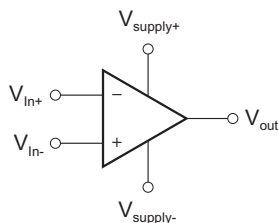

8.3 Feature Description

The OPA2277 precision operational amplifier replaces the industry standard OP-177. It offers improved noise, wider output voltage swing, and is twice as fast with half the quiescent current. Features include ultra-low offset voltage and drift, low bias current, high common-mode rejection, and high power-supply rejection.

OPA2277 is easy to use and free from phase inversion and overload problems found in some operational amplifiers. It is stable in unity gain and provides excellent dynamic behavior over a wide range of load conditions. OPA2277 features completely independent circuitry for lowest crosstalk and freedom from interaction, even when overdriven or overloaded.

9 Application and Implementation

NOTE

Information in the following applications sections is not part of the TI component specification, and TI does not warrant its accuracy or completeness. TI's customers are responsible for determining suitability of components for their purposes. Customers should validate and test their design implementation to confirm system functionality.

9.1 Application Information

The OPA2277 is unity-gain stable and free from unexpected output phase reversal, making it easy to use in a wide range of applications. Applications with noisy or high-impedance power supplies may require decoupling capacitors close to the device pins. In most cases, 0.1-μF capacitors are adequate.

9.2 Typical Application

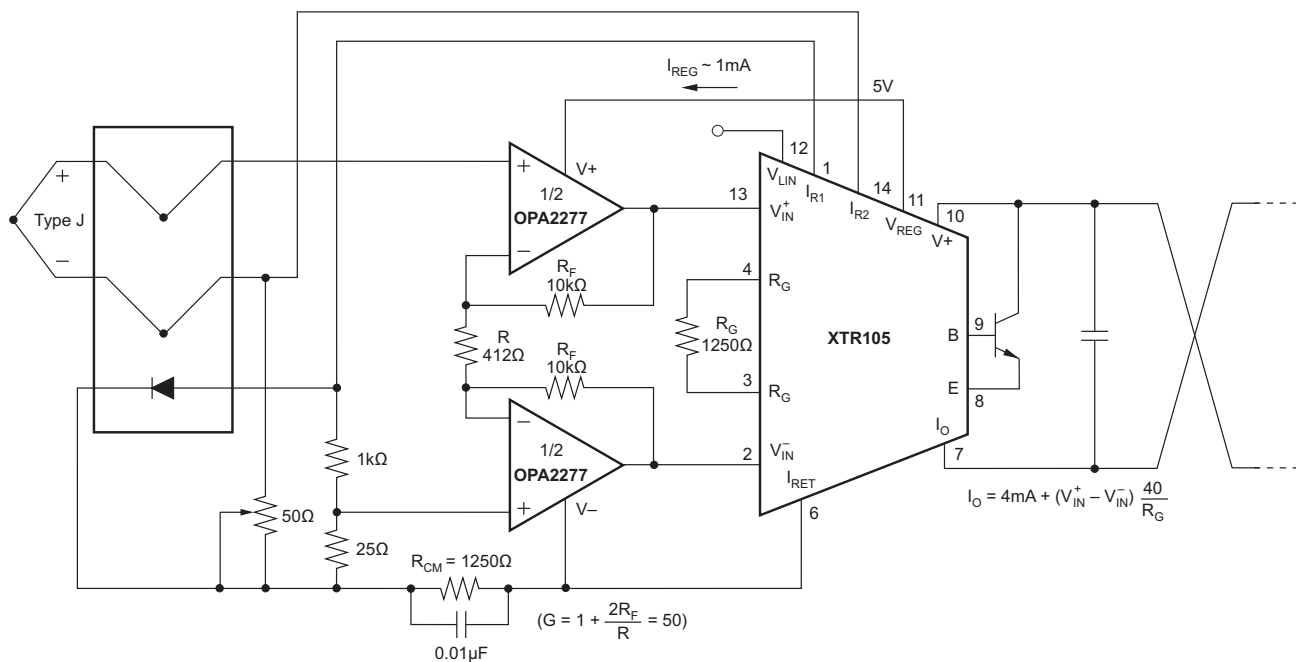

Figure 21. Thermocouple Low-Offset, Low-Drift Loop Measurement With Diode Cold Junction Compensation

9.2.1 Design Requirements

For the thermocouple low-offset, low-drift loop measurement with diode cold junction compensation (see Figure 21), Table 1 lists the design parameters needed with gain = 50.

$$G = 1 + \frac{2R_F}{R} = 50 \tag{1}$$

Table 1. Design Parameters

DESIGN PARAMETER	EXAMPLE VALUE
R _F	10 kΩ
R	412 Ω

9.2.2 Detailed Design Procedure

9.2.2.1 Offset Voltage Adjustment

The OPA2277 is laser-trimmed for very-low offset voltage and drift so most circuits do not require external adjustment. However, offset voltage trim connections are provided on pins 1 and 8. Offset voltage can be adjusted by connecting a potentiometer as shown in Figure 22. Only use this adjustment to null the offset of the operational amplifier. Do not use this adjustment to compensate for offsets created elsewhere in a system because this can introduce additional temperature drift.

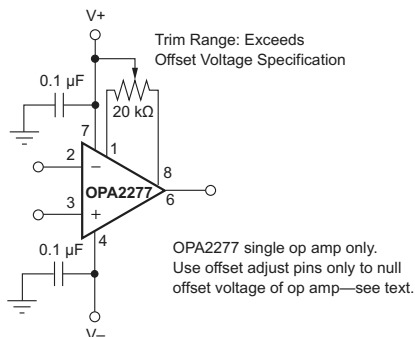

Figure 22. OPA2277 Offset Voltage Trim Circuit

9.2.2.2 Input Protection

The inputs of the OPA2277 are protected with 1-kΩ series input resistors and diode clamps. The inputs can withstand ±30-V differential inputs without damage. The protection diodes conduct current when the inputs are overdriven. This may disturb the slewing behavior of unity-gain follower applications, but does not damage the operational amplifier.

9.2.2.3 Input Bias Current Cancellation

The input stage base current of the OPA2277 is internally compensated with an equal and opposite cancellation circuit. The resulting input bias current is the difference between the input stage base current and the cancellation current. This residual input bias current can be positive or negative.

When the bias current is canceled in this manner, the input bias current and input offset current are approximately the same magnitude. As a result, it is not necessary to use a bias current cancellation resistor as is often done with other operational amplifiers (see Figure 23). A resistor added to cancel input bias current errors may actually increase offset voltage and noise.

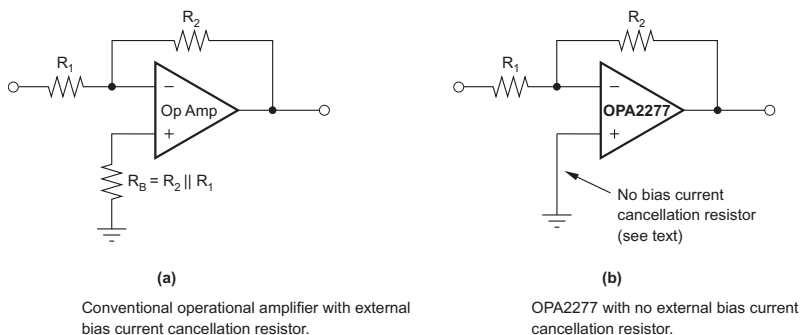
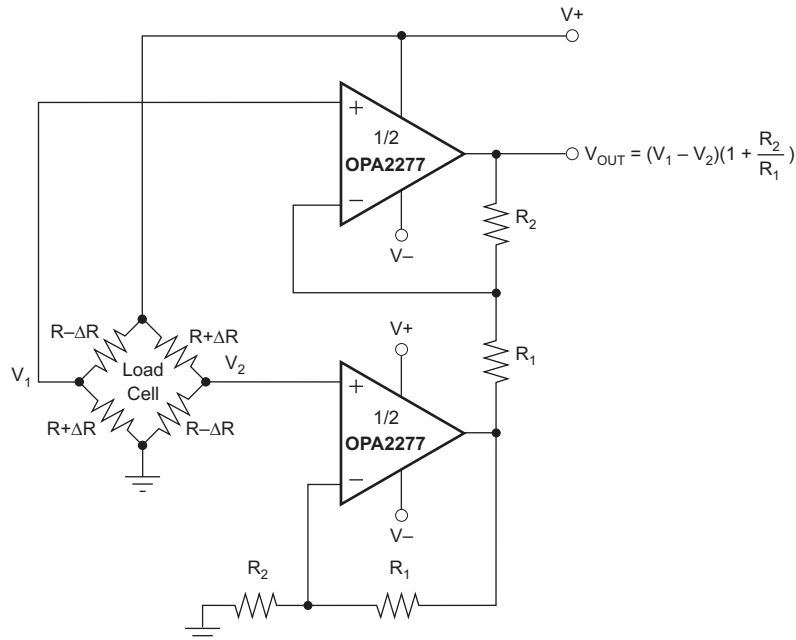

Figure 23. Input Bias Current Cancellation



A. For integrated solution see: INA126, INA2126 (dual), INA125 (on-board reference), or INA122 (single-supply).

Figure 24. Load Cell Amplifier

9.2.3 Application Curves

At $T_J = 25^\circ\text{C}$, $V_S = \pm 15\text{ V}$, and $R_L = 2\text{ k}\Omega$. **Figure 25** shows Change in input bias current versus power supply voltage. Curve shows normalized change in bias current with respect to $V_S = \pm 10\text{ V}$ (+20 V). Typical I_B may range from -0.5 to 0.5 nA at $V_S = \pm 10\text{ V}$. **Figure 26** shows change in input bias current versus common-mode voltage. Curve shows normalized change in bias current with respect to $V_{CM} = 0\text{ V}$. Typical I_B may range from -0.5 to 0.5 nA at $V_{CM} = 0\text{ V}$.

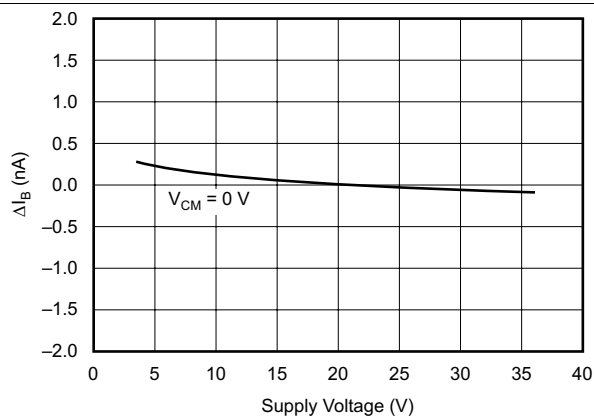

Figure 25. Change in Input Bias Current vs Power Supply Voltage

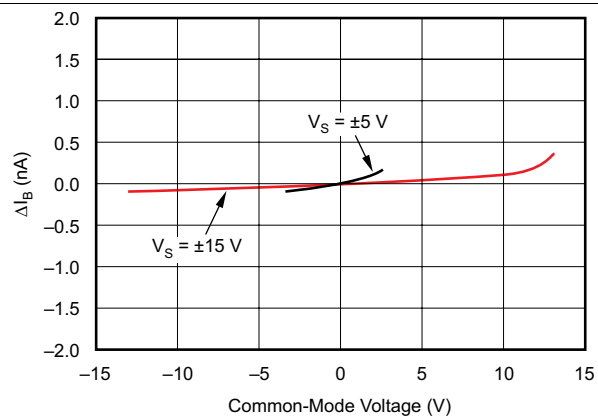

Figure 26. Change in Input Bias Current vs Common-Mode Voltage

10 Power Supply Recommendations

The OPA2277 operational amplifier operates from ± 2.5 - to ± 18 -V supplies with excellent performance. Unlike most operational amplifiers which are specified at only one supply voltage, the OPA2277 is specified for real-world applications. A single set of specifications applies over the ± 5 - to ± 15 -V supply range. Specifications are ensured for applications between ± 5 - and ± 15 -V power supplies. Some applications do not require equal positive and negative output voltage swing. Power supply voltages do not need to be equal. The OPA2277 can operate with as little as 5 V between the supplies and with up to 36 V between the supplies. For example, the positive supply could be set to 25 V with the negative supply at -5 V, or vice-versa. In addition, key parameters are ensured over the specified temperature range, -55°C to 125°C . The [Typical Characteristics](#) show parameters which vary significantly with operating voltage or temperature.

11 Layout

11.1 Layout Guidelines

Solder the lead-frame die pad to a thermal pad on the PCB. Mechanical drawings in [机械封装和可订购信息](#) show the physical dimensions for the package and pad.

Soldering the exposed pad significantly improves board-level reliability during temperature cycling, key push, package shear, and similar board-level tests. Even with applications that have low-power dissipation, the exposed pad must be soldered to the PCB to provide structural integrity and long-term reliability.

The OPA2277 has very-low offset voltage and drift. To achieve highest performance, optimize circuit layout and mechanical conditions. Offset voltage and drift can be degraded by small thermoelectric potentials at the operational amplifier inputs. Connections of dissimilar metals generate thermal potential which can degrade the ultimate performance of the OPA2277. These thermal potentials can be made to cancel by assuring that they are equal in both input terminals.

- Keep thermal mass of the connections made to the two input terminals similar.
- Locate heat sources as far as possible from the critical input circuitry.
- Shield operational amplifier and input circuitry from air currents such as cooling fans.

11.2 Layout Example

11.2.1 Board Layout

This demonstration fixture is a two-layer PCB. It uses a ground plane on the bottom, and signal and power traces on the top. The ground plane has been opened up around Op Amp pins sensitive to capacitive loading. Power-supply traces are laid out to keep current loop areas to a minimum. The SMA (or SMB) connectors may be mounted either vertically or horizontally.

The location and type of capacitors used for power-supply bypassing are crucial to high-frequency amplifiers. The tantalum capacitors, C_1 and C_2 , do not need to be as close to pins 7 and 4 on your PCB, and may be shared with other amplifiers.

11.2.2 Measurement Tips

This demonstration fixture and the component values shown are designed to operate in a 50Ω environment. Most data sheet plots are obtained in this manner. Change the component values for different input and output impedance levels.

Do not use high-impedance probes; they represent a heavy capacitive load to the Op Amps, and will alter the amplifier response. Instead, use low impedance ($\leq 500\Omega$) probes with adequate bandwidth. The probe input capacitance and resistance set an upper limit on the measurement bandwidth. If a high-impedance probe must be used, place a 100Ω resistor on the probe tip to isolate its capacitance from the circuit.

Layout Example (continued)

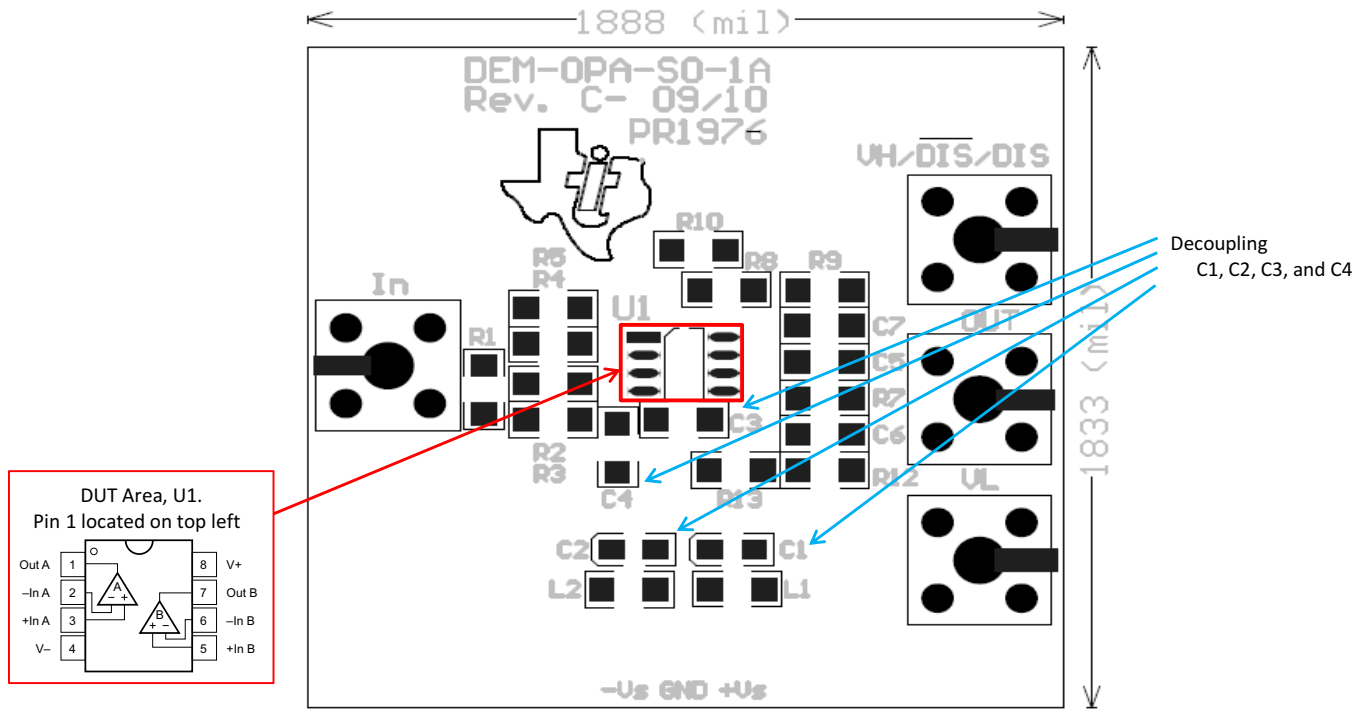

Figure 27. Decoupling Capacitors and DUT Area

12 器件和文档支持

12.1 商标

All trademarks are the property of their respective owners.

12.2 静电放电警告



这些装置包含有限的内置 ESD 保护。存储或装卸时，应将导线一起截短或将装置放置于导电泡棉中，以防止 MOS 门极遭受静电损伤。

12.3 术语表

[SLYZ022](#) — TI 术语表。

这份术语表列出并解释术语、首字母缩略词和定义。

13 机械封装和可订购信息

以下页中包括机械封装和可订购信息。 这些信息是针对指定器件可提供的最新数据。 这些数据会在无通知且不对本文档进行修订的情况下发生改变。 欲获得该数据表的浏览器版本，请查阅左侧的导航栏。

重要声明

德州仪器(TI)及其下属子公司有权根据 JESD46 最新标准,对所提供的产品和服务进行更正、修改、增强、改进或其它更改,并有权根据 JESD48 最新标准中止提供任何产品和服务。客户在下订单前应获取最新的相关信息,并验证这些信息是否完整且是最新的。所有产品的销售都遵循在订单确认时所提供的TI 销售条款与条件。

TI 保证其所销售的组件的性能符合产品销售时 TI 半导体产品销售条件与条款的适用规范。仅在 TI 保证的范围内,且 TI 认为有必要时才会使用测试或其它质量控制技术。除非适用法律做出了硬性规定,否则没有必要对每种组件的所有参数进行测试。

TI 对应用帮助或客户产品设计不承担任何义务。客户应对其使用 TI 组件的产品和应用自行负责。为尽量减小与客户产品和应用相关的风险,客户应提供充分的设计与操作安全措施。

TI 不对任何 TI 专利权、版权、屏蔽作品权或其它与使用了 TI 组件或服务的组合设备、机器或流程相关的 TI 知识产权中授予的直接或隐含权限作出任何保证或解释。TI 所发布的与第三方产品或服务有关的信息,不能构成从 TI 获得使用这些产品或服务的许可、授权、或认可。使用此类信息可能需要获得第三方的专利权或其它知识产权方面的许可,或是 TI 的专利权或其它知识产权方面的许可。

对于 TI 的产品手册或数据表中 TI 信息的重要部分,仅在没有对内容进行任何篡改且带有相关授权、条件、限制和声明的情况下才允许进行复制。TI 对此类篡改过的文件不承担任何责任或义务。复制第三方的信息可能需要服从额外的限制条件。

在转售 TI 组件或服务时,如果对该组件或服务参数的陈述与 TI 标明的参数相比存在差异或虚假成分,则会失去相关 TI 组件或服务的所有明示或暗示授权,且这是不正当的、欺诈性商业行为。TI 对任何此类虚假陈述均不承担任何责任或义务。

客户认可并同意,尽管任何应用相关信息或支持仍可能由 TI 提供,但他们将独立负责满足与其产品及其在应用中使用的 TI 产品相关的所有法律、法规和安全相关要求。客户声明并同意,他们具备制定与实施安全措施所需的全部专业技术和知识,可预见故障的危险后果、监测故障及其后果、降低有可能造成人身伤害的故障的发生机率并采取适当的补救措施。客户将全额赔偿因在此类安全关键应用中使用任何 TI 组件而对 TI 及其代理造成的任何损失。

在某些场合中,为了推进安全相关应用有可能对 TI 组件进行特别的促销。TI 的目标是利用此类组件帮助客户设计和创立其特有的可满足适用的功能安全性标准和要求的终端产品解决方案。尽管如此,此类组件仍然服从这些条款。

TI 组件未获得用于 FDA Class III (或类似的生命攸关医疗设备)的授权许可,除非各方授权官员已经达成了专门管控此类使用的特别协议。

只有那些 TI 特别注明属于军用等级或“增强型塑料”的 TI 组件才是设计或专门用于军事/航空应用或环境的。购买者认可并同意,对并非指定向军事或航空航天用途的 TI 组件进行军事或航空航天方面的应用,其风险由客户单独承担,并且由客户独立负责满足与此类使用相关的所有法律和法规要求。

TI 已明确指定符合 ISO/TS16949 要求的产品,这些产品主要用于汽车。在任何情况下,因使用非指定产品而无法达到 ISO/TS16949 要求, TI 不承担任何责任。

	产品		应用
数字音频	www.ti.com.cn/audio	通信与电信	www.ti.com.cn/telecom
放大器和线性器件	www.ti.com.cn/amplifiers	计算机及周边	www.ti.com.cn/computer
数据转换器	www.ti.com.cn/dataconverters	消费电子	www.ti.com.cn/consumer-apps
DLP® 产品	www.dlp.com	能源	www.ti.com.cn/energy
DSP - 数字信号处理器	www.ti.com.cn/dsp	工业应用	www.ti.com.cn/industrial
时钟和计时器	www.ti.com.cn/clockandtimers	医疗电子	www.ti.com.cn/medical
接口	www.ti.com.cn/interface	安防应用	www.ti.com.cn/security
逻辑	www.ti.com.cn/logic	汽车电子	www.ti.com.cn/automotive
电源管理	www.ti.com.cn/power	视频和影像	www.ti.com.cn/video
微控制器 (MCU)	www.ti.com.cn/microcontrollers		
RFID 系统	www.ti.com.cn/rfidsys		
OMAP应用处理器	www.ti.com/omap		
无线连通性	www.ti.com.cn/wirelessconnectivity	德州仪器在线技术支持社区	www.deyisupport.com

邮寄地址: 上海市浦东新区世纪大道1568号, 中建大厦32楼邮政编码: 200122
Copyright © 2014, 德州仪器半导体技术(上海)有限公司

PACKAGING INFORMATION

Orderable Device	Status (1)	Package Type	Package Drawing	Pins	Package Qty	Eco Plan (2)	Lead/Ball Finish (6)	MSL Peak Temp (3)	Op Temp (°C)	Device Marking (4/5)	Samples
OPA2277MDTEP	ACTIVE	SOIC	D	8	250	Green (RoHS & no Sb/Br)	CU NIPDAU	Level-3-260C-168 HR	-55 to 125	OPA 2277E	Samples
V62/14614-01XE	ACTIVE	SOIC	D	8	250	Green (RoHS & no Sb/Br)	CU NIPDAU	Level-3-260C-168 HR	-55 to 125	OPA 2277E	Samples

(1) The marketing status values are defined as follows:

ACTIVE: Product device recommended for new designs.

LIFEBUY: TI has announced that the device will be discontinued, and a lifetime-buy period is in effect.

NRND: Not recommended for new designs. Device is in production to support existing customers, but TI does not recommend using this part in a new design.

PREVIEW: Device has been announced but is not in production. Samples may or may not be available.

OBSOLETE: TI has discontinued the production of the device.

(2) Eco Plan - The planned eco-friendly classification: Pb-Free (RoHS), Pb-Free (RoHS Exempt), or Green (RoHS & no Sb/Br) - please check <http://www.ti.com/productcontent> for the latest availability information and additional product content details.

TBD: The Pb-Free/Green conversion plan has not been defined.

Pb-Free (RoHS): TI's terms "Lead-Free" or "Pb-Free" mean semiconductor products that are compatible with the current RoHS requirements for all 6 substances, including the requirement that lead not exceed 0.1% by weight in homogeneous materials. Where designed to be soldered at high temperatures, TI Pb-Free products are suitable for use in specified lead-free processes.

Pb-Free (RoHS Exempt): This component has a RoHS exemption for either 1) lead-based flip-chip solder bumps used between the die and package, or 2) lead-based die adhesive used between the die and leadframe. The component is otherwise considered Pb-Free (RoHS compatible) as defined above.

Green (RoHS & no Sb/Br): TI defines "Green" to mean Pb-Free (RoHS compatible), and free of Bromine (Br) and Antimony (Sb) based flame retardants (Br or Sb do not exceed 0.1% by weight in homogeneous material)

(3) MSL, Peak Temp. - The Moisture Sensitivity Level rating according to the JEDEC industry standard classifications, and peak solder temperature.

(4) There may be additional marking, which relates to the logo, the lot trace code information, or the environmental category on the device.

(5) Multiple Device Markings will be inside parentheses. Only one Device Marking contained in parentheses and separated by a "~" will appear on a device. If a line is indented then it is a continuation of the previous line and the two combined represent the entire Device Marking for that device.

(6) Lead/Ball Finish - Orderable Devices may have multiple material finish options. Finish options are separated by a vertical ruled line. Lead/Ball Finish values may wrap to two lines if the finish value exceeds the maximum column width.

Important Information and Disclaimer: The information provided on this page represents TI's knowledge and belief as of the date that it is provided. TI bases its knowledge and belief on information provided by third parties, and makes no representation or warranty as to the accuracy of such information. Efforts are underway to better integrate information from third parties. TI has taken and continues to take reasonable steps to provide representative and accurate information but may not have conducted destructive testing or chemical analysis on incoming materials and chemicals. TI and TI suppliers consider certain information to be proprietary, and thus CAS numbers and other limited information may not be available for release.

In no event shall TI's liability arising out of such information exceed the total purchase price of the TI part(s) at issue in this document sold by TI to Customer on an annual basis.

OTHER QUALIFIED VERSIONS OF OPA2277-EP :

- Catalog: [OPA2277](#)

NOTE: Qualified Version Definitions:

- Catalog - TI's standard catalog product



D0008A

PACKAGE OUTLINE

SOIC - 1.75 mm max height

SMALL OUTLINE INTEGRATED CIRCUIT



4214825/C 02/2019

NOTES:

1. Linear dimensions are in inches [millimeters]. Dimensions in parenthesis are for reference only. Controlling dimensions are in inches. Dimensioning and tolerancing per ASME Y14.5M.
2. This drawing is subject to change without notice.
3. This dimension does not include mold flash, protrusions, or gate burrs. Mold flash, protrusions, or gate burrs shall not exceed $.006$ [0.15] per side.
4. This dimension does not include interlead flash.
5. Reference JEDEC registration MS-012, variation AA.

EXAMPLE BOARD LAYOUT

D0008A

SOIC - 1.75 mm max height

SMALL OUTLINE INTEGRATED CIRCUIT



LAND PATTERN EXAMPLE
 EXPOSED METAL SHOWN
 SCALE:8X



SOLDER MASK DETAILS

4214825/C 02/2019

NOTES: (continued)

- 6. Publication IPC-7351 may have alternate designs.
- 7. Solder mask tolerances between and around signal pads can vary based on board fabrication site.

EXAMPLE STENCIL DESIGN

D0008A

SOIC - 1.75 mm max height

SMALL OUTLINE INTEGRATED CIRCUIT



SOLDER PASTE EXAMPLE
BASED ON .005 INCH [0.125 MM] THICK STENCIL
SCALE:8X

4214825/C 02/2019

NOTES: (continued)

8. Laser cutting apertures with trapezoidal walls and rounded corners may offer better paste release. IPC-7525 may have alternate design recommendations.
9. Board assembly site may have different recommendations for stencil design.

重要声明和免责声明

TI 均以“原样”提供技术性数据（包括数据表）、设计资源（包括参考设计）、应用或其他设计建议、网络工具、安全信息和其他资源，不保证其中不含任何瑕疵，且不做任何明示或暗示的担保，包括但不限于对适销性、适合某特定用途或不侵犯任何第三方知识产权的暗示担保。

所述资源可供专业开发人员应用TI 产品进行设计使用。您将对以下行为独自承担全部责任：(1) 针对您的应用选择合适的TI 产品；(2) 设计、验证并测试您的应用；(3) 确保您的应用满足相应标准以及任何其他安全、安保或其他要求。所述资源如有变更，恕不另行通知。TI 对您使用所述资源的授权仅限于开发资源所涉及TI 产品的相关应用。除此之外不得复制或展示所述资源，也不提供其它TI 或任何第三方的知识产权授权许可。如因使用所述资源而产生任何索赔、赔偿、成本、损失及债务等，TI 对此概不负责，并且您须赔偿由此对TI 及其代表造成的损害。

TI 所提供产品均受TI 的销售条款 (<http://www.ti.com.cn/zh-cn/legal/termsofsale.html>) 以及ti.com.cn上或随附TI产品提供的其他可适用条款的约束。TI提供所述资源并不扩展或以其他方式更改TI 针对TI 产品所发布的可适用的担保范围或担保免责声明。

邮寄地址：上海市浦东新区世纪大道 1568 号中建大厦 32 楼，邮政编码：200122
Copyright © 2019 德州仪器半导体技术（上海）有限公司