

LM193JAN Low Power Low Offset Voltage Dual Comparators

Check for Samples: [LM193JAN](#)

FEATURES

- **Wide Supply**
 - Voltage Range: $5.0V_{DC}$ to $36V_{DC}$
 - Single or Dual Supplies: $\pm 2.5V_{DC}$ to $\pm 18V_{DC}$
- **Very Low Supply Current Drain (0.4 mA) — Independent of Supply Voltage**
- **Low Input Biasing Current: 25 nA typ**
- **Low Input Offset Current: ± 3 nA typ**
- **Maximum Offset Voltage +5mV Max @ 25°C**
- **Input Common-Mode Voltage Range Includes Ground**
- **Differential Input Voltage Range Equal to the Power Supply Voltage**
- **Low Output Saturation Voltage, : 250 mV at 4 mA typ**
- **Output Voltage Compatible with TTL, DTL, ECL, MOS and CMOS Logic Systems**

ADVANTAGES

- **High Precision Comparators**
- **Reduced V_{OS} Drift Over Temperature**
- **Eliminates Need for Dual Supplies**
- **Allows Sensing Near Ground**
- **Compatible with all Forms of Logic**
- **Power Drain Suitable for Battery Operation**
Squarewave Oscillator

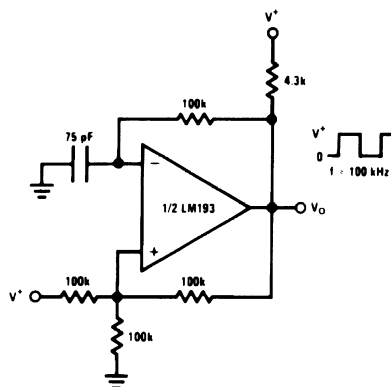

DESCRIPTION

The LM193 series consists of two independent precision voltage comparators with an offset voltage specification as low as 2.0 mV max for two comparators which were designed specifically to operate from a single power supply over a wide range of voltages. Operation from split power supplies is also possible and the low power supply current drain is independent of the magnitude of the power supply voltage. These comparators also have a unique characteristic in that the input common-mode voltage range includes ground, even though operated from a single power supply voltage.

Application areas include limit comparators, simple analog to digital converters; pulse, squarewave and time delay generators; wide range VCO; MOS clock timers; multivibrators and high voltage digital logic gates. The LM193 series was designed to directly interface with TTL and CMOS. When operated from both plus and minus power supplies, the LM193 series will directly interface with MOS logic where their low power drain is a distinct advantage over standard comparators.

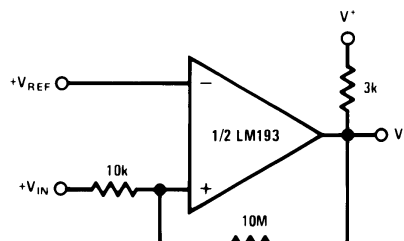
Non-Inverting Comparator with Hysteresis

Please be aware that an important notice concerning availability, standard warranty, and use in critical applications of Texas Instruments semiconductor products and disclaimers thereto appears at the end of this data sheet.

All trademarks are the property of their respective owners.

Schematic and Connection Diagrams

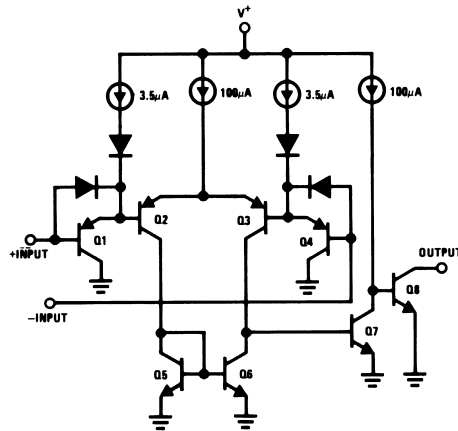

Figure 1. TO-99

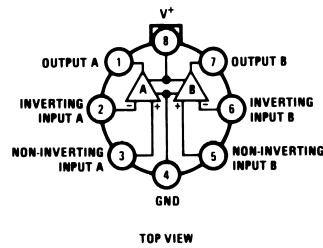
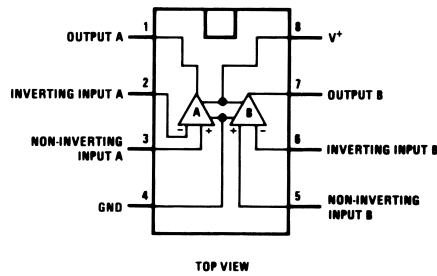

Figure 2. CDIP Package



These devices have limited built-in ESD protection. The leads should be shorted together or the device placed in conductive foam during storage or handling to prevent electrostatic damage to the MOS gates.

Absolute Maximum Ratings⁽¹⁾

Supply Voltage, V ⁺		36V _{DC} or ±18V _{DC}		
Differential Input Voltage ⁽²⁾		36V		
Output Voltage		36V		
Input Voltage		-0.3V _{DC} to +36V _{DC}		
Input Current (V _{IN} < -0.3V _{DC}) ⁽³⁾		50 mA		
Power Dissipation ⁽⁴⁾		CDIP	400 mW @ T _A = 125°C	
		TO-99	330 mW @ T _A = 125°C	
Maximum Junction Temperature (T _{Jmax})		175°C		
Output Short-Circuit to Ground ⁽⁵⁾		Continuous		
Operating Temperature Range		-55°C ≤ T _A ≤ +125°C		
Storage Temperature Range		-65°C ≤ T _A ≤ +150°C		
Thermal Resistance	θ _{JA}	TO-99	Metal Can (Still Air)	174°C/W
			Metal Can (500LF/Min Air flow)	99°C/W
		CDIP	CERDIP (Still Air)	146°C/W
			CERDIP (500LF/Min Air flow)	85°C/W
	θ _{JC}	TO-99	44°C/W	
		CDIP	33°C/W	
Lead Temperature(Soldering, 10 seconds)		260°C		
ESD Tolerance ⁽⁶⁾		500V		

- (1) Absolute Maximum Ratings indicate limits beyond which damage to the device may occur. Operating Ratings indicate conditions for which the device is functional, but do not ensure specific performance limits. For ensured specifications and test conditions, see the Electrical Characteristics. The ensured specifications apply only for the test conditions listed. Some performance characteristics may degrade when the device is not operated under the listed test conditions.
- (2) Positive excursions of input voltage may exceed the power supply level. As long as the other voltage remains within the common-mode range, the comparator will provide a proper output state. The low input voltage state must not be less than -0.3V (or 0.3V below the magnitude of the negative power supply, if used).
- (3) This input current will only exist when the voltage at any of the input leads is driven negative. It is due to the collector-base junction of the input PNP transistors becoming forward biased and thereby acting as input diode clamps. In addition to this diode action, there is also lateral NPN parasitic transistor action on the IC chip. This transistor action can cause the output voltages of the comparators to go to the V⁺ voltage level (or to ground for a large overdrive) for the time duration that an input is driven negative. This is not destructive and normal output states will re-establish when the input voltage, which was negative, again returns to a value greater than -0.3V_{DC}.
- (4) The maximum power dissipation must be derated at elevated temperatures and is dictated by T_{Jmax} (maximum junction temperature), θ_{JA} (package junction to ambient thermal resistance), and T_A (ambient temperature). The maximum allowable power dissipation at any temperature is P_{Dmax} = (T_{Jmax} - T_A)/θ_{JA} or the number given in the Absolute Maximum Ratings, whichever is lower.
- (5) Short circuits from the output to V⁺ can cause excessive heating and eventual destruction. When considering short circuits to ground, the maximum output current is approximately 20 mA independent of the magnitude of V⁺.
- (6) Human body model, 1.5KΩ in series with 100pF.

Quality Conformance Inspection

Mil-Std-883, Method 5005 - Group A

Subgroup	Description	Temp°C
1	Static tests at	25
2	Static tests at	125
3	Static tests at	-55
4	Dynamic tests at	25
5	Dynamic tests at	125
6	Dynamic tests at	-55
7	Functional tests at	25
8A	Functional tests at	125
8B	Functional tests at	-55
9	Switching tests at	25
10	Switching tests at	125
11	Switching tests at	-55
12	Settling time at	25
13	Settling time at	125
14	Settling time at	-55

LM193JAN Electrical Characteristics DC Parameters

Symbol	Parameter	Conditions	Notes	Min	Max	Unit	Sub-groups
V_{IO}	Input Offset Voltage	$+V_{CC} = 30V, -V_{CC} = 0V,$ $V_O = 15V$		-5.0	5.0	mV	1
				-7.0	7.0	mV	2, 3
		$+V_{CC} = 2V, -V_{CC} = -28V,$ $V_O = -13V$		-5.0	5.0	mV	1
				-7.0	7.0	mV	2, 3
		$+V_{CC} = 5V, -V_{CC} = 0V,$ $V_O = 1.4V$		-5.0	5.0	mV	1
				-7.0	7.0	mV	2, 3
		$+V_{CC} = 2V, -V_{CC} = -3V,$ $V_O = -1.6V$		-5.0	5.0	mV	1
				-7.0	7.0	mV	2, 3
I_{IO}	Input offset Current	$+V_{CC} = 30V, -V_{CC} = 0V,$ $V_O = 15V, R_S = 20K\Omega$	See ⁽¹⁾	-25	25	nA	1, 2
			See ⁽¹⁾	-75	75	nA	3
		$+V_{CC} = 2V, -V_{CC} = -28V,$ $V_O = -13V, R_S = 20K\Omega$	See ⁽¹⁾	-25	25	nA	1, 2
			See ⁽¹⁾	-75	75	nA	3
		$+V_{CC} = 5V, -V_{CC} = 0V,$ $V_O = 1.4V, R_S = 20K\Omega$	See ⁽¹⁾	-25	25	nA	1, 2
			See ⁽¹⁾	-75	75	nA	3
		$+V_{CC} = 2V, -V_{CC} = -3V,$ $V_O = -1.6V, R_S = 20K\Omega$	See ⁽¹⁾	-25	25	nA	1, 2
			See ⁽¹⁾	-75	75	nA	3
$\pm I_{IB}$	Input Bias Current	$+V_{CC} = 30V, -V_{CC} = 0V,$ $V_O = 15V, R_S = 20K\Omega$	See ⁽¹⁾	-100	+0.1	nA	1, 2
			See ⁽¹⁾	-200	+0.1	nA	3
		$+V_{CC} = 2V, -V_{CC} = -28V,$ $V_O = -13V, R_S = 20K\Omega$	See ⁽¹⁾	-100	+0.1	nA	1, 2
			See ⁽¹⁾	-200	+0.1	nA	3
		$+V_{CC} = 5V, -V_{CC} = 0V,$ $V_O = 1.4V, R_S = 20K\Omega$	See ⁽¹⁾	-100	+0.1	nA	1, 2
			See ⁽¹⁾	-200	+0.1	nA	3
		$+V_{CC} = 2V, -V_{CC} = -3V,$ $V_O = -1.6V, R_S = 20K\Omega$	See ⁽¹⁾	-100	+0.1	nA	1, 2
			See ⁽¹⁾	-200	+0.1	nA	3

(1) S/S $R_S = 20K\Omega$, tested with $R_S = 100K\Omega$ for better resolution

**LM193JAN Electrical Characteristics
DC Parameters (continued)**

Symbol	Parameter	Conditions	Notes	Min	Max	Unit	Sub-groups
CMRR	Input Voltage Common Mode Rejection	$2V \leq +V_{CC} \leq 30V$, $-28V \leq -V_{CC} \leq 0V$, $-13V \leq V_O \leq 15V$		76		dB	1, 2, 3
		$2V \leq +V_{CC} \leq 5V$, $-3V \leq -V_{CC} \leq 0V$, $-1.6V \leq V_O \leq 1.4V$		70		dB	1, 2, 3
I_{CEX}	Output Leakage Current	$+V_{CC} = 30V$, $-V_{CC} = 0V$, $V_O = +30V$			1.0	μA	1, 2, 3
$+I_{IL}$	Input Leakage Current	$+V_{CC} = 36V$, $-V_{CC} = 0V$, $+V_I = 34V$, $-V_I = 0V$		-500	500	nA	1, 2, 3
$-I_{IL}$	Input Leakage Current	$+V_{CC} = 36V$, $-V_{CC} = 0V$, $+V_I = 0V$, $-V_I = 34V$		-500	500	nA	1, 2, 3
V_{OL}	Logical "0" Output Voltage	$+V_{CC} = 4.5V$, $-V_{CC} = 0V$, $I_O = 4mA$			0.4	V	1
					0.7	V	2, 3
		$+V_{CC} = 4.5V$, $-V_{CC} = 0V$, $I_O = 8mA$			1.5	V	1
					2.0	V	2, 3
I_{CC}	Power Supply Current	$+V_{CC} = 5V$, $-V_{CC} = 0V$, $V_{ID} = 15mV$			2.0	mA	1, 2
					3.0	mA	3
		$+V_{CC} = 30V$, $-V_{CC} = 0V$, $V_{ID} = 15mV$			3.0	mA	1, 2
					4.0	mA	3
$\Delta I_O / \Delta T$	Temperature Coefficient of Input Offset Voltage	$25^\circ C \leq T_A \leq +125^\circ C$	See ⁽²⁾	-25	25	$\mu V/^\circ C$	2
		$-55^\circ C \leq T_A \leq 25^\circ C$	See ⁽²⁾	-25	25	$\mu V/^\circ C$	3
$\Delta I_{IO} / \Delta T$	Temperature Coefficient of Input Offset Current	$25^\circ C \leq T_A \leq +125^\circ C$	See ⁽²⁾	-300	300	$pA/^\circ C$	2
		$-55^\circ C \leq T_A \leq 25^\circ C$	See ⁽²⁾	-400	400	$pA/^\circ C$	3
A_{VS}	Open Loop Voltage Gain	$+V_{CC} = 15V$, $-V_{CC} = 0V$, $R_L = 15K\Omega$, $1V \leq V_O \leq 11V$	See ⁽³⁾	50		V/mV	4
			See ⁽³⁾	25		V/mV	5, 6
V_{Lat}	Voltage Latch (Logical "1" Input)	$+V_{CC} = 5V$, $-V_{CC} = 0V$, $V_I = 10V$, $I_O = 4mA$			0.4	V	9

(2) Calculated parameter for $\Delta V_{IO} / \Delta T$ and $\Delta I_{IO} / \Delta T$.

(3) K in datalog is equivalent to V/mV.

AC Parameters

The following conditions apply, unless otherwise specified. $+V_{CC} = 5V$, $-V_{CC} = 0V$

Symbol	Parameter	Conditions	Notes	Min	Max	Unit	Sub-groups
t_{RLH}	Response Time	$V_I = 100mV$, $R_L = 5.1K\Omega$, $V_{OD} = 5mV$			5.0	μS	7, 8B
					7.0	μS	8A
		$V_I = 100mV$, $R_L = 5.1K\Omega$, $V_{OD} = 50mV$			0.8	μS	7, 8B
t_{RHL}	Response Time	$V_I = 100mV$, $R_L = 5.1K\Omega$, $V_{OD} = 5mV$			2.5	μS	7, 8B
					3.0	μS	8A
		$V_I = 100mV$, $R_L = 5.1K\Omega$, $V_{OD} = 50mV$			0.8	μS	7, 8B
CS	Channel Separation	$+V_{CC} = 20V$, $-V_{CC} = -10V$, A to B		80		dB	7
		$+V_{CC} = 20V$, $-V_{CC} = -10V$, B to A		80		dB	7

Typical Performance Characteristics

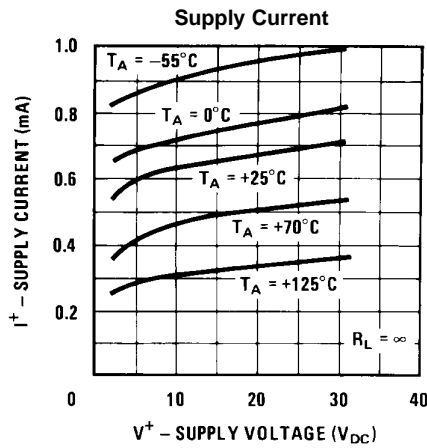

Figure 3.

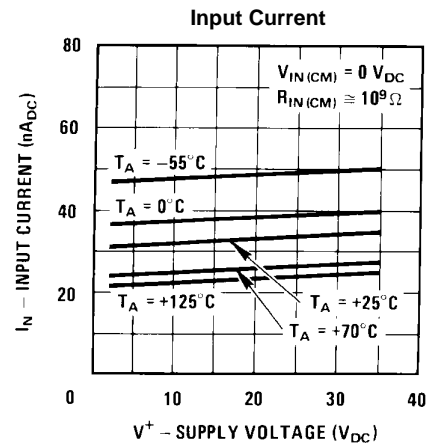

Figure 4.

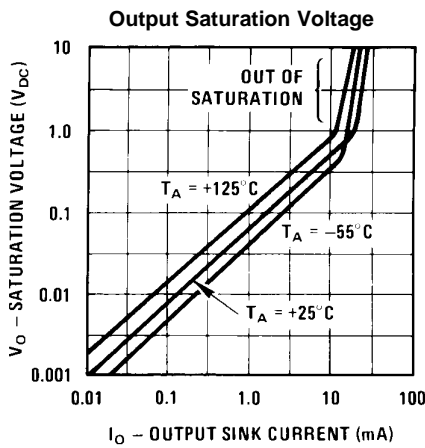

Figure 5.

Response Time for Various Input Overdrives—Negative Transition

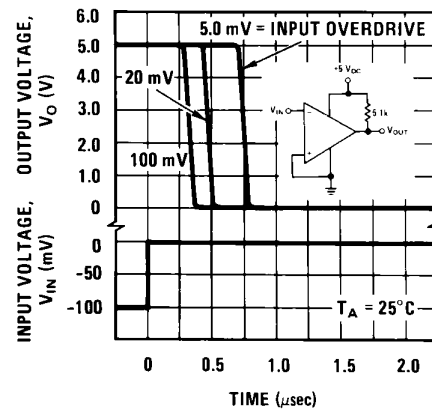

Figure 6.

Response Time for Various Input Overdrives—Positive Transition

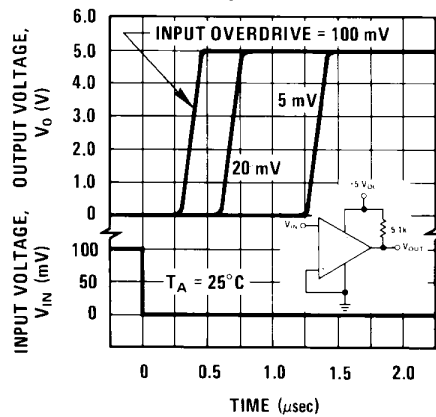

Figure 7.

APPLICATION HINTS

The LM193 series are high gain, wide bandwidth devices which, like most comparators, can easily oscillate if the output lead is inadvertently allowed to capacitively couple to the inputs via stray capacitance. This shows up only during the output voltage transition intervals as the comparator change states. Power supply bypassing is not required to solve this problem. Standard PC board layout is helpful as it reduces stray input-output coupling. Reducing the input resistors to $< 10\text{ k}\Omega$ reduces the feedback signal levels and finally, adding even a small amount (1.0 to 10 mV) of positive feedback (hysteresis) causes such a rapid transition that oscillations due to stray feedback are not possible. Simply socketing the IC and attaching resistors to the pins will cause input-output oscillations during the small transition intervals unless hysteresis is used. If the input signal is a pulse waveform, with relatively fast rise and fall times, hysteresis is not required.

All input pins of any unused comparators should be tied to the negative supply.

The bias network of the LM193 series establishes a drain current which is independent of the magnitude of the power supply voltage over the range of from 2.0 V_{DC} to 30 V_{DC} .

It is usually unnecessary to use a bypass capacitor across the power supply line.

The differential input voltage may be larger than V^+ without damaging the device ⁽¹⁾. Protection should be provided to prevent the input voltages from going negative more than $-0.3\text{ V}_{\text{DC}}$ (at 25°C). An input clamp diode can be used as shown in the applications section.

The output of the LM193 series is the uncommitted collector of a grounded-emitter NPN output transistor. Many collectors can be tied together to provide an output OR'ing function. An output pull-up resistor can be connected to any available power supply voltage within the permitted supply voltage range and there is no restriction on this voltage due to the magnitude of the voltage which is applied to the V^+ terminal of the LM193 package. The output can also be used as a simple SPST switch to ground (when a pull-up resistor is not used). The amount of current which the output device can sink is limited by the drive available (which is independent of V^+) and the β of this device. When the maximum current limit is reached (approximately 16mA), the output transistor will come out of saturation and the output voltage will rise very rapidly. The output saturation voltage is limited by the approximately $60\Omega\text{ }r_{\text{SAT}}$ of the output transistor. The low offset voltage of the output transistor (1.0mV) allows the output to clamp essentially to ground level for small load currents.

(1) Positive excursions of input voltage may exceed the power supply level. As long as the other voltage remains within the common-mode range, the comparator will provide a proper output state. The low input voltage state must not be less than -0.3V (or 0.3V below the magnitude of the negative power supply, if used).

Typical Applications

($V^+ = 5.0 V_{DC}$)

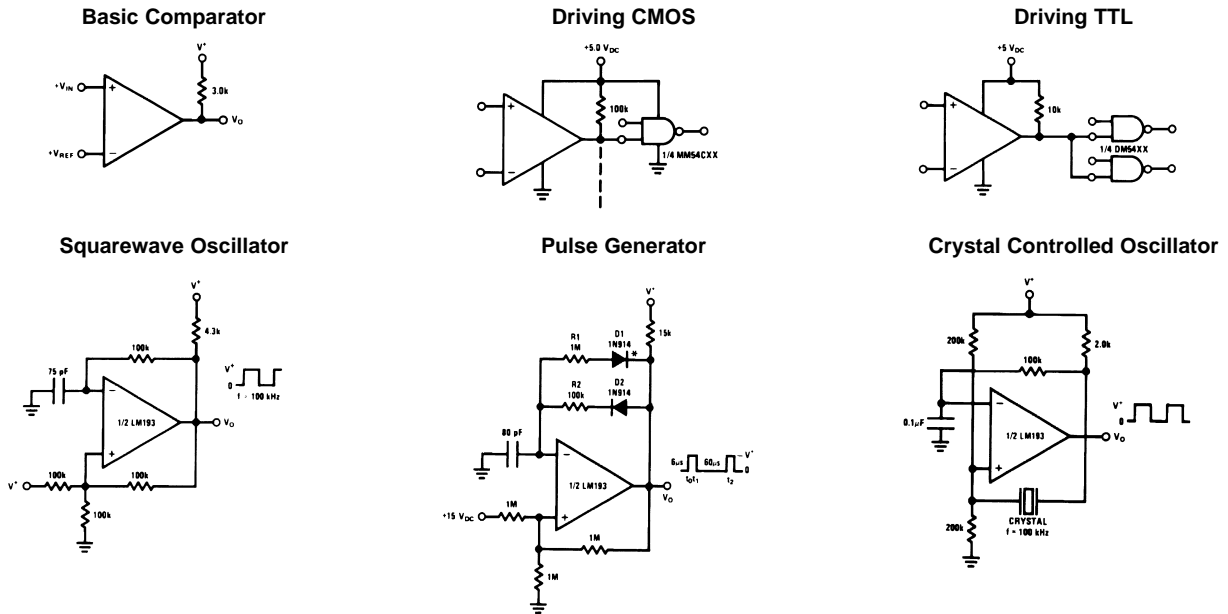

* For large ratios of $R1/R2$, $D1$ can be omitted.

Figure 8. Two-Decade High Frequency VCO

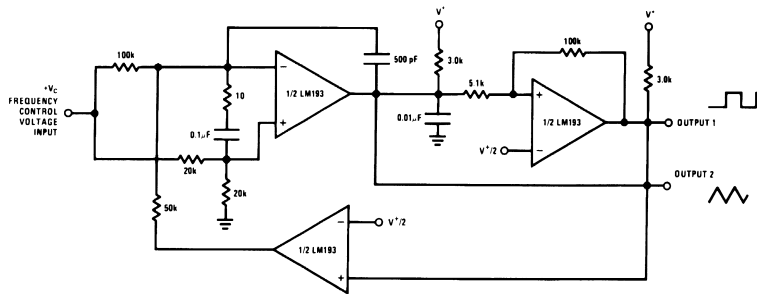

$V^+ = +30 V_{DC}$
 $+250 mV_{DC} \leq V_C \leq +50 V_{DC}$
 $700Hz \leq f_o \leq 100kHz$

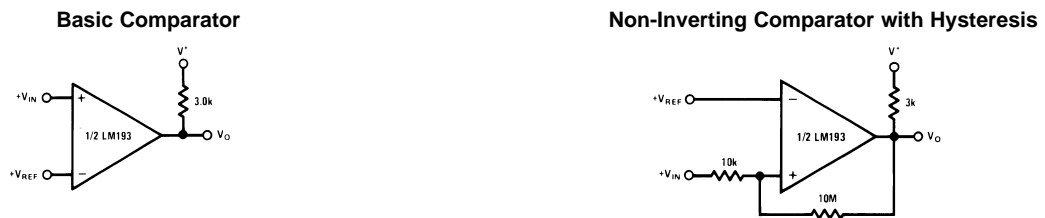

Inverting Comparator with Hysteresis

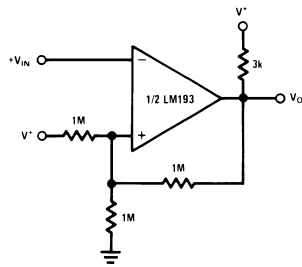

Output Strobing

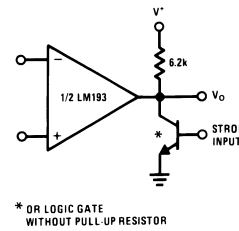

AND Gate

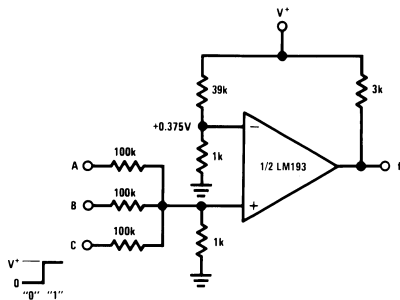

OR Gate

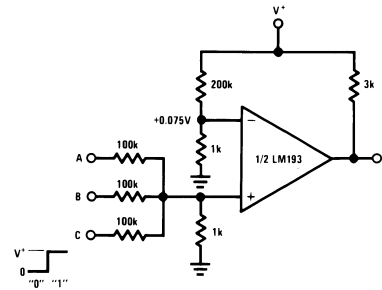

Large Fan-in AND Gate

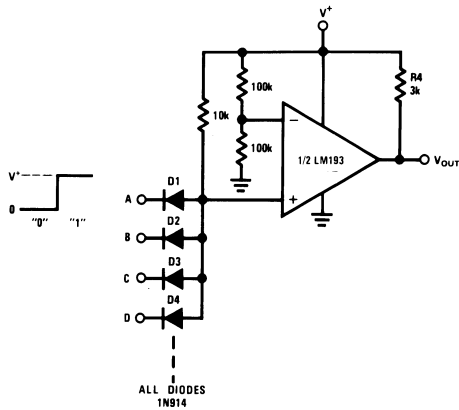

Limit Comparator

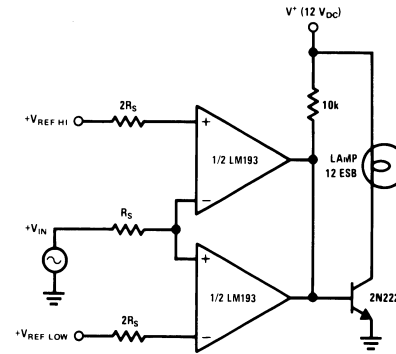

Comparing Input Voltages of Opposite Polarity

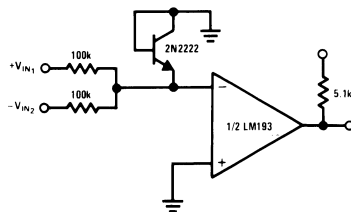

ORing the Outputs

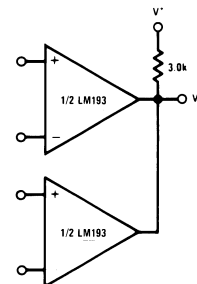

Zero Crossing Detector (Single Power Supply)

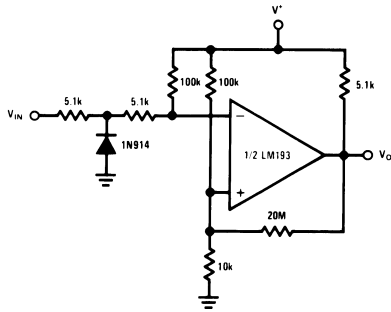

One-Shot Multivibrator

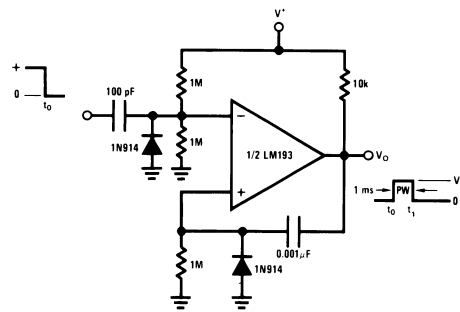

Bi-Stable Multivibrator

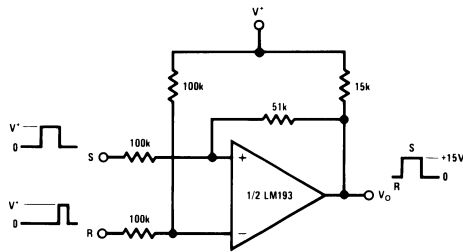

One-Shot Multivibrator with Input Lock Out

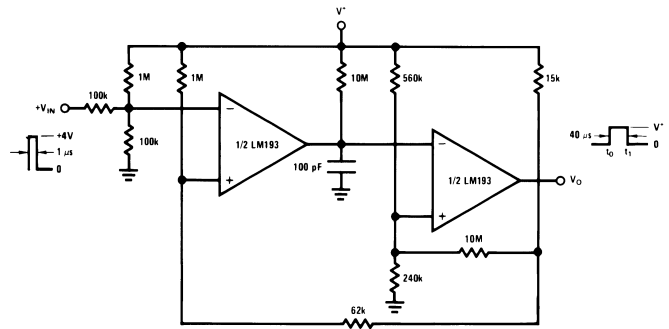

Zero Crossing Detector

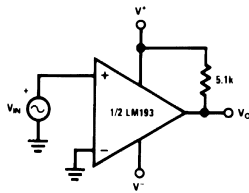

Comparator With a Negative Reference

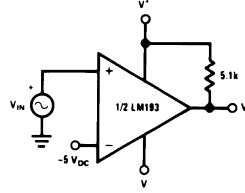
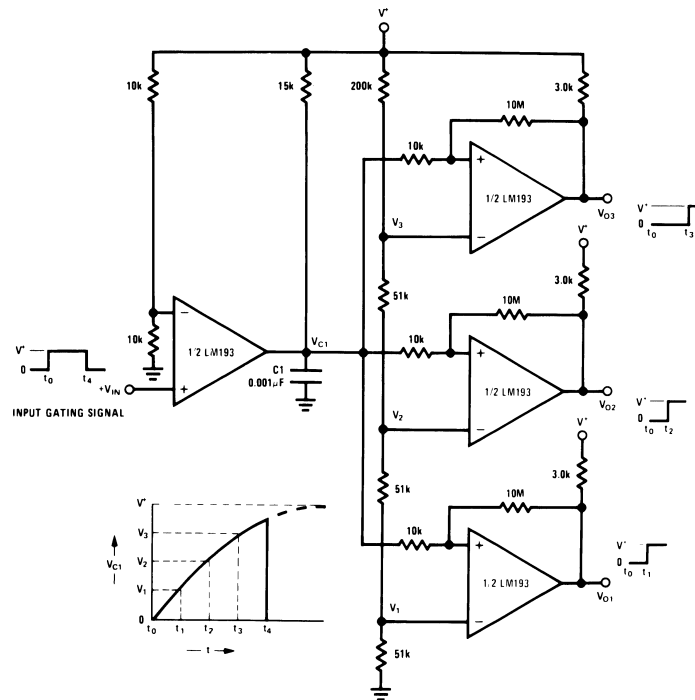

Figure 9. Time Delay Generator



Split-Supply Applications

($V^+ = +15 V_{DC}$ and $V^- = -15 V_{DC}$)

Figure 10. MOS Clock Driver

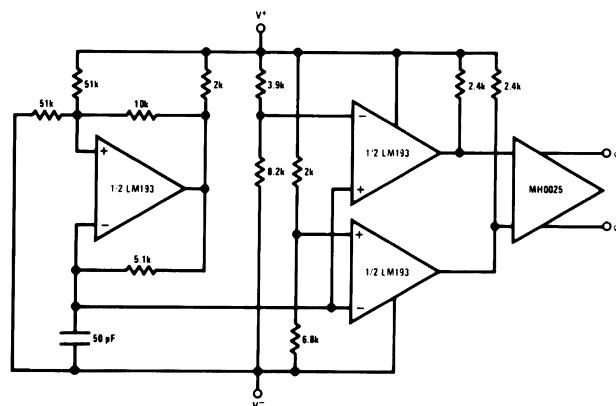

REVISION HISTORY SECTION

Date Released	Revision	Section	Originator	Changes
05/09/05	A	New Release. Corporate format	L. Lytle	1 MDS datasheets converted into one Corp. datasheet format. DC Drift table was deleted due to no JANS product offerings. MJLM193-X Rev 1A1 MDS will be archived.
03/26/2013	A	All Sections		Changed layout of National Data Sheet to TI format

PACKAGING INFORMATION

Orderable Device	Status (1)	Package Type	Package Drawing	Pins	Package Qty	Eco Plan (2)	Lead/Ball Finish (6)	MSL Peak Temp (3)	Op Temp (°C)	Device Marking (4/5)	Samples
JL193BGA	ACTIVE	TO-99	LMC	8	20	TBD	Call TI	Call TI	-55 to 125	JL193BGA JM38510/11202BGA Q ACO JM38510/11202BGA Q >T	Samples
JM38510/11202BGA	ACTIVE	TO-99	LMC	8	20	TBD	Call TI	Call TI	-55 to 125	JL193BGA JM38510/11202BGA Q ACO JM38510/11202BGA Q >T	Samples
M38510/11202BGA	ACTIVE	TO-99	LMC	8	20	TBD	Call TI	Call TI	-55 to 125	JL193BGA JM38510/11202BGA Q ACO JM38510/11202BGA Q >T	Samples

(1) The marketing status values are defined as follows:

ACTIVE: Product device recommended for new designs.

LIFEBUY: TI has announced that the device will be discontinued, and a lifetime-buy period is in effect.

NRND: Not recommended for new designs. Device is in production to support existing customers, but TI does not recommend using this part in a new design.

PREVIEW: Device has been announced but is not in production. Samples may or may not be available.

OBSOLETE: TI has discontinued the production of the device.

(2) **RoHS:** TI defines "RoHS" to mean semiconductor products that are compliant with the current EU RoHS requirements for all 10 RoHS substances, including the requirement that RoHS substance do not exceed 0.1% by weight in homogeneous materials. Where designed to be soldered at high temperatures, "RoHS" products are suitable for use in specified lead-free processes. TI may reference these types of products as "Pb-Free".

RoHS Exempt: TI defines "RoHS Exempt" to mean products that contain lead but are compliant with EU RoHS pursuant to a specific EU RoHS exemption.

Green: TI defines "Green" to mean the content of Chlorine (Cl) and Bromine (Br) based flame retardants meet JS709B low halogen requirements of <=1000ppm threshold. Antimony trioxide based flame retardants must also meet the <=1000ppm threshold requirement.

(3) MSL, Peak Temp. - The Moisture Sensitivity Level rating according to the JEDEC industry standard classifications, and peak solder temperature.

(4) There may be additional marking, which relates to the logo, the lot trace code information, or the environmental category on the device.

(5) Multiple Device Markings will be inside parentheses. Only one Device Marking contained in parentheses and separated by a "~" will appear on a device. If a line is indented then it is a continuation of the previous line and the two combined represent the entire Device Marking for that device.

⁽⁶⁾ Lead/Ball Finish - Orderable Devices may have multiple material finish options. Finish options are separated by a vertical ruled line. Lead/Ball Finish values may wrap to two lines if the finish value exceeds the maximum column width.

Important Information and Disclaimer: The information provided on this page represents TI's knowledge and belief as of the date that it is provided. TI bases its knowledge and belief on information provided by third parties, and makes no representation or warranty as to the accuracy of such information. Efforts are underway to better integrate information from third parties. TI has taken and continues to take reasonable steps to provide representative and accurate information but may not have conducted destructive testing or chemical analysis on incoming materials and chemicals. TI and TI suppliers consider certain information to be proprietary, and thus CAS numbers and other limited information may not be available for release.

In no event shall TI's liability arising out of such information exceed the total purchase price of the TI part(s) at issue in this document sold by TI to Customer on an annual basis.

LMC (O-MBCY-W8)

METAL CYLINDRICAL PACKAGE

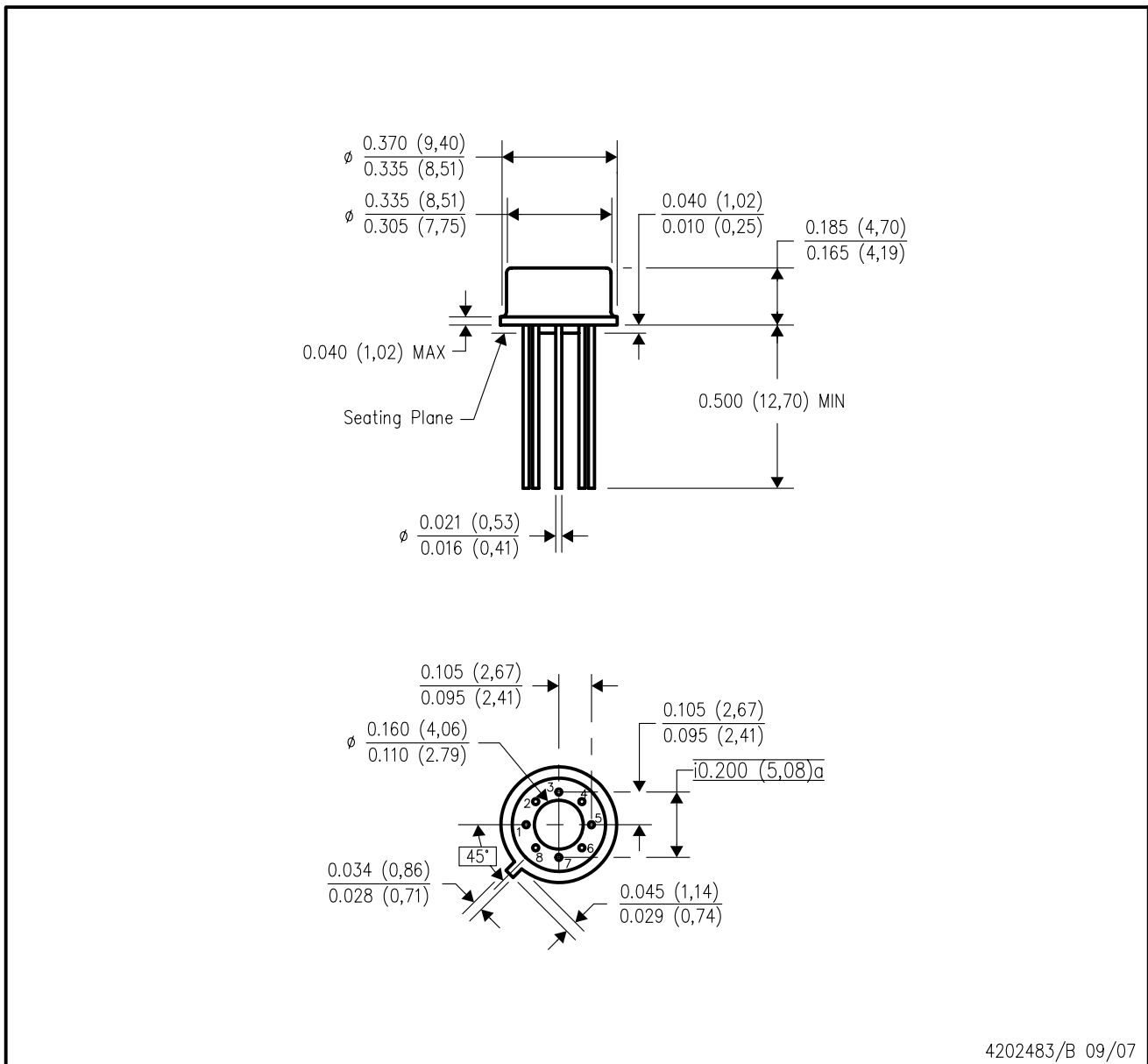

- NOTES:
- A. All linear dimensions are in inches (millimeters).
 - B. This drawing is subject to change without notice.
 - C. Leads in true position within 0.010 (0,25) R @ MMC at seating plane.
 - D. Pin numbers shown for reference only. Numbers may not be marked on package.
 - E. Falls within JEDEC MO-002/T0-99.

IMPORTANT NOTICE AND DISCLAIMER

TI PROVIDES TECHNICAL AND RELIABILITY DATA (INCLUDING DATASHEETS), DESIGN RESOURCES (INCLUDING REFERENCE DESIGNS), APPLICATION OR OTHER DESIGN ADVICE, WEB TOOLS, SAFETY INFORMATION, AND OTHER RESOURCES "AS IS" AND WITH ALL FAULTS, AND DISCLAIMS ALL WARRANTIES, EXPRESS AND IMPLIED, INCLUDING WITHOUT LIMITATION ANY IMPLIED WARRANTIES OF MERCHANTABILITY, FITNESS FOR A PARTICULAR PURPOSE OR NON-INFRINGEMENT OF THIRD PARTY INTELLECTUAL PROPERTY RIGHTS.

These resources are intended for skilled developers designing with TI products. You are solely responsible for (1) selecting the appropriate TI products for your application, (2) designing, validating and testing your application, and (3) ensuring your application meets applicable standards, and any other safety, security, or other requirements. These resources are subject to change without notice. TI grants you permission to use these resources only for development of an application that uses the TI products described in the resource. Other reproduction and display of these resources is prohibited. No license is granted to any other TI intellectual property right or to any third party intellectual property right. TI disclaims responsibility for, and you will fully indemnify TI and its representatives against, any claims, damages, costs, losses, and liabilities arising out of your use of these resources.

TI's products are provided subject to TI's Terms of Sale (www.ti.com/legal/termsofsale.html) or other applicable terms available either on ti.com or provided in conjunction with such TI products. TI's provision of these resources does not expand or otherwise alter TI's applicable warranties or warranty disclaimers for TI products.

Mailing Address: Texas Instruments, Post Office Box 655303, Dallas, Texas 75265
Copyright © 2019, Texas Instruments Incorporated