

## INA260

### 具有低漂移、高精度集成分流器的精密电流和功率监测计

#### 1 特性

- 集成精密分流电阻：
  - 电流感测电阻：2mΩ
  - 等效容差为 0.1%
  - 15A 持续电流（-40°C 至 +85°C）
  - 10ppm/°C 温度系数（0°C 至 +125°C）
- 感测的总线电压范围：0V 至 36V
- 高侧或低侧感测
- 报告电流、电压和功率
- 高精度：
  - ±0.15% 系统增益误差（最大值）
  - 5mA 偏移（最大值）
- 可配置的取平均值选项
- 16 个可编程地址
- 由 2.7V 至 5.5V 电源供电
- 16 引脚薄型小尺寸 (TSSOP) 封装

#### 2 应用

- 测试设备
- 服务器
- 电信设备
- 计算
- 电源管理
- 电池充电器
- 电源

#### 3 说明

INA260 是一款数字输出电流、功率和电压监测计，具有一个集成高精度分流电阻的 I<sup>2</sup>C 和 SMBus™ 兼容接口。该器件支持高精度电流和功率测量并在独立于电源电压的共模电压范围内（0V 至 36V）实现过流检测。该器件是一款双向、低侧/高侧分流监测计，可测量流经内部电流感测电阻的电流。集成的精密电流感测电阻可使器件获得校准级别的测量精度以及超低温漂，并确保始终可实施针对感测电阻而优化的 Kelvin 布局。

INA260 在同一 I<sup>2</sup>C 兼容接口中具有多达 16 个可编程地址。数字接口允许通过编程设定报警阈值，可实现模数转换器 (ADC) 转换时间并求取平均值。为便于使用，可使用内部乘法器直接读取电流值（单位为安培）和功率值（单位为瓦）。

该器件由一个 2.7V 至 5.5V 单电源供电，电源电流为 310μA（典型值）。INA260 在 -40°C 至 +125°C 温度范围内额定运行，采用 16 引脚薄型小外形尺寸 (TSSOP) 封装。

器件信息(1)

器件型号	封装	封装尺寸 (标称值)
INA260	TSSOP (16)	5.00mm x 4.40mm

(1) 如需了解所有可用封装，请见数据表末尾的可订购产品附录。

#### 高侧感测应用

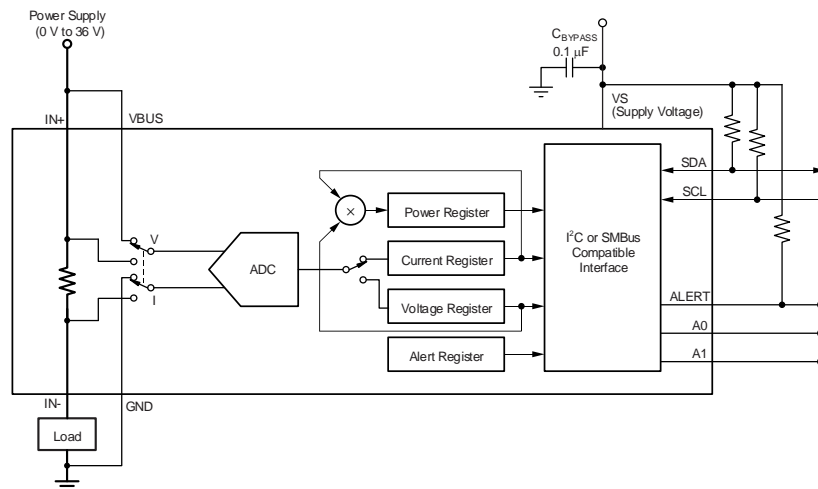

## 目录

<b>1</b>	特性 .....	<b>1</b>	8.5	Programming .....	<b>17</b>
<b>2</b>	应用 .....	<b>1</b>	8.6	Register Maps .....	<b>21</b>
<b>3</b>	说明 .....	<b>1</b>	<b>9</b>	<b>Application and Implementation</b> .....	<b>27</b>
<b>4</b>	修订历史记录 .....	<b>2</b>	9.1	Application Information .....	<b>27</b>
<b>5</b>	<b>Related Products</b> .....	<b>3</b>	9.2	Typical Application .....	<b>27</b>
<b>6</b>	<b>Pin Configuration and Functions</b> .....	<b>4</b>	<b>10</b>	<b>Power Supply Recommendations</b> .....	<b>29</b>
<b>7</b>	<b>Specifications</b> .....	<b>5</b>	<b>11</b>	<b>Layout</b> .....	<b>29</b>
7.1	Absolute Maximum Ratings .....	<b>5</b>	11.1	Layout Guidelines .....	<b>29</b>
7.2	ESD Ratings .....	<b>5</b>	11.2	Layout Example .....	<b>29</b>
7.3	Recommended Operating Conditions .....	<b>5</b>	<b>12</b>	器件和文档支持 .....	<b>30</b>
7.4	Thermal Information .....	<b>5</b>	12.1	器件支持 .....	<b>30</b>
7.5	Electrical Characteristics .....	<b>6</b>	12.2	文档支持 .....	<b>30</b>
7.6	Typical Characteristics .....	<b>8</b>	12.3	接收文档更新通知 .....	<b>30</b>
<b>8</b>	<b>Detailed Description</b> .....	<b>12</b>	12.4	社区资源 .....	<b>30</b>
8.1	Overview .....	<b>12</b>	12.5	商标 .....	<b>30</b>
8.2	Functional Block Diagram .....	<b>12</b>	12.6	静电放电警告 .....	<b>30</b>
8.3	Feature Description .....	<b>12</b>	12.7	Glossary .....	<b>30</b>
8.4	Device Functional Modes .....	<b>16</b>	<b>13</b>	机械、封装和可订购信息 .....	<b>30</b>

## 4 修订历史记录

注：之前版本的页码可能与当前版本有所不同。

<b>Changes from Revision B (December 2016) to Revision C</b>	<b>Page</b>
• 已更改 parameter symbol for current sense offset from: $V_{OS}$ to: $I_{OS}$ in <i>Electrical Characteristics</i> table .....	<b>8</b>

<b>Changes from Revision A (August 2016) to Revision B</b>	<b>Page</b>
• 已更改 器件状态至“量产数据” .....	<b>1</b>

## 5 Related Products

DEVICE	DESCRIPTION
<a href="#">INA250</a>	36-V, Low- or High-Side, Bidirectional, Zero-Drift Current-Shunt Monitor with Precision Integrated Shunt Resistor
<a href="#">INA226</a>	High-Side or Low-Side Measurement, Bi-Directional Current and Power Monitor with I <sup>2</sup> C Compatible Interface
<a href="#">INA230</a>	High- or Low-Side Measurement, Bidirectional Current/Power Monitor with I <sup>2</sup> C Interface
<a href="#">INA210</a> , <a href="#">INA211</a> , <a href="#">INA212</a> , <a href="#">INA213</a> , <a href="#">INA214</a> , <a href="#">INA215</a>	Voltage Output, Low- or High-Side Measurement, Bidirectional, Zero-Drift Series, Current-Shunt Monitors

## 6 Pin Configuration and Functions

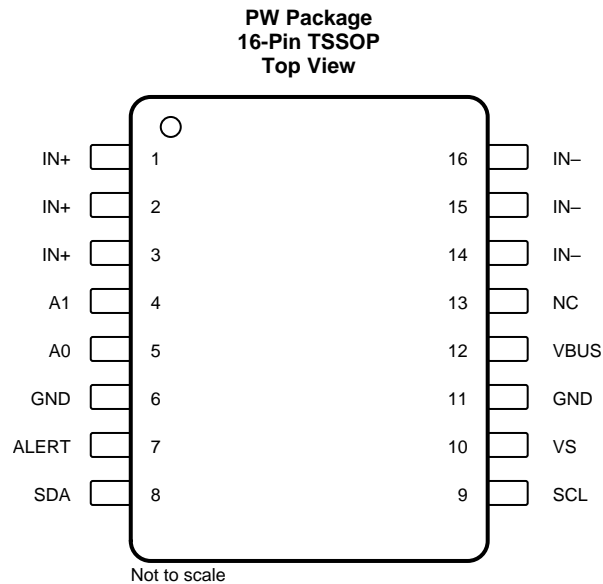

### Pin Functions

PIN		I/O	DESCRIPTION
NAME	NO.		
A0	5	Digital input	Address pin. Connect to GND, SCL, SDA, or VS. <a href="#">表 2</a> shows pin settings and corresponding addresses.
A1	4	Digital input	Address pin. Connect to GND, SCL, SDA, or VS. <a href="#">表 2</a> shows pin settings and corresponding addresses.
ALERT	7	Digital output	Multi-functional alert, open-drain output.
GND	6, 11	Analog	Ground pin for both analog and digital circuits.
IN+	1, 2, 3	Analog input	Connect to supply for high side current sensing or to load ground for low side sensing.
IN–	14, 15, 16	Analog input	Connect to load for high side current sensing or to board ground for low side sensing.
NC	13	—	No internal connection. Can be grounded or left floating.
SCL	9	Digital input	Serial bus clock line input.
SDA	8	Digital I/O	Serial bus data line, open-drain input/output.
VBUS	12	Analog input	Bus voltage monitor input.
VS	10	Analog	Power supply input, connect a 2.7 V to 5.5 V supply to this pin.

## 7 Specifications

### 7.1 Absolute Maximum Ratings

over operating free-air temperature range (unless otherwise noted)<sup>(1)</sup>

		MIN	MAX	UNIT
Analog input current	Continuous Conduction		±15	A
Analog inputs: IN+, IN–	Common-mode ( $V_{IN+} + V_{IN-}$ ) / 2	–0.3	40	V
Voltage	Supply, VS		6	V
	VBUS pin	–0.3	40	
	SDA, SCL, ALERT	–0.3	6	
	Address Pins, A0, A1	–0.3	VS + 0.3	
Open-drain digital output current, I <sub>OUT</sub>			10	mA
Temperature	Junction, T <sub>J</sub>		150	°C
	Storage, T <sub>stg</sub>	–65	150	

- (1) Stresses beyond those listed under *Absolute Maximum Ratings* may cause permanent damage to the device. These are stress ratings only, which do not imply functional operation of the device at these or any other conditions beyond those indicated under *Recommended Operating Conditions*. Exposure to absolute-maximum-rated conditions for extended periods may affect device reliability.

### 7.2 ESD Ratings

		VALUE	UNIT
V <sub>(ESD)</sub>	Electrostatic discharge	Human body model (HBM), per ANSI/ESDA/JEDEC JS-001 <sup>(1)</sup>	±2000
		Charged device model (CDM), per JEDEC specification JESD22-C101 <sup>(2)</sup>	±1000

- (1) JEDEC document JEP155 states that 500-V HBM allows safe manufacturing with a standard ESD control process.  
(2) JEDEC document JEP157 states that 250-V CDM allows safe manufacturing with a standard ESD control process.

### 7.3 Recommended Operating Conditions

over operating free-air temperature range (unless otherwise noted)

		MIN	NOM	MAX	UNIT
V <sub>CM</sub>	Common-mode input voltage	0		36	V
VS	Operating supply voltage	2.7		5.5	V
T <sub>A</sub>	Operating free-air temperature	–40		125	°C

### 7.4 Thermal Information

THERMAL METRIC <sup>(1)</sup>		INA260	UNIT
		PW (TSSOP)	
		16 PINS	
R <sub>θJA</sub>	Junction-to-ambient thermal resistance	115.6	°C/W
R <sub>θJC(top)</sub>	Junction-to-case (top) thermal resistance	50.1	°C/W
R <sub>θJB</sub>	Junction-to-board thermal resistance	46.8	°C/W
ψ <sub>JT</sub>	Junction-to-top characterization parameter	3.3	°C/W
ψ <sub>JB</sub>	Junction-to-board characterization parameter	46.5	°C/W
R <sub>θJC(bot)</sub>	Junction-to-case (bottom) thermal resistance	N/A	°C/W

- (1) For more information about traditional and new thermal metrics, see the *Semiconductor and IC Package Thermal Metrics* application report, [SPRA953](#).

## 7.5 Electrical Characteristics

 at  $T_A = 25^\circ\text{C}$ ,  $V_S = 3.3\text{ V}$ ,  $V_{IN+} = 12\text{ V}$ ,  $V_{SENSE} = (V_{IN+} - V_{IN-}) = 0\text{ mV}$  and  $V_{VBUS} = 12\text{ V}$  (unless otherwise noted)

PARAMETER		TEST CONDITIONS	MIN	TYP	MAX	UNIT
<b>INPUT</b>						
$V_{CM}$	Common-mode input range		0		36	V
	Bus voltage input range <sup>(1)</sup>		0		36	V
CMRR	Common-mode rejection	$0\text{ V} \leq V_{IN+} \leq 36\text{ V}$		0	150	$\mu\text{A/V}$
$I_{OS}$	Current sense offset, RTI <sup>(2)</sup>			$\pm 1.25$	$\pm 5$	mA
	Current sense offset drift, RTI <sup>(2)</sup>	$-40^\circ\text{C} \leq T_A \leq 125^\circ\text{C}$		1	50	$\mu\text{A}/^\circ\text{C}$
PSRR	Current sense offset voltage, RTI <sup>(2)</sup> vs power supply	$2.7\text{ V} \leq V_S \leq 5.5\text{ V}$		1.6	3	$\text{mA/V}$
$V_{OS}$	Bus offset voltage, RTI <sup>(2)</sup>			$\pm 1.25$	$\pm 7.5$	mV
	Bus offset voltage, RTI <sup>(2)</sup> vs temperature	$-40^\circ\text{C} \leq T_A \leq 125^\circ\text{C}$		0.6	40	$\mu\text{V}/^\circ\text{C}$
PSRR	Bus offset voltage, RTI <sup>(2)</sup> vs power supply			1.5		$\text{mV/V}$
$I_B$	Input bias current ( $I_{IN+}$ , $I_{IN-}$ pins)	$(I_{IN+}\text{ pin}) + (I_{IN-}\text{ pin})$ , $I_{SENSE} = 0\text{ A}$		17		$\mu\text{A}$
	VBUS input impedance			830		$\text{k}\Omega$
	Input leakage <sup>(3)</sup>	$(I_{IN+}\text{ pin}) + (I_{IN-}\text{ pin})$ , power-down mode		0.1	0.5	$\mu\text{A}$
<b>DC ACCURACY</b>						
System current sense gain error		$I_{SENSE} = -15\text{ A to }15\text{ A}$ , $T_A = 25^\circ\text{C}$		0.02%	0.15%	
		$I_{SENSE} = -10\text{ A to }10\text{ A}$ , $-40^\circ\text{C} \leq T_A \leq 125^\circ\text{C}$		0.2%	0.5%	
		$-40^\circ\text{C} \leq T_A \leq 125^\circ\text{C}$		10	35	$\text{ppm}/^\circ\text{C}$
Bus voltage gain error		$V_{BUS} = 0\text{ V to }36\text{ V}$ , $T_A = 25^\circ\text{C}$		0.02%	0.1%	
		$V_{BUS} = 0\text{ V to }36\text{ V}$ , $-40^\circ\text{C} \leq T_A \leq 125^\circ\text{C}$		0.1%	0.4%	
		$-40^\circ\text{C} \leq T_A \leq 125^\circ\text{C}$		15	40	$\text{ppm}/^\circ\text{C}$
<b>INTEGRATED ADC</b>						
	ADC native resolution			16		Bits
1-LSB step size		Current		1.25		mA
		Bus voltage		1.25		mV
		Power		10		mW
$t_{CT}$	ADC conversion time	CT bit = 000		140	154	$\mu\text{s}$
		CT bit = 001		204	224	
		CT bit = 010		332	365	
		CT bit = 011		588	646	
		CT bit = 100		1.1	1.21	ms
		CT bit = 101		2.116	2.328	
		CT bit = 110		4.156	4.572	
		CT bit = 111		8.244	9.068	
	Differential nonlinearity			$\pm 0.1$		LSB
<b>INTEGRATED SHUNT</b>						
	Package resistance	IN+ to IN-		4.5		$\text{m}\Omega$
	Maximum continuous current	$-40^\circ\text{C} \leq T_A \leq 85^\circ\text{C}$			$\pm 15$	A
	Short time overload change	$I_{SENSE} = 30\text{ A}$ for 5 seconds		$\pm 0.05\%$		

(1) Although the input range is 36 V, the full-scale range of the ADC scaling is 40.96 V; see the [Basic ADC Functions](#) section. Do not apply more than 36 V.

(2) RTI = Referred-to-input.

(3) Input leakage is positive (current flowing into the pin) for the conditions shown at the top of this table. Negative leakage currents can occur under different input conditions.

## Electrical Characteristics (continued)

at  $T_A = 25^\circ\text{C}$ ,  $V_S = 3.3\text{ V}$ ,  $V_{IN+} = 12\text{ V}$ ,  $V_{SENSE} = (V_{IN+} - V_{IN-}) = 0\text{ mV}$  and  $V_{VBUS} = 12\text{ V}$  (unless otherwise noted)

PARAMETER	TEST CONDITIONS	MIN	TYP	MAX	UNIT
Change due to thermal shock	$-65^\circ\text{C} \leq T_A \leq 150^\circ\text{C}$ , 500 cycles		$\pm 0.1\%$		
Resistance change to solder heat	260°C solder, 10 s		$\pm 0.1\%$		
High temperature exposure change	1000 hours, $T_A = 150^\circ\text{C}$		$\pm 0.15\%$		
Cold temperature storage change	24 hours, $T_A = -65^\circ\text{C}$		$\pm 0.025\%$		
<b>SMBus</b>					
SMBus timeout <sup>(4)</sup>			28	35	ms
<b>DIGITAL INPUT/OUTPUT</b>					
Input capacitance			3		pF
Leakage input current	$0\text{ V} \leq V_{SCL} \leq V_S$ , $0\text{ V} \leq V_{SDA} \leq V_S$ , $0\text{ V} \leq V_{ALERT} \leq V_S$ , $0\text{ V} \leq V_{A0} \leq V_S$ , $0\text{ V} \leq V_{A1} \leq V_S$		0.1	1	$\mu\text{A}$
$V_{IH}$ High-level input voltage		$0.7 \times V_S$		6	V
$V_{IL}$ Low-level input voltage		0		$0.3 \times V_S$	V
$V_{OL}$ Low-level output voltage, SDA, ALERT	$I_{OL} = 3\text{ mA}$	0		0.4	V
SDA, SCL Hysteresis			500		mV
<b>POWER SUPPLY</b>					
Operating supply range		2.7		5.5	V
$I_Q$ Quiescent current			310	420	$\mu\text{A}$
Quiescent current, power-down (shutdown) mode			0.5	2	$\mu\text{A}$
$V_{POR}$ Power-on reset threshold			2		V

(4) SMBus timeout in the INA260 resets the interface any time SCL is low for more than 28 ms.

### 7.6 Typical Characteristics

At  $T_A = 25^\circ\text{C}$ ,  $V_S = 3.3\text{ V}$ ,  $V_{IN+} = 12\text{ V}$ ,  $V_{SENSE} = (V_{IN+} - V_{IN-}) = 0\text{ mV}$  and  $V_{VBUS} = 12\text{ V}$ , unless otherwise noted.



图 1. Current Sense Offset Production Distribution



图 2. Current Sense Offset vs Temperature

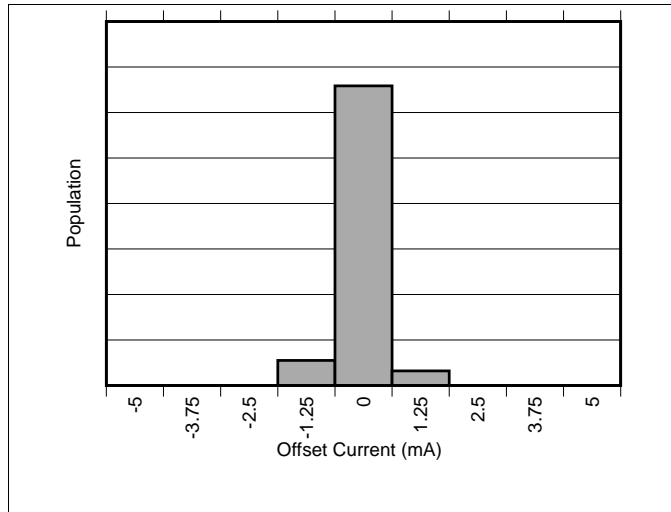

图 3. Current Sense Common-Mode Rejection Ratio vs Temperature

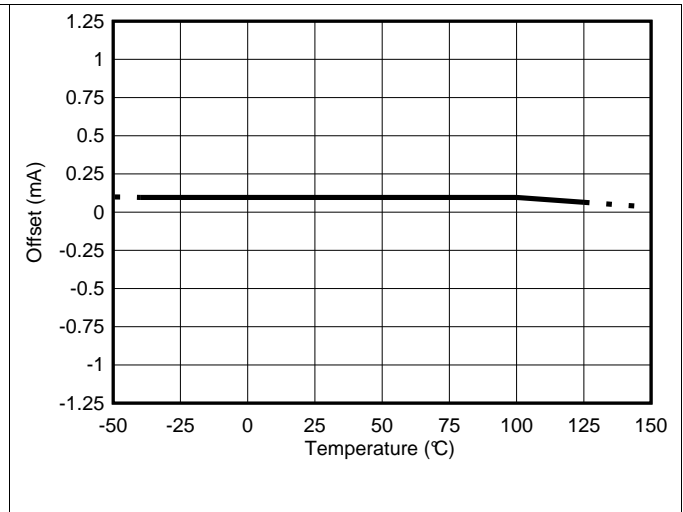

图 4. Current Sense Gain Error Production Distribution

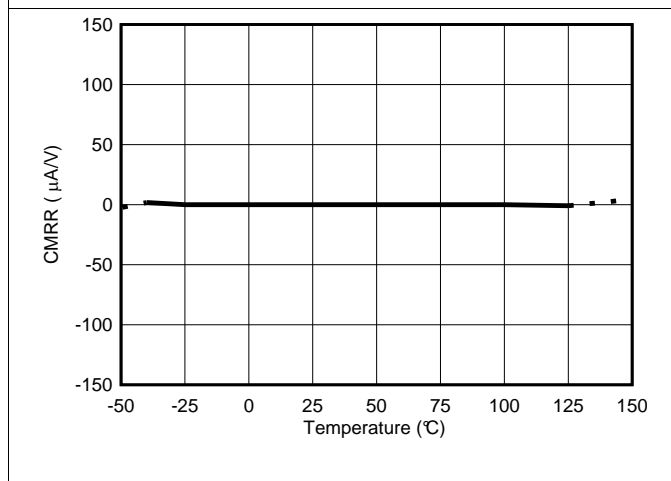

图 5. Current Sense Gain Error vs Temperature

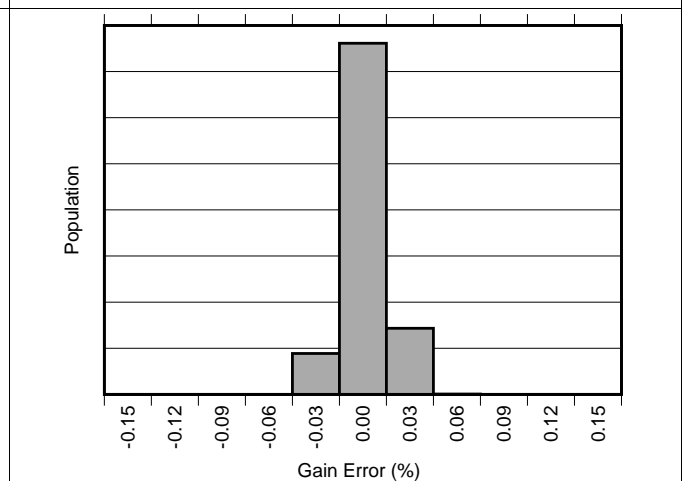

图 6. Current Sense Gain Error vs Common-Mode Voltage

Typical Characteristics (接下页)

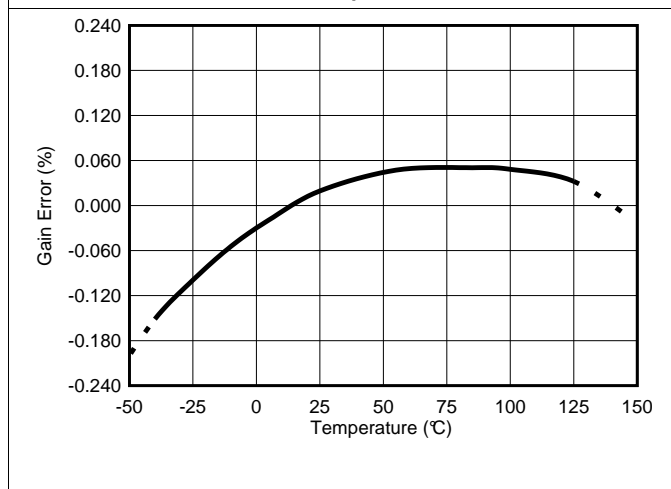
At  $T_A = 25^\circ\text{C}$ ,  $V_S = 3.3\text{ V}$ ,  $V_{IN+} = 12\text{ V}$ ,  $V_{SENSE} = (V_{IN+} - V_{IN-}) = 0\text{ mV}$  and  $V_{VBUS} = 12\text{ V}$ , unless otherwise noted.

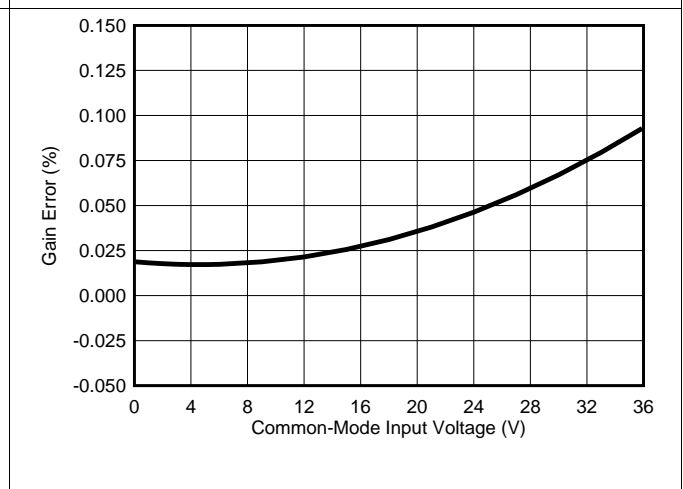

图 7. Bus Offset Voltage Production Distribution



图 8. Bus Offset Voltage vs Temperature

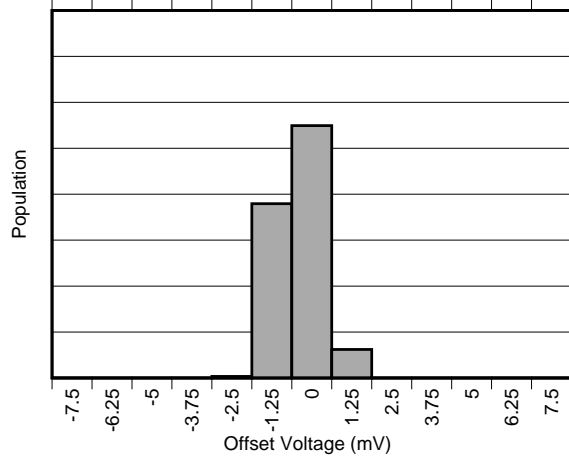

图 9. Bus Gain Error Production Distribution

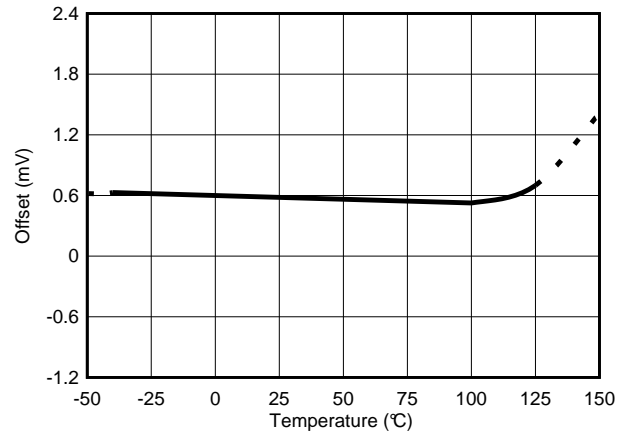

图 10. Bus Gain Error vs Temperature

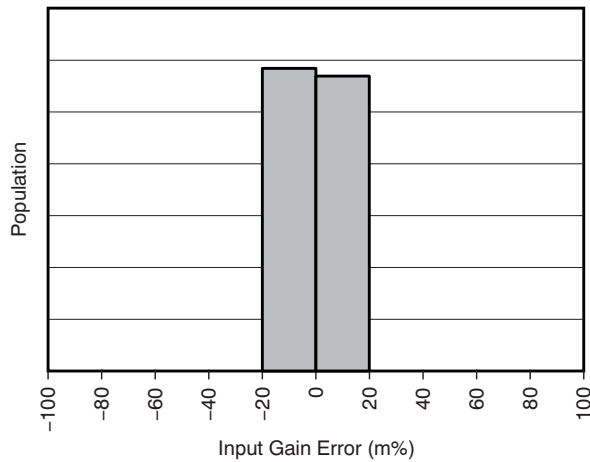

图 11. Power Gain Error vs Temperature

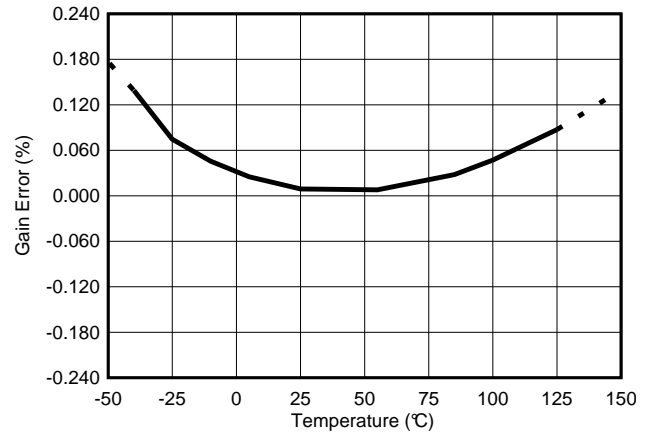

图 12. Power Offset Error vs Temperature

Typical Characteristics (接下页)

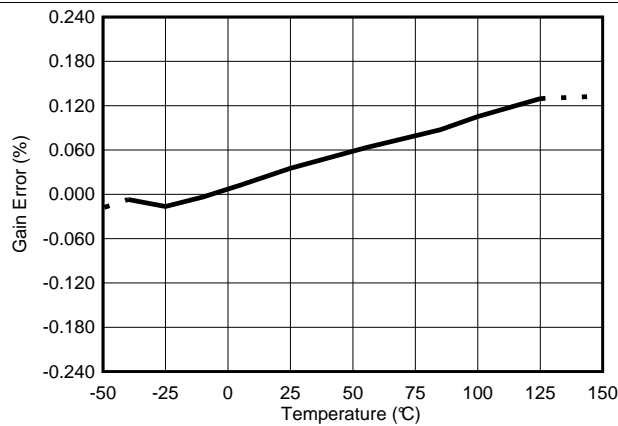
At  $T_A = 25^\circ\text{C}$ ,  $V_S = 3.3\text{ V}$ ,  $V_{IN+} = 12\text{ V}$ ,  $V_{SENSE} = (V_{IN+} - V_{IN-}) = 0\text{ mV}$  and  $V_{VBUS} = 12\text{ V}$ , unless otherwise noted.

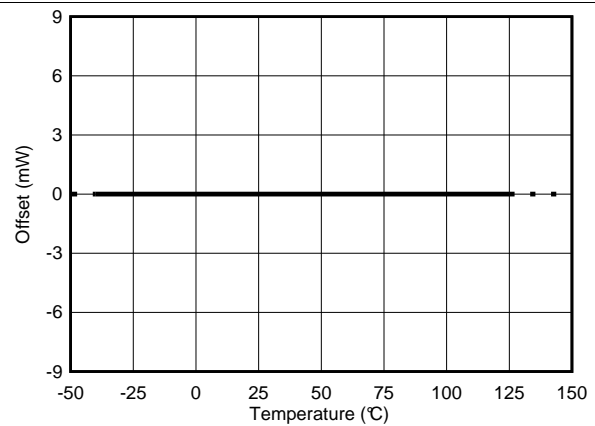
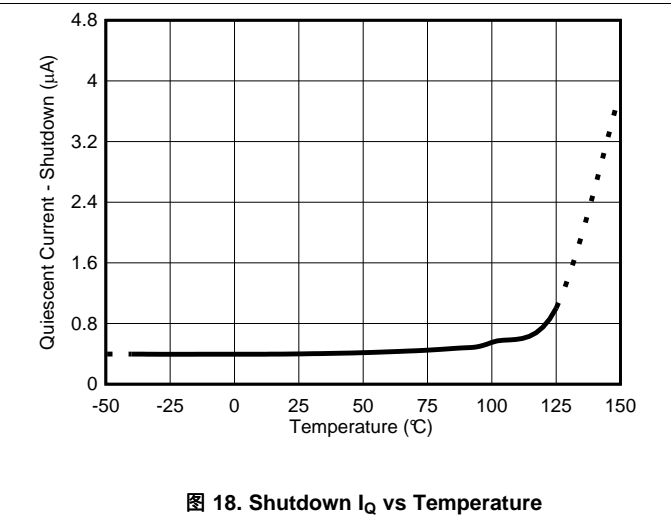
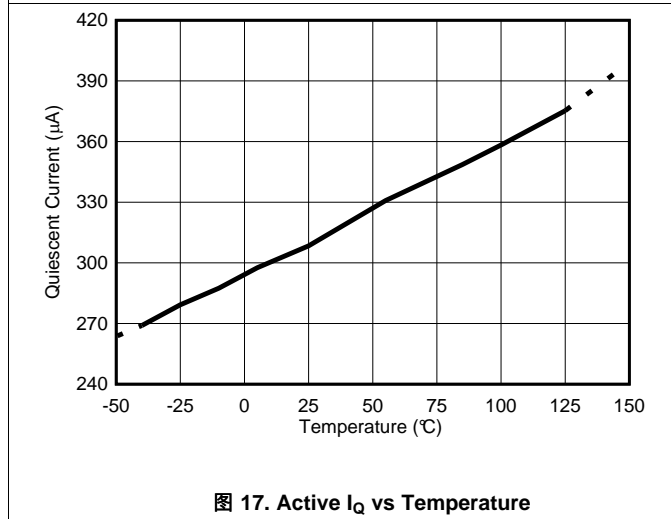
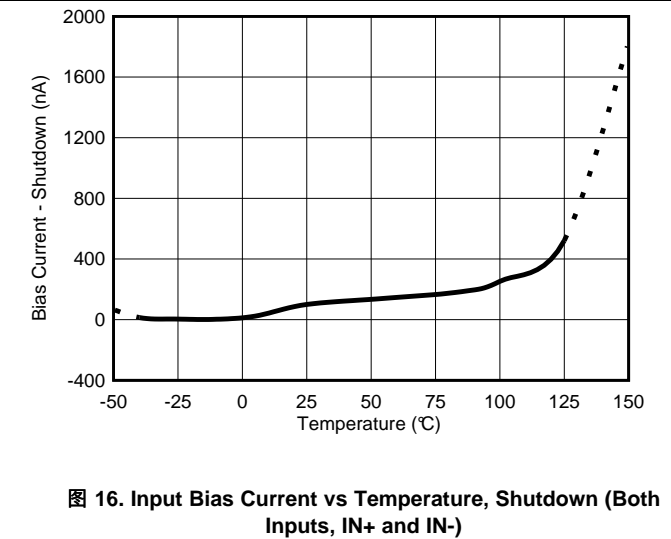
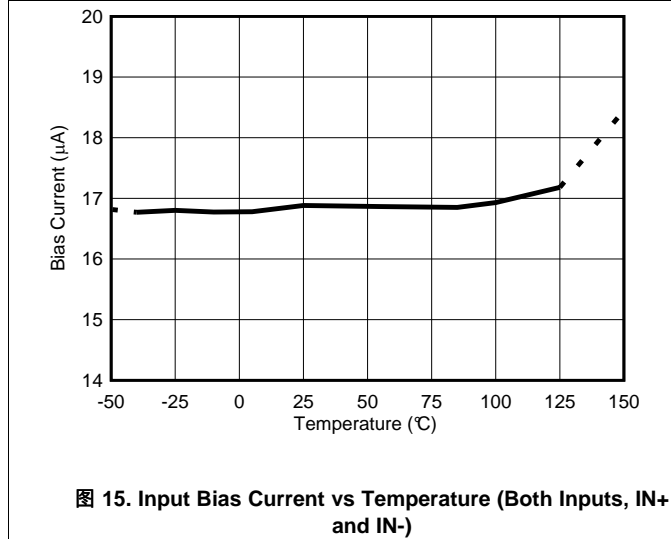
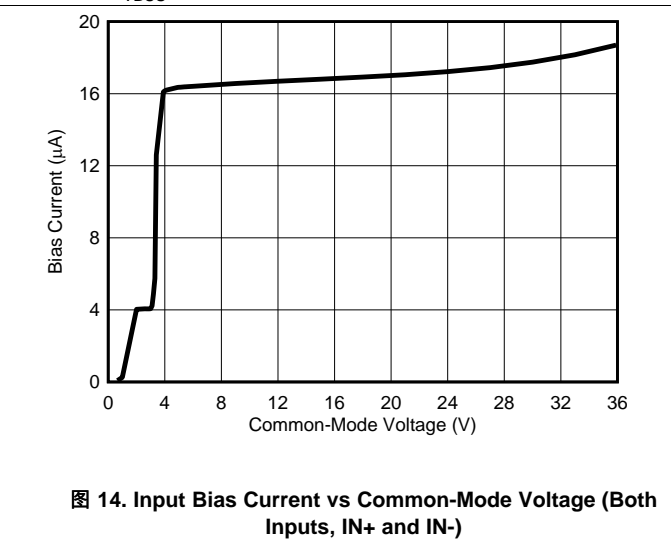
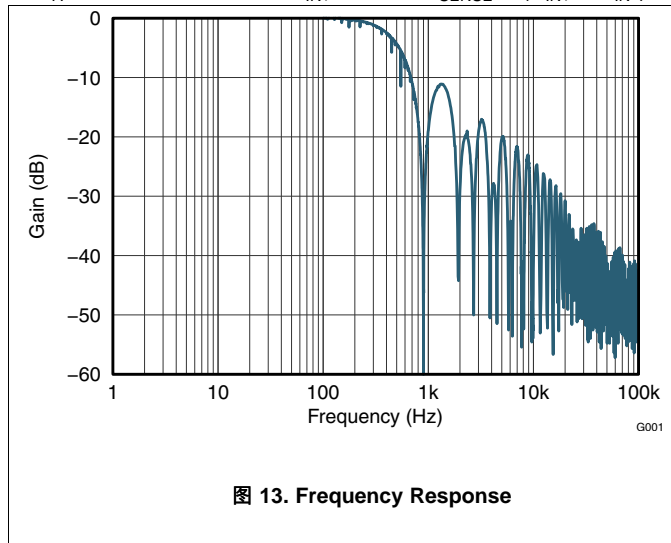

Typical Characteristics (接下页)

At  $T_A = 25^\circ\text{C}$ ,  $V_S = 3.3\text{ V}$ ,  $V_{IN+} = 12\text{ V}$ ,  $V_{SENSE} = (V_{IN+} - V_{IN-}) = 0\text{ mV}$  and  $V_{VBUS} = 12\text{ V}$ , unless otherwise noted.



图 19. Active  $I_Q$  vs  $I^2C$  Clock Frequency

图 20. Shutdown  $I_Q$  vs  $I^2C$  Clock Frequency

## 8 Detailed Description

### 8.1 Overview

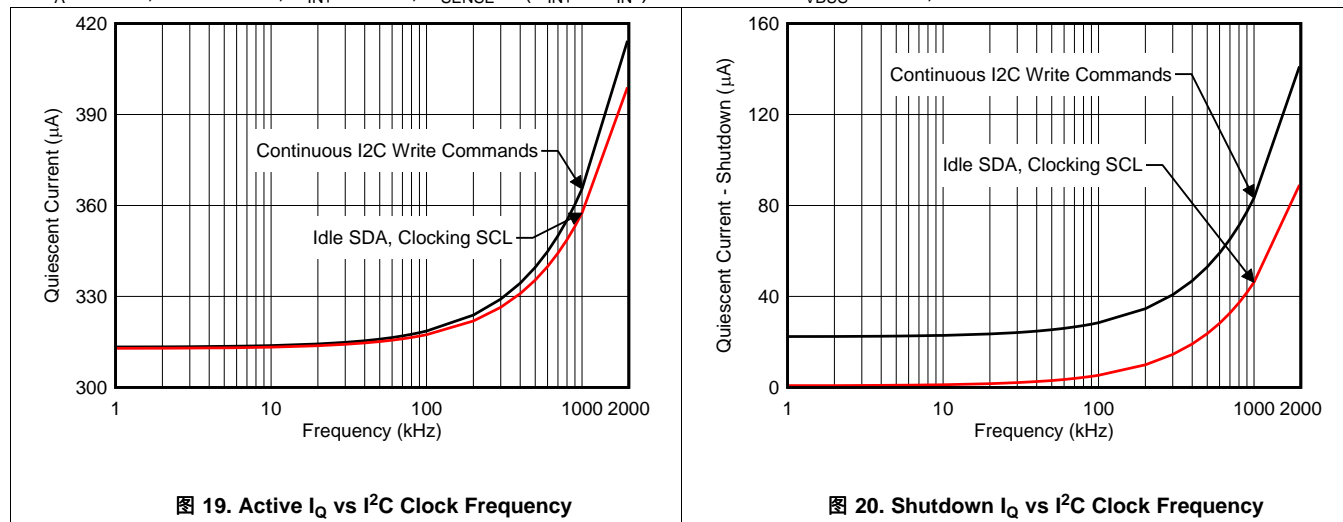
The INA260 is an integrated shunt digital current sense amplifier with an I<sup>2</sup>C- and SMBus-compatible interface. It provides digital current, voltage, and power readings necessary for accurate decision-making in precisely-controlled systems. Programmable registers allow flexible configuration for conversion times as well as continuous-versus-triggered operation. Detailed register information appears at the end of this data sheet, beginning with 表 4. See the [Functional Block Diagram](#) section for a block diagram of the INA260 device.

### 8.2 Functional Block Diagram

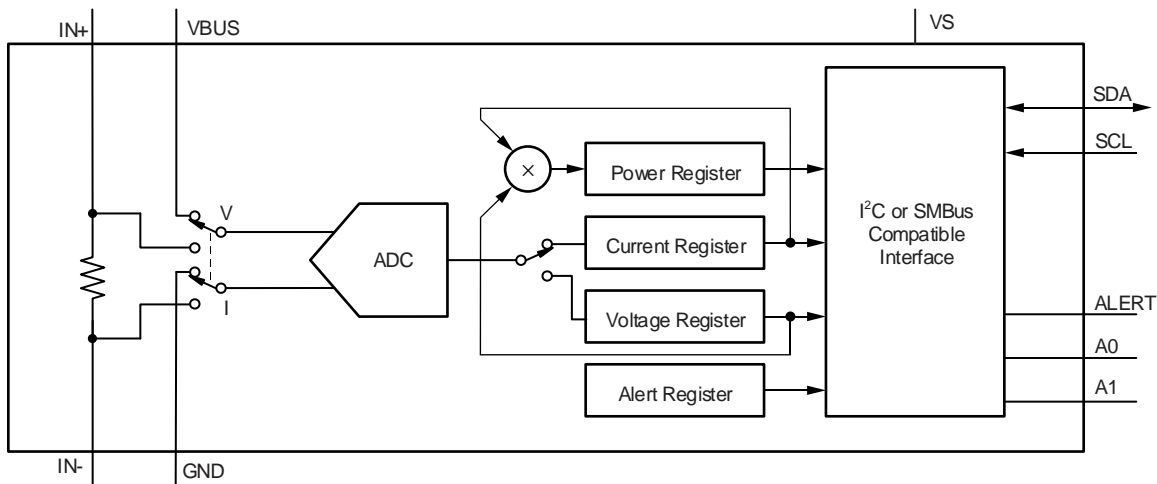

### 8.3 Feature Description

#### 8.3.1 Integrated Shunt Resistor

The INA260 features a precise, low-drift, current-sensing resistor to allow for precision measurements over the entire specified temperature range of  $-40^{\circ}\text{C}$  to  $+125^{\circ}\text{C}$ . The integrated current-sensing resistor ensures measurement stability over temperature as well as simplifying printed-circuit board (PCB) layout difficulties common in high precision current sensing measurements.

The onboard current-sensing resistor is designed as a 4-wire (or Kelvin) connected resistor that enables accurate measurements through a force-sense connection. The Kelvin connections to the shunt are done internally eliminating many of the parasitic impedances commonly found in typical very-low sensing-resistor level measurements. Although the shunt resistor can be accessed through the IN+ and IN- pins, this resistor is not intended to be used as a stand-alone component. The INA260 is internally calibrated to ensure that the current-sensing resistor and current-sensing amplifier are both precisely matched to one another.

The INA260 has approximately  $4.5\text{ m}\Omega$  of total resistance between the IN+ and IN- pins.  $2\text{ m}\Omega$  of this total package resistance is a precisely-controlled resistance from the Kelvin-connected current-sensing resistor used by the internal analog to digital converter (ADC). The power dissipation requirements of the system and package are based on the total  $4.5\text{-m}\Omega$  package resistance. The heat dissipated across the package when current flows through the device ultimately determines the maximum current that can be safely handled by the package. The current consumption of the silicon is relatively low, leaving the total package resistance carrying the high load current as the primary contributor to the total power dissipation of the package. The maximum safe-operating current level is set to ensure that the heat dissipated across the package is limited so that no damage to the resistor or the package itself occurs or that the internal junction temperature of the silicon does not exceed a  $150^{\circ}\text{C}$  limit.

## Feature Description (接下页)

External factors (such as ambient temperature, external air flow, and PCB layout) can contribute to how effectively the heat developed as a result of the current flowing through the total package resistance can be removed from within the device. Under the conditions of no air flow, a maximum ambient temperature of 85°C, and 1-oz. copper input power planes, the INA260 can accommodate continuous current levels up to 15 A. As shown in 图 21, the current handling capability is derated at temperatures above the 85°C level with safe operation up to 10 A at a 125°C ambient temperature. With air flow and larger 2-oz. copper input power planes, the INA260 can safely accommodate continuous current levels up to 15 A over the entire -40°C to +125°C temperature range.



图 21. Maximum Current vs Temperature

### 8.3.2 Over-Current Capability

The INA260 features a physical shunt resistance that is able to withstand current levels higher than the continuous handling limit of 15 A without sustaining damage to the current-sensing resistor or the current-sensing amplifier if the excursions are very brief. 图 22 shows the maximum overload current versus time curve for the INA260.

#### CAUTION

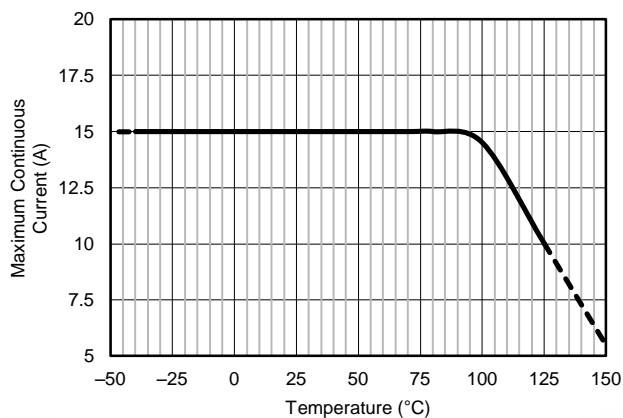
Operation at or above this curve, 图 22, can result in device damage or permanent erroneous current readings.

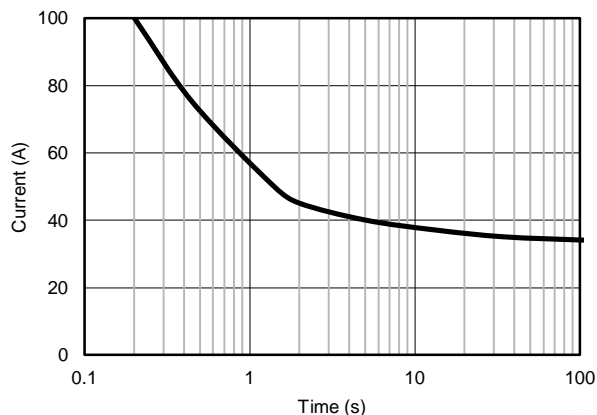

$T_A = 25^\circ\text{C}$

图 22. Maximum Overload Current vs Time

## Feature Description (接下页)

### 8.3.3 Basic ADC Functions

The INA260 device performs two measurements on the power-supply bus of interest. The current which is internally calculated by measuring the voltage developed across a known internal shunt resistor, and the power supply bus voltage from the external VBUS pin to ground.

The device is typically powered by a separate supply that can range from 2.7 V to 5.5 V. The bus that is being monitored can range in voltage from 0 V to 36 V. Based on the fixed 1.25-mV LSB for the Bus Voltage Register that a full-scale register results in a 40.96 V value.

注

**Do not apply more than 36 V of actual voltage to the input pins.**

There are no special considerations for power-supply sequencing because the common-mode input range and power-supply voltage are independent of each other; therefore, the bus voltage can be present with the supply voltage off, and vice-versa.

The device has two operating modes, continuous and triggered, that determine how the ADC operates following these conversions. When the device is in the normal operating mode (that is, MODE bits of the Configuration Register (00h) are set to '111'), it continuously converts an internal shunt voltage reading followed by a bus voltage reading. After the measurement of the internal shunt voltage reading, the current value is calculated. This current value is then used to calculate the power result. These values are subsequently stored in an accumulator, and the measurement/calculation sequence repeats until the number of averages set in the Configuration Register (00h) is reached. Following every sequence, the present set of values, measured and calculated, are appended to previously collected values. After all of the averaging has been completed, the final values for bus voltage, current, and power are updated in the corresponding registers that can then be read. These values remain in the data output registers until they are replaced by the next fully completed conversion results. Reading the data output registers does not affect a conversion in progress.

The mode control in the Configuration Register (00h) also permits selecting modes to convert only the current or the bus voltage in order to further allow the user to configure the monitoring function to fit the specific application requirements.

In triggered mode, writing any of the triggered convert modes into the Configuration Register (00h) (that is, MODE bits of the Configuration Register (00h) are set to '001', '010', or '011') triggers a single-shot conversion. This action produces a single set of measurements; thus, to trigger another single-shot conversion, the Configuration Register (00h) must be written to a second time, even if the mode does not change.

In addition to the two operating modes (continuous and triggered), the device also has a power-down mode that reduces the quiescent current and turns off current into the device inputs, reducing the impact of supply drain when the device is not being used. Full recovery from power-down mode requires 40  $\mu$ s. The registers of the device can be written to and read from while the device is in power-down mode. The device remains in power-down mode until one of the active modes settings are written into the Configuration Register (00h) .

Although the device can be read at any time, and the data from the last conversion remain available, the Conversion Ready flag bit (Mask/Enable Register, CVRF bit) is provided to help coordinate one-shot or triggered conversions. The Conversion Ready flag (CVRF) bit is set after all conversions, averaging, and multiplication operations are complete.

The Conversion Ready flag (CVRF) bit clears under these conditions:

- Writing to the Configuration Register (00h), except when configuring the MODE bits for power-down mode; or
- Reading the Mask/Enable Register (06h)

#### 8.3.3.1 Power Calculation

The power is calculated following current and bus voltage measurements; see [图 23](#). Calculations for both the current and power are performed in the background and do not add to the overall conversion time. These current and power values are considered intermediate results (unless the averaging is set to 1) and are stored in an internal accumulation register, not the corresponding output registers. Following every measured sample, the newly-calculated values for current and power are appended to this accumulation register until all of the samples have been measured and averaged based on the number of averages set in the Configuration Register (00h).

## Feature Description (接下页)

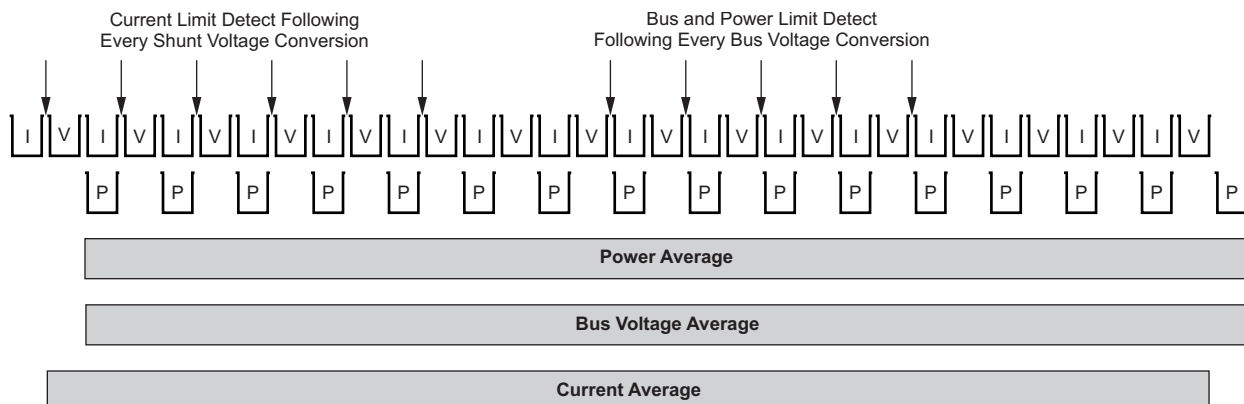

NOTE: I = current, V = voltage, and P = power.

图 23. Power Calculation Scheme

In addition to the current and power accumulating after every sample, the bus voltage measurement is also collected. After all of the samples have been measured and the corresponding current and power calculations have been made, the accumulated average for each of these parameters is then loaded to the corresponding output registers, where they can be read.

### 8.3.3.2 ALERT Pin

The INA260 has a single Alert Limit Register (07h), that allows the ALERT pin to be programmed to respond to a single user-defined event or to a Conversion Ready notification if desired. The Mask/Enable Register allows the user to select from one of the five available functions to monitor as well as setting the Conversion Ready bit to control the response of the ALERT pin. Based on the function being monitored, enter a value into the Alert Limit Register to set the corresponding threshold value that asserts the ALERT pin.

The ALERT pin allows for one of several available alert functions to be monitored to determine if a user-defined threshold has been exceeded. The five alert functions that can be monitored are:

- Shunt Over Current-Limit (OCL)
- Shunt Under Current-Limit (UCL)
- Bus Voltage Over-Limit (BOL)
- Bus Voltage Under-Limit (BUL)
- Power Over-Limit (POL)

The ALERT pin is an open-drain output. This pin is asserted when the alert function selected in the Mask/Enable Register exceeds the value programmed into the Alert Limit Register. Only one of these alert functions can be enabled and monitored at a time. If multiple alert functions are enabled, the selected function in the highest significant bit position takes priority and responds to the Alert Limit Register value. For example, if the shunt over and under current limit functions are both selected, the Alert pin asserts when the shunt current exceeds the value in the Alert Limit Register.

The Conversion Ready state of the device can also be monitored at the ALERT pin to inform the user when the device has completed the previous conversion and is ready to begin a new conversion. Conversion Ready can be monitored at the ALERT pin along with one of the alert functions. If an alert function and the Conversion Ready are both enabled to be monitored at the ALERT pin, after the ALERT pin is asserted, the Mask/Enable Register must be read following the alert to determine the source of the alert. By reading the Conversion Ready Flag (CVRF, bit 3), and the Alert Function Flag (AFF, bit 4) in the Mask/Enable Register, the source of the alert can be determined. If the Conversion Ready feature is not desired and the CNVR bit is not set, the ALERT pin only responds to an exceeded alert limit based on the alert function enabled.

If the alert function is not used, the ALERT pin can be left floating without impacting the operation of the device.

## Feature Description (接下页)

Refer to 图 23 to see the relative timing of when the value in the Alert Limit Register is compared to the corresponding converted value. For example, if the alert function that is enabled is Shunt Overcurrent-Limit (OCL), following every shunt current conversion the value in the Alert Limit Register is compared to the measured shunt voltage to determine if the measurements has exceeded the programmed limit. The AFF, bit 4 of the Mask/Enable Register, asserts high any time the measured voltage exceeds the value programmed into the Alert Limit Register. In addition to the AFF being asserted, the Alert pin is asserted based on the Alert Polarity Bit (APOL, bit 1 of the Mask/Enable Register). If the Alert Latch is enabled, the AFF and Alert pin remain asserted until either the Configuration Register (00h) is written to or the Mask/Enable Register is read.

The Bus Voltage alert functions compare the measured bus voltage to the Alert Limit Register following every bus voltage conversion and assert the AFF bit and ALERT pin if the limit threshold is exceeded.

The Power Over-Limit alert function is also compared to the calculated power value following every bus voltage measurement conversion and asserts the AFF bit and ALERT pin if the limit threshold is exceeded.

## 8.4 Device Functional Modes

### 8.4.1 Averaging and Conversion Time Considerations

The INA260 device offers programmable conversion times ( $t_{CT}$ ) for both the shunt current and bus voltage measurements. The conversion times for these measurements can be selected from as fast as 140  $\mu$ s to as long as 8.244 ms. The conversion time settings, along with the programmable averaging mode, allow the device to be configured to optimize the available timing requirements in a given application. For example, if a system requires that data be read every 5 ms, the device could be configured with the conversion times set to 588  $\mu$ s for both shunt and bus voltage measurements and the averaging mode set to 4. This configuration results in the data updating approximately every 4.7 ms. The device could also be configured with a different conversion time setting for the shunt and bus voltage measurements. This type of approach is common in applications where the bus voltage tends to be relatively stable. This situation allows reduced time focused on the bus voltage measurement relative to the shunt voltage measurement. The shunt voltage conversion time could be set to 4.156 ms with the bus voltage conversion time set to 588  $\mu$ s and with the averaging mode set to 1. This configuration also results in data updating approximately every 4.7 ms.

There are trade-offs associated with the settings for conversion time and the averaging mode used. The averaging feature can significantly improve the measurement accuracy by effectively filtering the signal. This approach allows the device to reduce any noise in the measurement that may be caused by noise coupling into the signal. A greater number of averages enables the device to be more effective in reducing the noise component of the measurement.

The conversion times selected can also have an impact on the measurement accuracy. 图 24 shows multiple conversion times to illustrate the impact of noise on the measurement. To achieve the highest accuracy measurement possible, use a combination of the longest allowable conversion times and highest number of averages, based on the timing requirements of the system.



图 24. Noise vs Conversion Time

## 8.5 Programming

### 8.5.1 Calculating Returned Values

The LSB size for the Bus Voltage Register (02h), Current Register, and Power Register are fixed and are shown in 表 1. To calculate any of the values for current, voltage or power take the decimal value returned by the device and multiply that value by the LSB size. For example, the LSB for the bus voltage is 1.25 mV/bit, if the device returns a decimal value of 9584 (2570h), the value of the bus voltage is calculated to be  $1.25 \text{ mV} \times 9584 = 11.98 \text{ V}$ . Because the INA260 supports current measurements in either direction, the returned value for negative currents (currents flowing from IN- to IN+) is represented in two's complement format. Returned values for power will always be positive even when the current is negative.

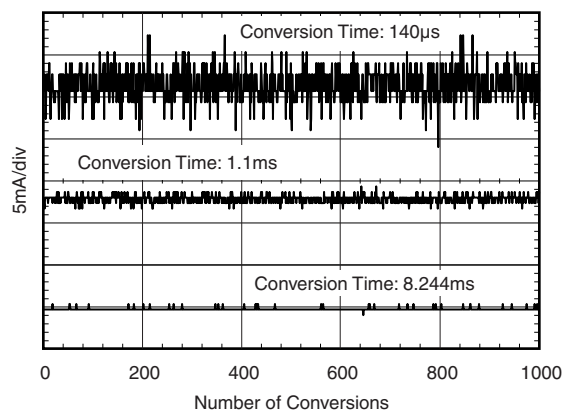
**表 1. Calculating Current and Power<sup>(1)</sup>**

REGISTER NAME	ADDRESS	CONTENTS	DEC	LSB	VALUE
Current Register	01h	2710h	10000	1.25 mA	12.5 A
Bus Voltage Register	02h	2570h	9584	1.25 mV	11.98 V
Power Register	03h	3A7Fh	14975	10 mW	149.75 W

(1) Conditions: Load = 12.5 A,  $V_{CM} = 11.98 \text{ V}$ .

### 8.5.2 Default Settings

The default power-up states of the registers are shown in the [Register Maps](#) section of this data sheet. These registers are volatile, and if programmed to a value other than the default values shown in 表 4, they must be re-programmed at every device power-up.

### 8.5.3 Communications Bus Overview

The INA260 offers compatibility with both I<sup>2</sup>C and SMBus interfaces. The I<sup>2</sup>C and SMBus protocols are essentially compatible with one another.

The I<sup>2</sup>C interface is used throughout this data sheet as the primary example, with SMBus protocol specified only when a difference between the two systems is discussed. Two lines, SCL and SDA, connect the device to the bus. Both SCL and SDA connect to the bus and require external pullup resistors.

The device that initiates a data transfer is called a *master*, and the devices controlled by the master are *slaves*. The bus must be controlled by a master device that generates the serial clock (SCL), controls the bus access, and generates START and STOP conditions. The SCL pin on the INA260 is an input only and will not stretch the clock by holding the clock line low.

To address a specific device, the master initiates a start condition by pulling the data signal line (SDA) from a high to a low logic level while SCL is high. All slaves on the bus shift in the slave address byte on the rising edge of SCL, with the last bit indicating whether a read or write operation is intended. During the ninth clock pulse, the slave being addressed responds to the master by generating an Acknowledge and pulling SDA low.

Data transfer is then initiated and eight bits of data are sent, followed by an *Acknowledge* bit. During data transfer, SDA must remain stable while SCL is high. Any change in SDA while SCL is high is interpreted as a start or stop condition.

After all data have been transferred, the master generates a stop condition, indicated by pulling SDA from low to high while SCL is high. The device includes a 28-ms timeout on its interface to prevent locking up the bus.

#### 8.5.3.1 Serial Bus Address

To communicate with the device, the master must first address the INA260 through a slave address byte. The slave address byte consists of seven address bits and a direction bit that indicates whether the action is to be a read or write operation.

The device has two address pins, A0 and A1 that can be connected to GND, VS, SCL or SDA to set the desired address. 表 2 lists the pin connections for each of the 16 possible addresses. The device samples the state of pins A0 and A1 on every bus communication in order to establish the pin states before any activity on the interface occurs.

**表 2. Address Pins and Slave Addresses**

A1	A0	SLAVE ADDRESS
GND	GND	1000000
GND	VS	1000001
GND	SDA	1000010
GND	SCL	1000011
VS	GND	1000100
VS	VS	1000101
VS	SDA	1000110
VS	SCL	1000111
SDA	GND	1001000
SDA	VS	1001001
SDA	SDA	1001010
SDA	SCL	1001011
SCL	GND	1001100
SCL	VS	1001101
SCL	SDA	1001110
SCL	SCL	1001111

### 8.5.3.2 Serial Interface

The INA260 operates only as a slave device on both the I<sup>2</sup>C bus and the SMBus. Connections to the bus are made through the open-drain SDA and SCL lines. The SDA and SCL pins feature integrated spike suppression filters and Schmitt triggers to minimize the effects of input spikes and bus noise. Although the device integrates spike suppression into the digital I/O lines, proper layout techniques help minimize the amount of coupling into the communication lines. This noise introduction could occur from capacitively coupling signal edges between the two communication lines themselves or from other switching noise sources present in the system. Routing traces in parallel with ground in between layers on a PCB typically reduces the effects of coupling between the communication lines. Shielded communication lines reduces the possibility of unintended noise coupling into the digital I/O lines that could be incorrectly interpreted as start or stop commands.

The INA260 supports the transmission protocol for fast mode (1 kHz to 400 kHz) and high-speed mode (1 kHz to 2.94 MHz). All data bytes are transmitted most significant byte first.

### 8.5.3.3 Writing to and Reading From the INA260

Accessing a specific register on the INA260 is accomplished by writing the appropriate value to the register pointer. See 表 4 for a complete list of registers and corresponding addresses. The value for the register pointer (as shown in 图 28) is the first byte transferred after the slave address byte with the R/W bit low. Every write operation to the device requires a value for the register pointer.

Writing to a register begins with the first byte transmitted by the master. This byte is the slave address, with the R/W bit low. The device then acknowledges receipt of a valid address. The next byte transmitted by the master is the address of the register which data is written to. This register address value updates the register pointer to the desired register. The next two bytes are written to the register addressed by the register pointer. The device acknowledges receipt of each data byte. The master may terminate data transfer by generating a start or stop condition.

When reading from the device, the last value stored in the register pointer by a write operation determines which register is read during a read operation. To change the register pointer for a read operation, a new value must be written to the register pointer. This write is accomplished by issuing a slave address byte with the R/W bit low, followed by the register pointer byte. No additional data are required. The master then generates a start condition and sends the slave address byte with the R/W bit high to initiate the read command. The next byte is transmitted by the slave and is the most significant byte of the register indicated by the register pointer. This byte is followed by an *Acknowledge* from the master; then the slave transmits the least significant byte. The master acknowledges receipt of the data byte. The master may terminate data transfer by generating a *Not-Acknowledge* after receiving any data byte, or generating a start or stop condition. If repeated reads from the same register are desired, it is not necessary to continually send the register pointer bytes; the device retains the register pointer value until it is changed by the next write operation.

图 25 shows the write operation timing diagram. 图 26 shows the read operation timing diagram.

注

Register bytes are sent most-significant byte first, followed by the least significant byte.

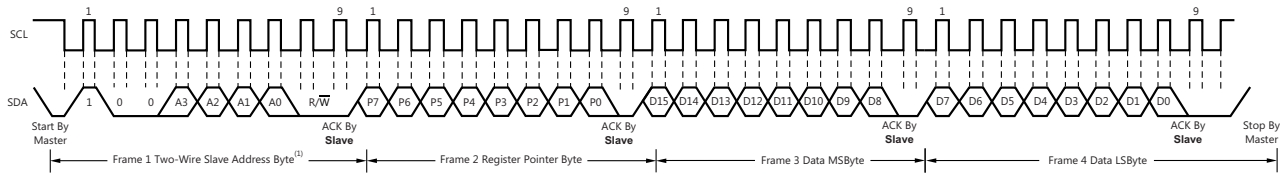

(1) The value of the Slave Address byte is determined by the settings of the A0 and A1 pins. See 表 2.

图 25. Timing Diagram for Write Word Format

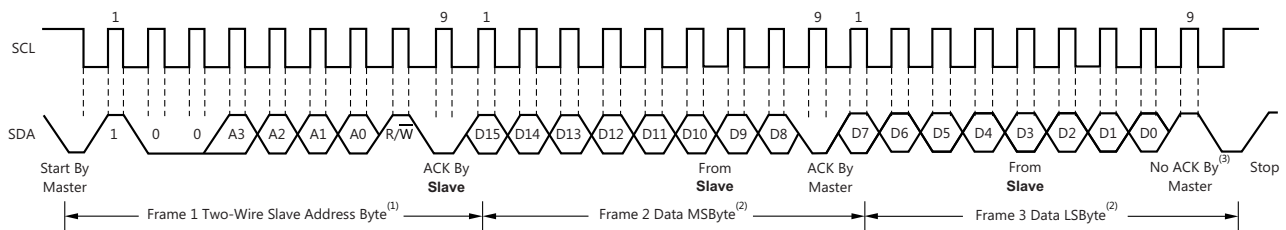

(1) The value of the Slave Address byte is determined by the settings of the A0 and A1 pins. See 表 2.

(2) Read data is from the last register pointer location. If a new register is desired, the register pointer must be updated. See 图 28.

(3) ACK by Master can also be sent.

图 26. Timing Diagram for Read Word Format

图 27 provides a timing diagram for the SMBus Alert response operation. 图 28 illustrates a typical register pointer configuration.

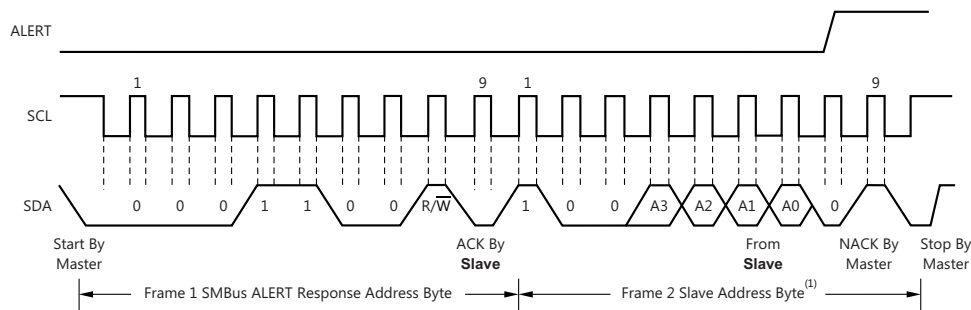

(1) The value of the Slave Address Byte is determined by the settings of the A0 and A1 pins. See 表 2.

图 27. Timing Diagram for SMBus ALERT Response

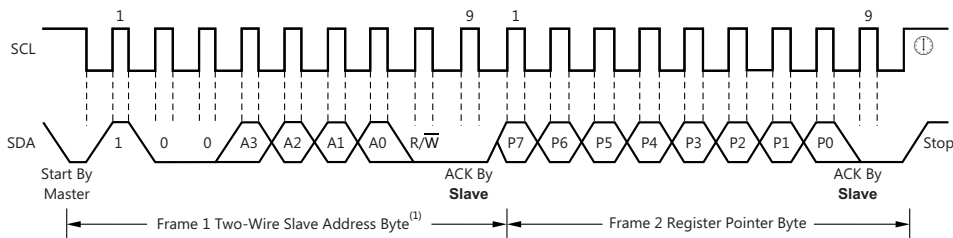

(1) The value of the Slave Address Byte is determined by the settings of the A0 and A1 pins. See 表 2.

图 28. Typical Register Pointer Set

### 8.5.3.3.1 High-Speed I<sup>2</sup>C Mode

To initiate high-speed mode operation, the master generates a start condition followed by a valid serial byte containing high-speed (HS) master code *00001XXX*. This transmission is made in fast (400 kHz) or standard (100 kHz) (F/S) mode at no more than 400 kHz. When the INA260 receives the high-speed code it does not send an acknowledgement but does change the internal logic deglitch filters to support high-speed operation.

The master then generates a repeated start condition (a repeated start condition has the same timing as the start condition). After this repeated start condition, the protocol is the same as F/S mode, except that transmission speeds up to 2.94 MHz are allowed. Instead of using a stop condition, use repeated start conditions to secure the bus in HS-mode. A stop condition ends the HS-mode and switches all the internal filters of the device to support the F/S mode. See [图 29](#) and [表 3](#) for relevant fast mode and high-speed mode timing requirements.



图 29. Bus Timing Diagram

表 3. Bus Timing Diagram Definitions<sup>(1)</sup>

PARAMETER		FAST MODE		HIGH-SPEED MODE		UNIT
		MIN	MAX	MIN	MAX	
SCL operating frequency	$f_{(SCL)}$	0.001	0.4	0.001	2.94	MHz
Bus free time between stop and start conditions	$t_{(BUF)}$	600		160		ns
Hold time after repeated START condition. After this period, the first clock is generated.	$t_{(HDSTA)}$	100		100		ns
Repeated start condition setup time	$t_{(SUSTA)}$	100		100		ns
STOP condition setup time	$t_{(SUSTO)}$	100		100		ns
Data hold time	$t_{(HDDAT)}$	10	900	10	100	ns
Data setup time	$t_{(SUDAT)}$	100		20		ns
SCL clock low period	$t_{(LOW)}$	1300		200		ns
SCL clock high period	$t_{(HIGH)}$	600		60		ns
Data fall time	$t_F$		300		80	ns
Clock fall time	$t_F$		300		40	ns
Clock rise time	$t_R$		300		40	ns
Clock/data rise time for $SCLK \leq 100kHz$	$t_R$		1000		—	ns

(1) Values based on a statistical analysis of a one-time sample of devices. Minimum and maximum values are specified by design, but not production tested.

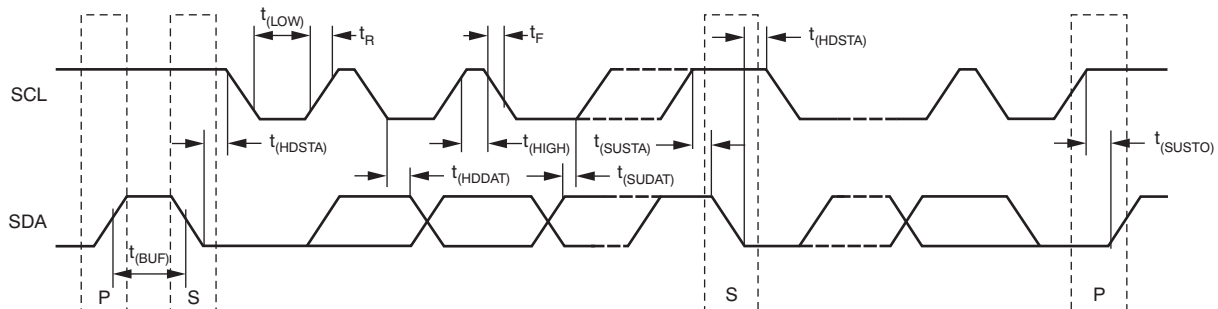
### 8.5.3.4 SMBus Alert Response

When SMBus Alerts are latched, the INA260 is designed to respond to the SMBus Alert Response address. The SMBus Alert Response provides a quick fault identification for simple slave devices. When an Alert occurs, the master can broadcast the Alert Response slave address (0001 100) with the Read/Write bit set high. Following this Alert Response, any slave device that generates an alert identifies itself by acknowledging the Alert Response and sending its address on the bus.

The Alert Response can activate several different slave devices simultaneously, similar to the I<sup>2</sup>C General Call. If more than one slave attempts to respond, bus arbitration rules apply and the device with the lowest address will win and be serviced first. The losing devices do not generate an Acknowledge and continues to hold the Alert line low until the interrupt is cleared. The winning device responds with its address and releases the SMBus alert line. Even though the INA260 releases the SMBus line the internal error flags are not cleared until done so by the host.

## 8.6 Register Maps

The INA260 uses a bank of registers for holding configuration settings, measurement results, minimum/maximum limits, and status information. 表 4 summarizes the device registers; see the [Functional Block Diagram](#) section for an illustration of the registers.

表 4. Register Set Summary

POINTER ADDRESS	REGISTER NAME	FUNCTION	POWER-ON RESET		TYPE <sup>(1)</sup>
			BINARY	HEX	
00h	Configuration Register	All-register reset, shunt voltage and bus voltage ADC conversion times and averaging, operating mode.	01100001 00100111	6127	R/ $\overline{W}$
01h	Current Register	Contains the value of the current flowing through the shunt resistor.	00000000 00000000	0000	R
02h	Bus Voltage Register	Bus voltage measurement data.	00000000 00000000	0000	R
03h	Power Register	Contains the value of the calculated power being delivered to the load.	00000000 00000000	0000	R
06h	Mask/Enable Register	Alert configuration and Conversion Ready flag.	00000000 00000000	0000	R/ $\overline{W}$
07h	Alert Limit Register	Contains the limit value to compare to the selected Alert function.	00000000 00000000	0000	R/ $\overline{W}$
FEh	Manufacturer ID Register	Contains unique manufacturer identification number.	0101010001001001	5449	R
FFh	Die ID Register	Contains unique die identification number.	0010001001110000	2270	R

(1) Type: R = Read-Only, R/ $\overline{W}$  = Read/Write.

### 8.6.1 Configuration Register (00h) (Read/Write)

The Configuration Register settings control the operating modes for the device. This register controls the conversion time settings for both shunt current and bus voltage measurements as well as the averaging mode used. The operating mode that controls what signals are selected to be measured is also programmed in the Configuration Register.

The Configuration Register can be read from at any time without impacting or affecting the device settings or a conversion in progress. Writing to the Configuration Register halts any conversion in progress until the write sequence is completed resulting in a new conversion starting based on the new contents of the Configuration Register (00h). This halt prevents any uncertainty in the conditions used for the next completed conversion.

图 30. Configuration Register (00h) (Read/Write)

15		14		13		12		11		10		9		8	
RST		—		—		—		AVG2		AVG1		AVG0		VBUSCT2	
0		1		1		0		0		0		0		1	
R/W				R						R/W					
7		6		5		4		3		2		1		0	
VBUSCT1		VBUSCT0		ISHCT2		ISHCT1		ISHCT0		MODE3		MODE2		MODE1	
0		0		1		0		0		1		1		1	
										R/W					

LEGEND: R/W = Read/Write; R = Read only; -n = value after reset

表 5. Configuration Register Field Descriptions

Bit	Field	Type	Reset	Description
15	RST	R/W	0	Reset Bit Setting this bit to '1' generates a system reset that is the same as power-on reset. Resets all registers to default values; this bit self-clears.
14–12	—	R	110	
11–9	AVG	R/W	000	Averaging Mode Determines the number of samples that are collected and averaged. The following shows all the AVG bit settings and related number of averages for each bit setting. AVG2 = 0, AVG1 = 0, AVG0 = 0, number of averages = 1 <sup>(1)</sup> AVG2 = 0, AVG1 = 0, AVG0 = 1, number of averages = 4 AVG2 = 0, AVG1 = 1, AVG0 = 0, number of averages = 16 AVG2 = 0, AVG1 = 1, AVG0 = 1, number of averages = 64 AVG2 = 1, AVG1 = 0, AVG0 = 0, number of averages = 128 AVG2 = 1, AVG1 = 0, AVG0 = 1, number of averages = 256 AVG2 = 1, AVG1 = 1, AVG0 = 0, number of averages = 512 AVG2 = 1, AVG1 = 1, AVG0 = 1, number of averages = 1024
8–6	VBUSCT	R/W	100	Bus Voltage Conversion Time Sets the conversion time for the bus voltage measurement. The following shows the VBUSCT bit options and related conversion times for each bit setting. VBUSCT2 = 0, VBUSCT1 = 0, VBUSCT0 = 0, conversion time = 140 μs VBUSCT2 = 0, VBUSCT1 = 0, VBUSCT0 = 1, conversion time = 204 μs VBUSCT2 = 0, VBUSCT1 = 1, VBUSCT0 = 0, conversion time = 332 μs VBUSCT2 = 0, VBUSCT1 = 1, VBUSCT0 = 1, conversion time = 588 μs VBUSCT2 = 1, VBUSCT1 = 0, VBUSCT0 = 0, conversion time = 1.1 ms <sup>(1)</sup> VBUSCT2 = 1, VBUSCT1 = 0, VBUSCT0 = 1, conversion time = 2.116 ms VBUSCT2 = 1, VBUSCT1 = 1, VBUSCT0 = 0, conversion time = 4.156 ms VBUSCT2 = 1, VBUSCT1 = 1, VBUSCT0 = 1, conversion time = 8.244 ms
5–3	ISHCT	R/W	100	Shunt Current Conversion Time The following shows the ISHCT bit options and related conversion times for each bit setting. ISHCT2 = 0, ISHCT1 = 0, ISHCT0 = 0, conversion time = 140 μs ISHCT2 = 0, ISHCT1 = 0, ISHCT0 = 1, conversion time = 204 μs ISHCT2 = 0, ISHCT1 = 1, ISHCT0 = 0, conversion time = 332 μs ISHCT2 = 0, ISHCT1 = 1, ISHCT0 = 1, conversion time = 588 μs ISHCT2 = 1, ISHCT1 = 0, ISHCT0 = 0, conversion time = 1.1 ms <sup>(1)</sup> ISHCT2 = 1, ISHCT1 = 0, ISHCT0 = 1, conversion time = 2.116 ms ISHCT2 = 1, ISHCT1 = 1, ISHCT0 = 0, conversion time = 4.156 ms ISHCT2 = 1, ISHCT1 = 1, ISHCT0 = 1, conversion time = 8.244 ms
2–0	MODE	R/W	111	Operating Mode Selects continuous, triggered, or power-down mode of operation. These bits default to continuous shunt and bus measurement mode. The following shows mode settings. MODE2 = 0, MODE1 = 0, MODE0 = 0, mode = Power-Down (or Shutdown) MODE2 = 0, MODE1 = 0, MODE0 = 1, mode = Shunt Current, Triggered MODE2 = 0, MODE1 = 1, MODE0 = 0, mode = Bus Voltage, Triggered MODE2 = 0, MODE1 = 1, MODE0 = 1, mode = Shunt Current and Bus Voltage, Triggered MODE2 = 1, MODE1 = 0, MODE0 = 0, mode = Power-Down (or Shutdown) MODE2 = 1, MODE1 = 0, MODE0 = 1, mode = Shunt Current, Continuous MODE2 = 1, MODE1 = 1, MODE0 = 0, mode = Bus Voltage, Continuous MODE2 = 1, MODE1 = 1, MODE0 = 1, mode = Shunt Current and Bus Voltage, Continuous <sup>(1)</sup>

(1) These values are default.

### 8.6.2 Current Register (01h) (Read-Only)

The value in the current register is represented in two's complement format to support negative current values. The LSB size for the current register is set to 1.25 mA. If averaging is enabled, this register will report the averaged value.

**图 31. Current Register (01h) (Read-Only)**

15	14	13	12	11	10	9	8
CSIGN	CD14	CD13	CD12	CD11	CD10	CD9	CD8
0	0	0	0	0	0	0	0
R							
7	6	5	4	3	2	1	0
CD7	CD6	CD5	CD4	CD3	CD2	CD1	CD0
0	0	0	0	0	0	0	0
R							

LEGEND: R/ $\overline{W}$  = Read/Write; R = Read only; -n = value after reset

### 8.6.3 Bus Voltage Register (02h) (Read-Only)

The Bus Voltage Register stores the most recent bus voltage reading, VBUS.

If averaging is enabled, this register reports the averaged value.

Full-scale range = 40.96 V (decimal = 32767); LSB = 1.25 mV.

**图 32. Bus Voltage Register (02h) (Read-Only)**

15 <sup>(1)</sup>	14	13	12	11	10	9	8
—	BD14	BD13	BD12	BD11	BD10	BD9	BD8
0	0	0	0	0	0	0	0
R							
7	6	5	4	3	2	1	0
BD7	BD6	BD5	BD4	BD3	BD2	BD1	BD0
0	0	0	0	0	0	0	0
R							

LEGEND: R/ $\overline{W}$  = Read/Write; R = Read only; -n = value after reset

(1) Bit 15 is always zero because bus voltage can only be positive.

### 8.6.4 Power Register (03h) (Read-Only)

If averaging is enabled, this register reports the averaged value.

The Power Register LSB is fixed to 10 mW.

The Power Register records power in Watts by multiplying the decimal values of the Current Register with the decimal value of the Bus Voltage Register. Values stored in the power register will always be positive regardless of the direction of current flow. The maximum value that can be returned by the power register is A3D7h or 419.43 W.

**图 33. Power Register (03h) (Read-Only)**

15	14	13	12	11	10	9	8
PD15	PD14	PD13	PD12	PD11	PD10	PD9	PD8
0	0	0	0	0	0	0	0
R							
7	6	5	4	3	2	1	0
PD7	PD6	PD5	PD4	PD3	PD2	PD1	PD0
0	0	0	0	0	0	0	0
R							

LEGEND: R/ $\overline{W}$  = Read/Write; R = Read only; -n = value after reset

### 8.6.5 Mask/Enable Register (06h) (Read/Write)

The Mask/Enable Register selects the function that is enabled to control the ALERT pin as well as how that pin functions. If multiple functions are enabled, the highest significant bit position Alert Function (D15-D11) takes priority and responds to the Alert Limit Register.

**图 34. Mask/Enable Register (06h) (Read/Write)**

15	14	13	12	11	10	9	8
OCL	UCL	BOL	BUL	POL	CNVR	—	—
0	0	0	0	0	0	0	0
R $\bar{W}$						R	
7	6	5	4	3	2	1	0
—	—	—	AFF	CVRF	OVF	APOL	LEN
0	0	0	0	0	0	0	0
R						R $\bar{W}$	

LEGEND: R $\bar{W}$  = Read/Write; R = Read only; -n = value after reset

**表 6. Mask/Enable Register Field Descriptions**

Bit	Field	Type	Reset	Description
15	OCL	R $\bar{W}$	0	Over Current Limit Setting this bit high configures the ALERT pin to be asserted if the current measurement following a conversion exceeds the value programmed in the Alert Limit Register.
14	UCL	R $\bar{W}$	0	Under Current Limit Setting this bit high configures the ALERT pin to be asserted if the current measurement following a conversion drops below the value programmed in the Alert Limit Register.
13	BOL	R $\bar{W}$	0	Bus Voltage Over-Voltage Setting this bit high configures the ALERT pin to be asserted if the bus voltage measurement following a conversion exceeds the value programmed in the Alert Limit Register.
12	BUL	R $\bar{W}$	0	Bus Voltage Under-Voltage Setting this bit high configures the ALERT pin to be asserted if the bus voltage measurement following a conversion drops below the value programmed in the Alert Limit Register.
11	POL	R $\bar{W}$	0	Power Over-Limit Setting this bit high configures the ALERT pin to be asserted if the Power calculation made following a bus voltage measurement exceeds the value programmed in the Alert Limit Register.
10	CNVR	R $\bar{W}$	0	Conversion Ready Setting this bit high configures the ALERT pin to be asserted when the Conversion Ready Flag, Bit 3, is asserted indicating that the device is ready for the next conversion.
9–5	—	R	00000	Not used.
4	AFF	R	0	Alert Function Flag While only one Alert Function can be monitored at the ALERT pin at a time, the Conversion Ready can also be enabled to assert the ALERT pin. Reading the Alert Function Flag following an alert allows the user to determine if the Alert Function was the source of the Alert.  When the Alert Latch Enable bit is set to Latch mode, the Alert Function Flag bit clears only when the Mask/Enable Register is read. When the Alert Latch Enable bit is set to Transparent mode, the Alert Function Flag bit is cleared following the next conversion that does not result in an Alert condition.
3	CVRF	R	0	Conversion Ready Although the device can be read at any time, and the data from the last conversion is available, the Conversion Ready Flag bit is provided to help coordinate one-shot or triggered conversions. The Conversion Ready Flag bit is set after all conversions, averaging, and multiplications are complete. Conversion Ready Flag bit clears under the following conditions: 1.) Writing to the Configuration Register (except for Power-Down selection) 2.) Reading the Mask/Enable Register

**表 6. Mask/Enable Register Field Descriptions (接下页)**

Bit	Field	Type	Reset	Description
2	OVF	R	0	Math Overflow Flag This bit is set to '1' if an arithmetic operation resulted in an overflow error. It indicates that power data may have exceeded the maximum reportable value of 419.43 W.
1	APOL	R $\overline{W}$	0	Alert Polarity bit 1 = Inverted (active-high open collector) 0 = Normal (active-low open collector) (default)
0	LEN	R $\overline{W}$	0	Alert Latch Enable; configures the latching feature of the ALERT pin and Alert Flag bits. 1 = Latch enabled 0 = Transparent (default)  When the Alert Latch Enable bit is set to Transparent mode, the ALERT pin and Flag bit resets to the idle states when the fault has been cleared. When the Alert Latch Enable bit is set to Latch mode, the ALERT pin and Alert Flag bit remains active following a fault until the Mask/Enable Register has been read.

### 8.6.6 Alert Limit Register (07h) (Read/Write)

The Alert Limit Register contains the value used to compare to the register selected in the Mask/Enable Register to determine if a limit has been exceeded. The format for this register will match the format of the register that is selected for comparison.

**图 35. Alert Limit Register (07h) (Read/Write)**

15	14	13	12	11	10	9	8
AUL15	AUL14	AUL13	AUL12	AUL11	AUL10	AUL9	AUL8
0	0	0	0	0	0	0	0
R $\overline{W}$							
7	6	5	4	3	2	1	0
AUL7	AUL6	AUL5	AUL4	AUL3	AUL2	AUL1	AUL0
0	0	0	0	0	0	0	0
R $\overline{W}$							

LEGEND: R $\overline{W}$  = Read/Write; R = Read only; -n = value after reset

### 8.6.7 Manufacturer ID Register (FEh) (Read-Only)

The Manufacturer ID Register stores a unique identification number for the manufacturer.

**图 36. Manufacturer ID Register (FEh) (Read-Only)**

15	14	13	12	11	10	9	8
ID15	ID14	ID13	ID12	ID11	ID10	ID9	ID8
0	1	0	1	0	1	0	0
R							
7	6	5	4	3	2	1	0
ID7	ID6	ID5	ID4	ID3	ID2	ID1	ID0
0	1	0	0	1	0	0	1
R							

LEGEND: R $\overline{W}$  = Read/Write; R = Read only; -n = value after reset

**表 7. Manufacturer ID Register Field Descriptions**

Bit	Field	Type	Reset	Description
15–0	ID	R	5449h /TI (ascii)	Manufacturer ID Stores the manufacturer identification bits

### 8.6.8 Die ID Register (FFh) (Read-Only)

The Die ID Register stores a unique identification number and the revision ID for the die.

**图 37. Die ID Register (FFh) (Read-Only)**

15	14	13	12	11	10	9	8
DID11	DID10	DID9	DID8	DID7	DID6	DID5	DID4
0	0	1	0	0	0	1	0
R							
7	6	5	4	3	2	1	0
DID3	DID2	DID1	DID0	RID3	RID2	RID1	RID0
0	1	1	1	0	0	0	0
R							

LEGEND: R/ $\overline{W}$  = Read/Write; R = Read only; -n = value after reset

**表 8. Die ID Register Field Descriptions**

Bit	Field	Type	Reset	Description
15–4	DID	R	227h	Device ID Stores the device identification bits.
3–0	RID	R	0h	Die Revision ID Stores the device revision identification bits.

## 9 Application and Implementation

### 注

Information in the following applications sections is not part of the TI component specification, and TI does not warrant its accuracy or completeness. TI's customers are responsible for determining suitability of components for their purposes. Validate and test the design implementation to confirm system functionality.

### 9.1 Application Information

The INA260 is a current shunt and power monitor with an I<sup>2</sup>C-compatible interface. The device monitors both a shunt current and bus supply voltage. The internally calibrated integrated current sense resistor combined with an internal multiplier, enable direct readouts of current in amperes and power in watts.

### 9.2 Typical Application



图 38. Typical Circuit Configuration, INA260

#### 9.2.1 Design Requirements

The INA260 measures current and the bus supply voltage and calculates power. It comes with alert capability where the ALERT pin can be programmed to respond to a user-defined event or to a conversion ready notification. This design illustrates the ability of the ALERT pin to respond to a set threshold.

## Typical Application (接下页)

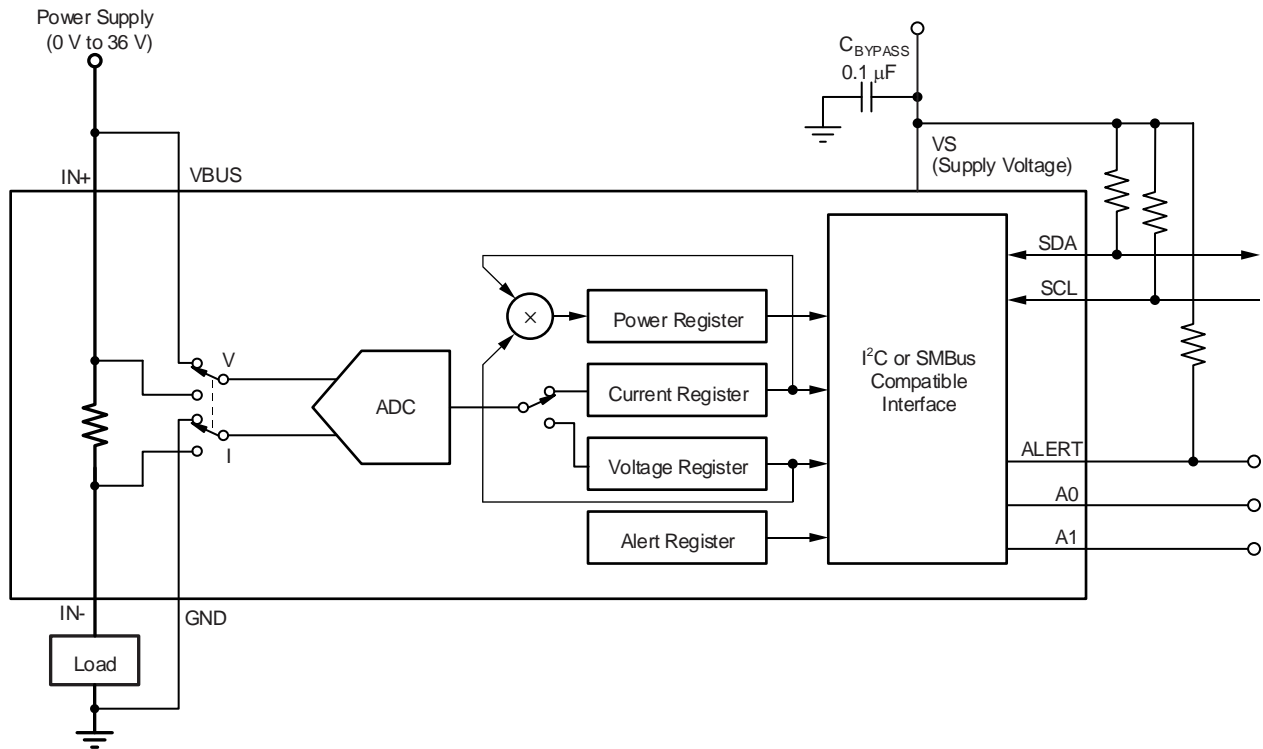
### 9.2.2 Detailed Design Procedure

The ALERT pin can be configured to respond to one of the five alert functions described in the [ALERT Pin](#) section. The ALERT pin must be pulled up to the VS pin voltage through an external pullup resistor. The configuration register is set based on the required conversion time and averaging. The Mask/Enable Register is set to identify the required alert function and the Alert Limit Register is set to the limit value used for comparison.

### 9.2.3 Application Curves

图 40 shows the ALERT pin response to a bus over voltage limit of 5.5 V for a conversion time ( $t_{CT}$ ) of 1.1 ms and averaging set to 1. 图 39 shows the response for the same limit but with the conversion time reduced to 140  $\mu$ s. For the scope shots shown in these figures, persistence was enabled on the ALERT channel. This shows how the ALERT response time can vary depending on when the fault condition occurs relative to the internal ADC clock of the INA260. For fault conditions that are just exceeding the limit threshold the response time for the ALERT pin can vary from 1 to 2 conversion cycles. As mentioned, the variation is due to the timing on when the fault event occurs relative to the start time of the internal ADC conversion cycle. For fault events that greatly exceed the limit threshold it is possible for the alert to respond in less than one conversion cycle. This is because it takes fewer samples for the average to exceed the limit threshold value.



表 9. Configuration Register (00h) Settings for 图 39 (Value = 6006h)

BIT #	15	14	13	12	11	10	9	8	7	6	5	4	3	2	1	0
BIT NAME	RST	—	—	—	AVG2	AVG1	AVG0	VBUSC T2	VBUSC T1	VBUSC T0	ISHCT2	ISHCT1	ISHCT0	MODE3	MODE2	MODE1
POR VALUE	0	1	1	0	0	0	0	0	0	0	0	0	0	1	1	0

表 10. Configuration Register (00h) Settings for 图 40 (Value = 6126h)

BIT #	15	14	13	12	11	10	9	8	7	6	5	4	3	2	1	0
BIT NAME	RST	—	—	—	AVG2	AVG1	AVG0	VBUSC T2	VBUSC T1	VBUSC T0	ISHCT2	ISHCT1	ISHCT0	MODE3	MODE2	MODE1
POR VALUE	0	1	1	0	0	0	0	1	0	0	1	0	0	1	1	0

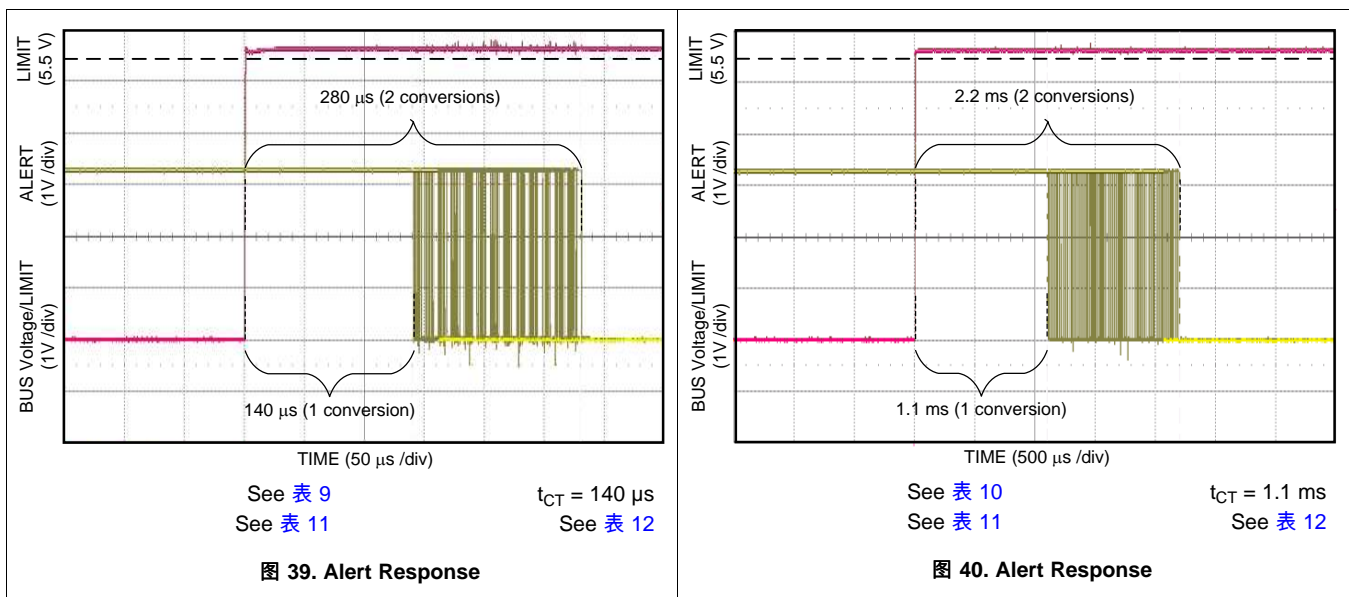
表 11. Mask/Enable Register (06h) Settings for 图 39 and 图 40 (Value = 2008h)

BIT #	15	14	13	12	11	10	9	8	7	6	5	4	3	2	1	0
BIT NAME	OCL	UCL	BOL	BUL	POL	CNVR	—	—	—	—	—	AFF	CVRF	OVF	APOL	LEN
POR VALUE	0	0	1	0	0	0	0	0	0	0	0	0	1	0	0	0

表 12. Alert Limit Register (07h) Settings for 图 39 and 图 40 (Value = 1130h)

BIT #	15	14	13	12	11	10	9	8	7	6	5	4	3	2	1	0
BIT NAME	AUL15	AUL14	AUL13	AUL12	AUL11	AUL10	AUL9	AUL8	AUL7	AUL6	AUL5	AUL4	AUL3	AUL2	AUL1	AUL0
POR VALUE	0	0	0	1	0	0	0	1	0	0	1	1	0	0	0	0

## 10 Power Supply Recommendations

The input circuitry of the device can accurately measure signals on common-mode voltages beyond its power supply voltage,  $V_{VS}$ . For example, the voltage applied to the power supply terminal (VS) can be 5 V, whereas the load power-supply voltage being monitored (the common-mode voltage) can be as high as 36 V. Note also that the device can withstand the full 0-V to 36-V range at the input terminals, regardless of whether the device has power applied or not.

Place the required power-supply bypass capacitors as close as possible to the supply and ground terminals of the device. A typical value for this supply bypass capacitor is 0.1  $\mu$ F. Applications with noisy or high-impedance power supplies may require additional decoupling capacitors to reject power-supply noise.

## 11 Layout

### 11.1 Layout Guidelines

Connections to the internal shunt resistor should be connected directly into and out of the shunt resistor pins to encourage uniform current flow through the device. The trace width should be sized correctly to handle the desired current flow. Place the power-supply bypass capacitor as close as possible to the supply and ground pins. Use of multiple vias to connect the device ground to the bypass capacitor grounds is recommended if there is not direct connection on the top layer.

### 11.2 Layout Example

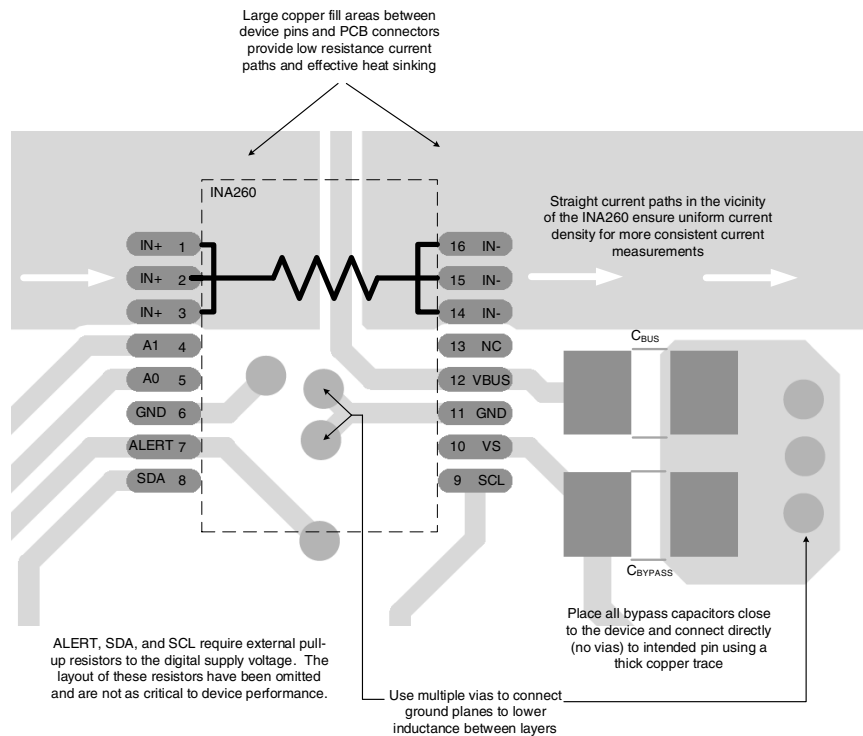

NOTE: Connect the VBUS pin to the power supply rail.

图 41. INA260 Layout Example

## 12 器件和文档支持

### 12.1 器件支持

#### 12.1.1 Third-Party Products Disclaimer

TI'S PUBLICATION OF INFORMATION REGARDING THIRD-PARTY PRODUCTS OR SERVICES DOES NOT CONSTITUTE AN ENDORSEMENT REGARDING THE SUITABILITY OF SUCH PRODUCTS OR SERVICES OR A WARRANTY, REPRESENTATION OR ENDORSEMENT OF SUCH PRODUCTS OR SERVICES, EITHER ALONE OR IN COMBINATION WITH ANY TI PRODUCT OR SERVICE.

### 12.2 文档支持

#### 12.2.1 相关文档

相关文档请参见以下部分:

《[INA260EVM 评估板和软件教程](#)》用户指南 (文献编号: SBOU113)

#### 12.3 接收文档更新通知

如需接收文档更新通知, 请访问 [www.ti.com.cn](http://www.ti.com.cn) 网站上的器件产品文件夹。点击右上角的提醒我 (Alert me) 注册后, 即可每周定期收到已更改的产品信息。有关更改的详细信息, 请查阅已修订文档中包含的修订历史记录。

#### 12.4 社区资源

The following links connect to TI community resources. Linked contents are provided "AS IS" by the respective contributors. They do not constitute TI specifications and do not necessarily reflect TI's views; see TI's [Terms of Use](#).

**TI E2E™ Online Community** *TI's Engineer-to-Engineer (E2E) Community*. Created to foster collaboration among engineers. At [e2e.ti.com](http://e2e.ti.com), you can ask questions, share knowledge, explore ideas and help solve problems with fellow engineers.

**Design Support** *TI's Design Support* Quickly find helpful E2E forums along with design support tools and contact information for technical support.

#### 12.5 商标

E2E is a trademark of Texas Instruments.

SMBus is a trademark of Intel Corporation.

All other trademarks are the property of their respective owners.

#### 12.6 静电放电警告



ESD 可能会损坏该集成电路。德州仪器 (TI) 建议通过适当的预防措施处理所有集成电路。如果不遵守正确的处理措施和安装程序, 可能会损坏集成电路。

ESD 的损坏小至导致微小的性能降级, 大至整个器件故障。精密的集成电路可能更容易受到损坏, 这是因为非常细微的参数更改都可能会导致器件与其发布的规格不相符。

#### 12.7 Glossary

[SLYZ022](#) — *TI Glossary*.

This glossary lists and explains terms, acronyms, and definitions.

## 13 机械、封装和可订购信息

以下页中包括机械、封装和可订购信息。这些信息是针对指定器件可提供的最新数据。这些数据会在无通知且不对本文档进行修订的情况下发生改变。欲获得该数据表的浏览器版本, 请查阅左侧的导航栏。

## 重要声明

德州仪器(TI)及其下属子公司有权根据 JESD46 最新标准,对所提供的产品和服务进行更正、修改、增强、改进或其它更改,并有权根据 JESD48 最新标准中止提供任何产品和服务。客户在下订单前应获取最新的相关信息,并验证这些信息是否完整且是最新的。所有产品的销售都遵循在订单确认时所提供的TI 销售条款与条件。

TI 保证其所销售的组件的性能符合产品销售时 TI 半导体产品销售条件与条款的适用规范。仅在 TI 保证的范围内,且 TI 认为有必要时才会使用测试或其它质量控制技术。除非适用法律做出了硬性规定,否则没有必要对每种组件的所有参数进行测试。

TI 对应用帮助或客户产品设计不承担任何义务。客户应对其使用 TI 组件的产品和应用自行负责。为尽量减小与客户产品和应用相关的风险,客户应提供充分的设计与操作安全措施。

TI 不对任何 TI 专利权、版权、屏蔽作品权或其它与使用了 TI 组件或服务的组合设备、机器或流程相关的 TI 知识产权中授予的直接或隐含权限作出任何保证或解释。TI 所发布的与第三方产品或服务有关的信息,不能构成从 TI 获得使用这些产品或服务的许可、授权、或认可。使用此类信息可能需要获得第三方的专利权或其它知识产权方面的许可,或是 TI 的专利权或其它知识产权方面的许可。

对于 TI 的产品手册或数据表中 TI 信息的重要部分,仅在没有对内容进行任何篡改且带有相关授权、条件、限制和声明的情况下才允许进行复制。TI 对此类篡改过的文件不承担任何责任或义务。复制第三方的信息可能需要服从额外的限制条件。

在转售 TI 组件或服务时,如果对该组件或服务参数的陈述与 TI 标明的参数相比存在差异或虚假成分,则会失去相关 TI 组件或服务的所有明示或暗示授权,且这是不正当的、欺诈性商业行为。TI 对任何此类虚假陈述均不承担任何责任或义务。

客户认可并同意,尽管任何应用相关信息或支持仍可能由 TI 提供,但他们将独立负责满足与其产品及其在应用中使用的 TI 产品相关的所有法律、法规和安全相关要求。客户声明并同意,他们具备制定与实施安全措施所需的全部专业技术和知识,可预见故障的危险后果、监测故障及其后果、降低有可能造成人身伤害的故障的发生机率并采取适当的补救措施。客户将全额赔偿因在此类安全关键应用中使用任何 TI 组件而对 TI 及其代理造成的任何损失。

在某些场合中,为了推进安全相关应用有可能对 TI 组件进行特别的促销。TI 的目标是利用此类组件帮助客户设计和创立其特有的可满足适用的功能安全性标准和要求的终端产品解决方案。尽管如此,此类组件仍然服从这些条款。

TI 组件未获得用于 FDA Class III (或类似的生命攸关医疗设备)的授权许可,除非各方授权官员已经达成了专门管控此类使用的特别协议。

只有那些 TI 特别注明属于军用等级或“增强型塑料”的 TI 组件才是设计或专门用于军事/航空应用或环境的。购买者认可并同意,对并非指定面向军事或航空航天用途的 TI 组件进行军事或航空航天方面的应用,其风险由客户单独承担,并且由客户独立负责满足与此类使用相关的所有法律和法规要求。

TI 已明确指定符合 ISO/TS16949 要求的产品,这些产品主要用于汽车。在任何情况下,因使用非指定产品而无法达到 ISO/TS16949 要求, TI 不承担任何责任。

	产品		应用
数字音频	<a href="http://www.ti.com.cn/audio">www.ti.com.cn/audio</a>	通信与电信	<a href="http://www.ti.com.cn/telecom">www.ti.com.cn/telecom</a>
放大器和线性器件	<a href="http://www.ti.com.cn/amplifiers">www.ti.com.cn/amplifiers</a>	计算机及周边	<a href="http://www.ti.com.cn/computer">www.ti.com.cn/computer</a>
数据转换器	<a href="http://www.ti.com.cn/dataconverters">www.ti.com.cn/dataconverters</a>	消费电子	<a href="http://www.ti.com.cn/consumer-apps">www.ti.com.cn/consumer-apps</a>
DLP® 产品	<a href="http://www.dlp.com">www.dlp.com</a>	能源	<a href="http://www.ti.com.cn/energy">www.ti.com.cn/energy</a>
DSP - 数字信号处理器	<a href="http://www.ti.com.cn/dsp">www.ti.com.cn/dsp</a>	工业应用	<a href="http://www.ti.com.cn/industrial">www.ti.com.cn/industrial</a>
时钟和计时器	<a href="http://www.ti.com.cn/clockandtimers">www.ti.com.cn/clockandtimers</a>	医疗电子	<a href="http://www.ti.com.cn/medical">www.ti.com.cn/medical</a>
接口	<a href="http://www.ti.com.cn/interface">www.ti.com.cn/interface</a>	安防应用	<a href="http://www.ti.com.cn/security">www.ti.com.cn/security</a>
逻辑	<a href="http://www.ti.com.cn/logic">www.ti.com.cn/logic</a>	汽车电子	<a href="http://www.ti.com.cn/automotive">www.ti.com.cn/automotive</a>
电源管理	<a href="http://www.ti.com.cn/power">www.ti.com.cn/power</a>	视频和影像	<a href="http://www.ti.com.cn/video">www.ti.com.cn/video</a>
微控制器 (MCU)	<a href="http://www.ti.com.cn/microcontrollers">www.ti.com.cn/microcontrollers</a>		
RFID 系统	<a href="http://www.ti.com.cn/rfidsys">www.ti.com.cn/rfidsys</a>		
OMAP应用处理器	<a href="http://www.ti.com/omap">www.ti.com/omap</a>		
无线连通性	<a href="http://www.ti.com.cn/wirelessconnectivity">www.ti.com.cn/wirelessconnectivity</a>	德州仪器在线技术支持社区	<a href="http://www.deyisupport.com">www.deyisupport.com</a>

邮寄地址: 上海市浦东新区世纪大道1568号, 中建大厦32楼邮政编码: 200122  
Copyright © 2016, 德州仪器半导体技术(上海)有限公司

**PACKAGING INFORMATION**

Orderable Device	Status (1)	Package Type	Package Drawing	Pins	Package Qty	Eco Plan (2)	Lead/Ball Finish (6)	MSL Peak Temp (3)	Op Temp (°C)	Device Marking (4/5)	Samples
INA260AIPW	ACTIVE	TSSOP	PW	16	90	Green (RoHS & no Sb/Br)	CU NIPDAU	Level-2-260C-1 YEAR	-40 to 125	I260AI	<a href="#">Samples</a>
INA260AIPWR	ACTIVE	TSSOP	PW	16	2000	Green (RoHS & no Sb/Br)	CU NIPDAU	Level-2-260C-1 YEAR	-40 to 125	I260AI	<a href="#">Samples</a>

(1) The marketing status values are defined as follows:

**ACTIVE:** Product device recommended for new designs.

**LIFEBUY:** TI has announced that the device will be discontinued, and a lifetime-buy period is in effect.

**NRND:** Not recommended for new designs. Device is in production to support existing customers, but TI does not recommend using this part in a new design.

**PREVIEW:** Device has been announced but is not in production. Samples may or may not be available.

**OBSELETE:** TI has discontinued the production of the device.

(2) Eco Plan - The planned eco-friendly classification: Pb-Free (RoHS), Pb-Free (RoHS Exempt), or Green (RoHS & no Sb/Br) - please check <http://www.ti.com/productcontent> for the latest availability information and additional product content details.

**TBD:** The Pb-Free/Green conversion plan has not been defined.

**Pb-Free (RoHS):** TI's terms "Lead-Free" or "Pb-Free" mean semiconductor products that are compatible with the current RoHS requirements for all 6 substances, including the requirement that lead not exceed 0.1% by weight in homogeneous materials. Where designed to be soldered at high temperatures, TI Pb-Free products are suitable for use in specified lead-free processes.

**Pb-Free (RoHS Exempt):** This component has a RoHS exemption for either 1) lead-based flip-chip solder bumps used between the die and package, or 2) lead-based die adhesive used between the die and leadframe. The component is otherwise considered Pb-Free (RoHS compatible) as defined above.

**Green (RoHS & no Sb/Br):** TI defines "Green" to mean Pb-Free (RoHS compatible), and free of Bromine (Br) and Antimony (Sb) based flame retardants (Br or Sb do not exceed 0.1% by weight in homogeneous material)

(3) MSL, Peak Temp. - The Moisture Sensitivity Level rating according to the JEDEC industry standard classifications, and peak solder temperature.

(4) There may be additional marking, which relates to the logo, the lot trace code information, or the environmental category on the device.

(5) Multiple Device Markings will be inside parentheses. Only one Device Marking contained in parentheses and separated by a "~" will appear on a device. If a line is indented then it is a continuation of the previous line and the two combined represent the entire Device Marking for that device.

(6) Lead/Ball Finish - Orderable Devices may have multiple material finish options. Finish options are separated by a vertical ruled line. Lead/Ball Finish values may wrap to two lines if the finish value exceeds the maximum column width.

**Important Information and Disclaimer:** The information provided on this page represents TI's knowledge and belief as of the date that it is provided. TI bases its knowledge and belief on information provided by third parties, and makes no representation or warranty as to the accuracy of such information. Efforts are underway to better integrate information from third parties. TI has taken and continues to take reasonable steps to provide representative and accurate information but may not have conducted destructive testing or chemical analysis on incoming materials and chemicals. TI and TI suppliers consider certain information to be proprietary, and thus CAS numbers and other limited information may not be available for release.

In no event shall TI's liability arising out of such information exceed the total purchase price of the TI part(s) at issue in this document sold by TI to Customer on an annual basis.

## TAPE AND REEL INFORMATION



### QUADRANT ASSIGNMENTS FOR PIN 1 ORIENTATION IN TAPE



\*All dimensions are nominal

Device	Package Type	Package Drawing	Pins	SPQ	Reel Diameter (mm)	Reel Width W1 (mm)	A0 (mm)	B0 (mm)	K0 (mm)	P1 (mm)	W (mm)	Pin1 Quadrant
INA260AIPWR	TSSOP	PW	16	2000	330.0	12.4	6.9	5.6	1.6	8.0	12.0	Q1

**TAPE AND REEL BOX DIMENSIONS**

\*All dimensions are nominal

Device	Package Type	Package Drawing	Pins	SPQ	Length (mm)	Width (mm)	Height (mm)
INA260AIPWR	TSSOP	PW	16	2000	367.0	367.0	35.0



4220204/A 02/2017

**NOTES:**

1. All linear dimensions are in millimeters. Any dimensions in parenthesis are for reference only. Dimensioning and tolerancing per ASME Y14.5M.
2. This drawing is subject to change without notice.
3. This dimension does not include mold flash, protrusions, or gate burrs. Mold flash, protrusions, or gate burrs shall not exceed 0.15 mm per side.
4. This dimension does not include interlead flash. Interlead flash shall not exceed 0.25 mm per side.
5. Reference JEDEC registration MO-153.

# EXAMPLE BOARD LAYOUT

PW0016A

TSSOP - 1.2 mm max height

SMALL OUTLINE PACKAGE



LAND PATTERN EXAMPLE  
EXPOSED METAL SHOWN  
SCALE: 10X



SOLDER MASK DETAILS

4220204/A 02/2017

NOTES: (continued)

- 6. Publication IPC-7351 may have alternate designs.
- 7. Solder mask tolerances between and around signal pads can vary based on board fabrication site.

# EXAMPLE STENCIL DESIGN

PW0016A

TSSOP - 1.2 mm max height

SMALL OUTLINE PACKAGE



SOLDER PASTE EXAMPLE  
BASED ON 0.125 mm THICK STENCIL  
SCALE: 10X

4220204/A 02/2017

NOTES: (continued)

8. Laser cutting apertures with trapezoidal walls and rounded corners may offer better paste release. IPC-7525 may have alternate design recommendations.
9. Board assembly site may have different recommendations for stencil design.

## 重要声明和免责声明

TI 均以“原样”提供技术性数据（包括数据表）、设计资源（包括参考设计）、应用或其他设计建议、网络工具、安全信息和其他资源，不保证其中不含任何瑕疵，且不做任何明示或暗示的担保，包括但不限于对适销性、适合某特定用途或不侵犯任何第三方知识产权的暗示担保。

所述资源可供专业开发人员应用TI 产品进行设计使用。您将对以下行为独自承担全部责任：(1) 针对您的应用选择合适的TI 产品；(2) 设计、验证并测试您的应用；(3) 确保您的应用满足相应标准以及任何其他安全、安保或其他要求。所述资源如有变更，恕不另行通知。TI 对您使用所述资源的授权仅限于开发资源所涉及TI 产品的相关应用。除此之外不得复制或展示所述资源，也不提供其它TI 或任何第三方的知识产权授权许可。如因使用所述资源而产生任何索赔、赔偿、成本、损失及债务等，TI 对此概不负责，并且您须赔偿由此对TI 及其代表造成的损害。

TI 所提供产品均受TI 的销售条款 (<http://www.ti.com.cn/zh-cn/legal/termsofsale.html>) 以及ti.com.cn上或随附TI产品提供的其他可适用条款的约束。TI提供所述资源并不扩展或以其他方式更改TI 针对TI 产品所发布的可适用的担保范围或担保免责声明。

邮寄地址：上海市浦东新区世纪大道 1568 号中建大厦 32 楼，邮政编码：200122  
Copyright © 2019 德州仪器半导体技术（上海）有限公司