



### WR90 High Power 4-Port Waveguide Circulator 1500MHz BW Between 8.2 – 12.4GHz



#### Features

- High power handling up to 500W CW.
- Wide band operation
- High isolation within operational band
- Low Insertion Loss
- Stable performance over temperature

#### Typical Applications

- Aerospace and military applications
- LMDS multi-carrier operation

#### Electrical Specifications, $T_A=25\text{ }^\circ\text{C}$

Parameter	Min.	Typ.	Max.	Units
Frequency Range	8.2-12.4 (8.5 to 10GHz Shown)			GHz
Bandwidth	500	1000	1500	MHz
Insertion Loss			0.30	dB
Isolation	23			dB
VSWR			1.18	:1
Power handling (CW)			500	W
Peak Power Handling	6KW (8% duty cycle)			
Rotation	Clockwise (Standard) Counter Clockwise (upon request)			
Bandwidth	1500MHz (8.5-10.5GHz as shown)			
Flange Type	COVER			
Flange Holes	Through			
External Body Finish	Body painted with gray / Black epoxy enamel			
Case Material	Aluminum Alloy			

WR90 High Power 4-Ports Waveguide Circulator 8.2 – 12.4GHz



### Environmental Specifications and Test Standards

Parameter	Standard	Description
Operational Temperature	MIL-STD-39016	-45°C~+75°C
Storage Temperature		-50°C~+125°C
Thermal Shock		1 Hour@ -45°C → 1 Hour @ +85°C (5 Cycles)
Random Vibration		Acceleration Spectral Density 6 (m/s) Total 92.6 RMS
Electrical & Temperature Burn In		Temperature +85°C for 72 Hours
Shock		1. Weight >20g, 50g half sine wave for 11ms, Speed variation 3.44m/s 2. Weight <=20g, 100g Half sine wave for 6ms, Speed variation 3.75m/s 3. Total 18 times (6 directions, 3 repetitions per direction).
Altitude		Standard: 30,000 Ft (Epoxy Sealed Controlled Environment) Optional: Hermetically Sealed (60,000 ft. 1.0 PSI min)
Hermetically Sealed (Optional)	MIL-STD-883	MIL-STD-883 (For Hermetically Sealed Units)

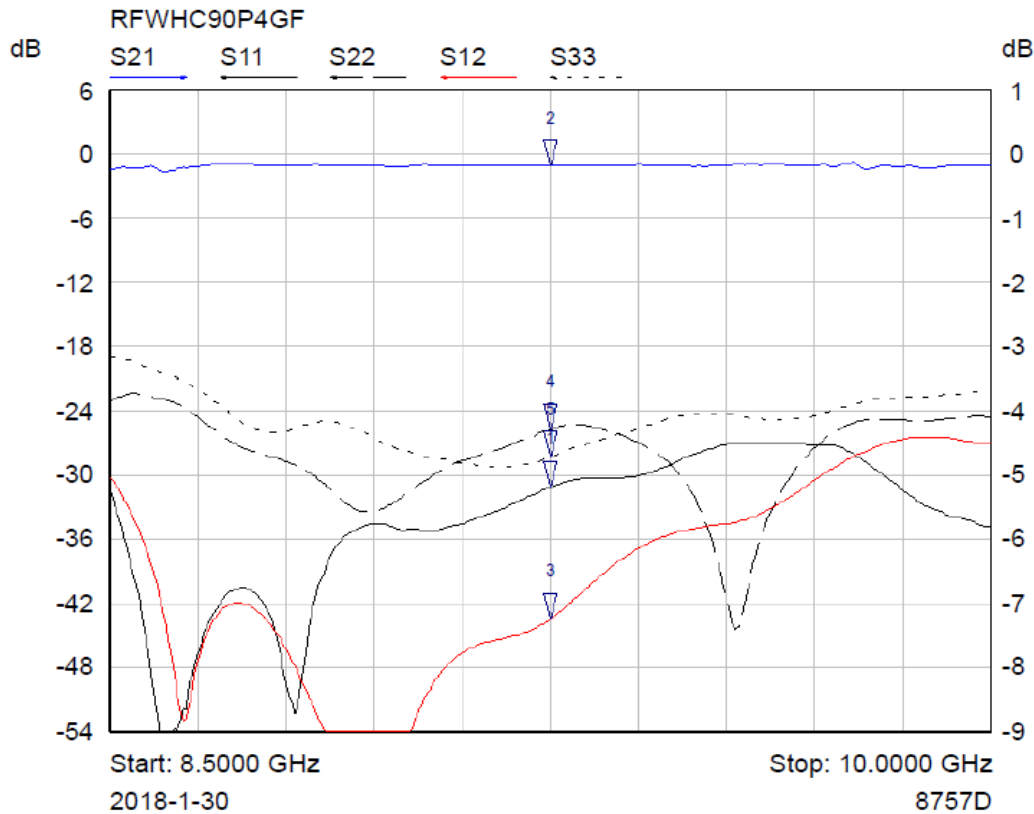

Mkr	Trace	X-Axis	Value	Notes
1	S11	9.2500 GHz	-31.12 dB	
2	S21	9.2500 GHz	-0.18 dB	
3	S12	9.2500 GHz	-43.47 dB	
4	S22	9.2500 GHz	-25.67 dB	
5	S33	9.2500 GHz	-28.29 dB	



### Outline Drawing:

All Dimensions in mm

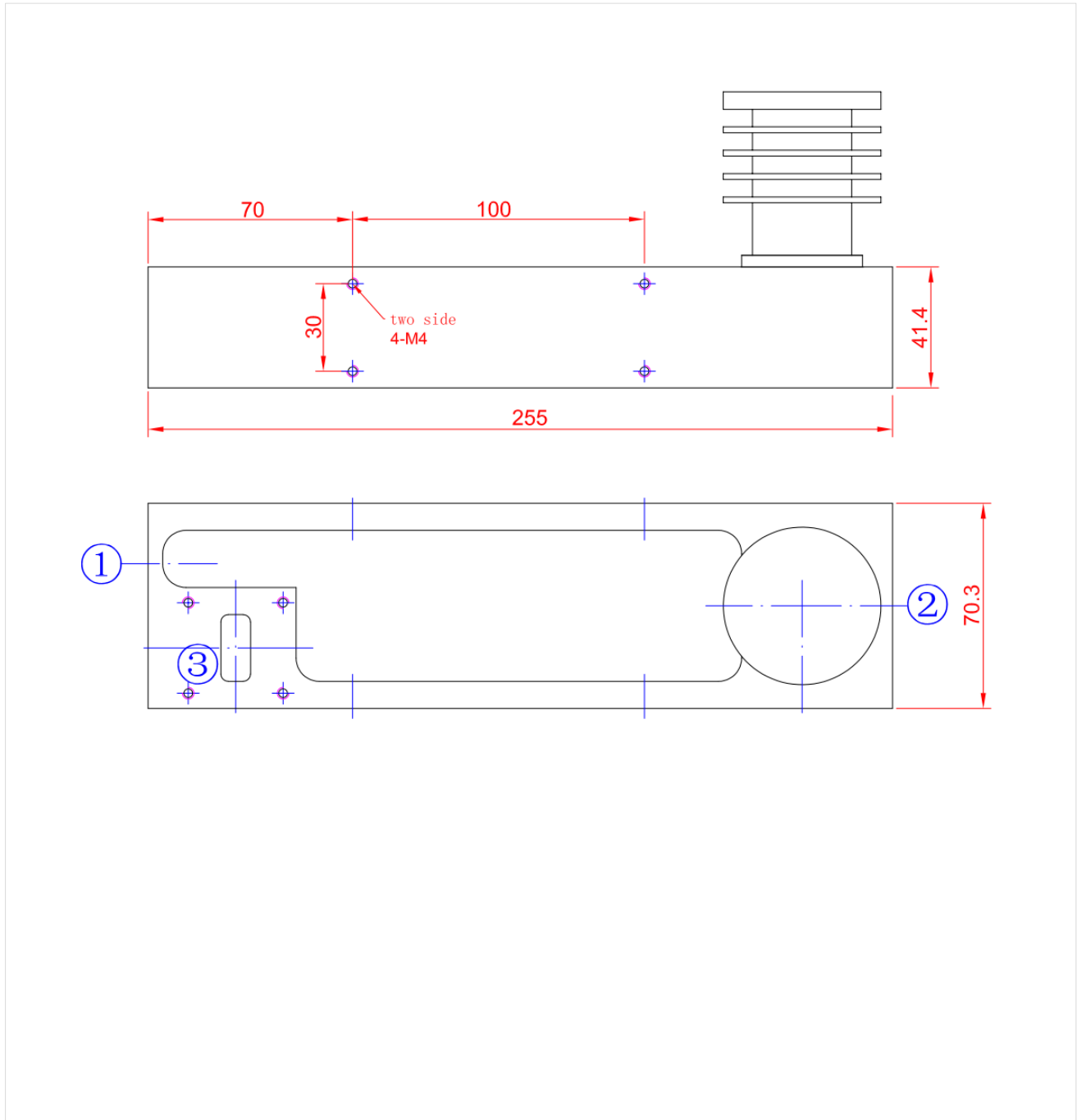

WR90 High Power 4-Ports Waveguide Circulator 8.2-12.4GHz

### Important Notice

The information contained herein is believed to be reliable. RF-Lambda makes no warranties regarding the information contained herein. RF-Lambda assumes no responsibility or liability whatsoever for any of the information contained herein. RF-Lambda assumes no responsibility or liability whatsoever for the use of the information contained herein. The information contained herein is provided "AS IS, WHERE IS" and with all faults, and the entire risk associated with such information is entirely with the user. All information contained herein is subject to change without notice. Customers should obtain and verify the latest relevant information before placing orders for RF-Lambda products. The information contained herein or any use of such information does not grant, explicitly or implicitly, to any party any patent rights, licenses, or any other intellectual property rights, whether with regard to such information itself or anything described by such information. RF-Lambda products are not warranted or authorized for use as critical components in medical, life-saving, or life sustaining applications, or other applications where a failure would reasonably be expected to cause severe personal injury or death.