



WR112 High Power Waveguide Circulator 7.05 – 10GHz



Note: Photo is for illustration Purpose Only.
Please refer to outline drawing.



Features

- High power handling up to 250W CW.
- Wide band operation
- High isolation within operational band
- Low Insertion Loss
- Stable performance over temperature

Typical Applications

- Aerospace and military applications
- LMDS multi-carrier operation

Electrical Specifications, $T_A=25\text{ }^\circ\text{C}$

Parameter	Min.	Typ.	Max.	Units
Frequency Range	7.05~10			GHz
Bandwidth	Full			
Insertion Loss			0.5	dB
Isolation	20			dB
VSWR			1.25	:1
Forward Power (CW)			250	W
Reverse Power (CW)			250	W
Peak Power Handling	4KW (8% duty cycle)			
Rotation	Clockwise (Standard) Counter Clockwise (Upon Request)			
Waveguide type	Rectangular Waveguide WR112			
Flange Type	UG138/U			
Case Material	Aluminum Alloy			

WR112 High Power Waveguide Circulator 7.05 – 10GHz



Environmental Specifications and Test Standards

Parameter	Standard	Description
Operational Temperature	MIL-STD-39016	-20°C~+60°C
Storage Temperature		-45°C~+125°C
Thermal Shock		1 Hour@ -45°C → 1 Hour @ +85°C (5 Cycles)
Random Vibration		Acceleration Spectral Density 6 (m/s) Total 92.6 RMS
Electrical & Temperature Burn In		Temperature +85°C for 72 Hours
Shock		1. Weight >20g, 50g half sine wave for 11ms, Speed variation 3.44m/s 2. Weight <=20g, 100g Half sine wave for 6ms, Speed variation 3.75m/s 3. Total 18 times (6 directions, 3 repetitions per direction).
Altitude		Standard: 30,000 Ft (Epoxy Sealed Controlled Environment) Optional: Hermetically Sealed (60,000 ft. 1.0 PSI min)
Hermetically Sealed (Optional)		MIL-STD-883

WR112 High Power Waveguide Circulator 7.05 – 10GHz



Outline Drawing:

All Dimensions in mm [inches]

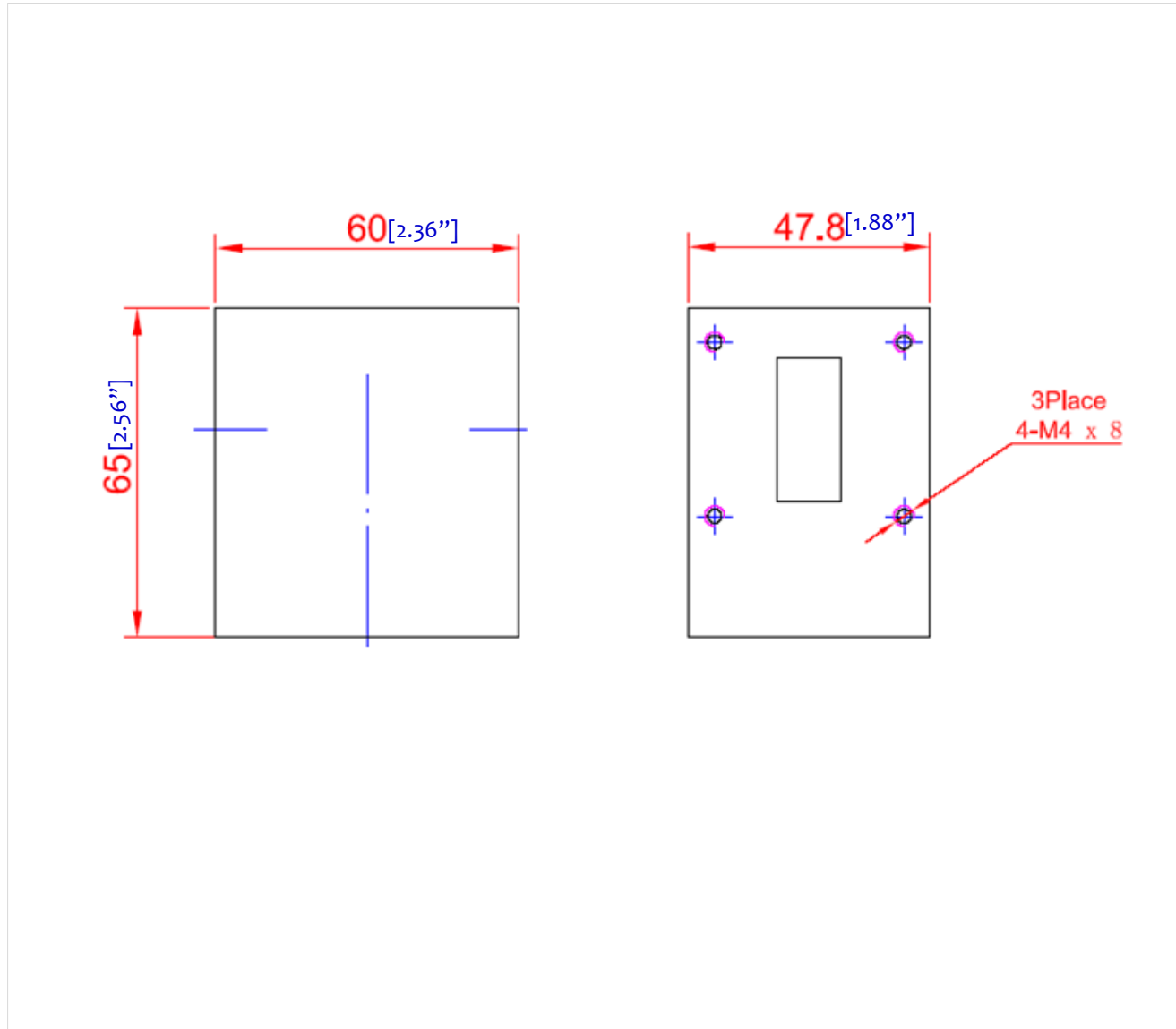

Important Notice

The information contained herein is believed to be reliable. RF-Lambda makes no warranties regarding the information contained herein. RF-Lambda assumes no responsibility or liability whatsoever for any of the information contained herein. RF-Lambda assumes no responsibility or liability whatsoever for the use of the information contained herein. The information contained herein is provided "AS IS, WHERE IS" and with all faults, and the entire risk associated with such information is entirely with the user. All information contained herein is subject to change without notice. Customers should obtain and verify the latest relevant information before placing orders for RF-Lambda products. The information contained herein or any use of such information does not grant, explicitly or implicitly, to any party any patent rights, licenses, or any other intellectual property rights, whether with regard to such information itself or anything described by such information.

RF-Lambda products are not warranted or authorized for use as critical components in medical, life-saving, or life sustaining applications, or other applications where a failure would reasonably be expected to cause severe personal injury or death.